

**EXAMINING STUDENTS' UNDERSTANDING OF ELECTRICAL
CIRCUITS THROUGH MULTIPLE-CHOICE TESTING AND INTERVIEWS**

by
PAULA VETTER ENGELHARDT

A thesis submitted to the Graduate Faculty of
North Carolina State University
in partial fulfillment of the
requirements for the Degree of
Doctor of Philosophy

PHYSICS

Raleigh

1997

APPROVED BY:

J. Richard Mowat

John S. Risley

Chair of Advisory Committee
Robert J. Beichner

Lynne E. Baker-Ward

Abstract

ENGELHARDT, PAULA VETTER. Examining Students' Understanding of Electrical Circuits through Multiple-choice Testing and Interviews. (Under the direction of Robert J. Beichner.)

Research has shown that both high school and university students have misconceptions about direct current resistive electric circuits. At present, there are no standard diagnostic examinations in electric circuits. Such an instrument would be useful in determining what conceptual problems students have either before or after instruction. The information provided by the exam can be used by classroom instructors to evaluate their instructional methods and the progress and conceptual problems of their students. It can be used to evaluate curricular packages and/or other supplemental materials for their effectiveness in overcoming students' conceptual difficulties.

Two versions of a diagnostic instrument known as Determining and Interpreting Resistive Electric Circuits Concepts Tests (DIRECT) were developed, each consisting of 29 questions. DIRECT was administered to groups of high school and university students in the United States, Canada and Germany. The students had completed their study of electrostatics and direct current electric circuits prior to taking the exam.

Individual interviews were conducted after the administration of version 1.0 to determine how students were interpreting the questions and to uncover their reasoning behind their selections. The analyses indicate that students, especially females, tend to hold multiple misconceptions, even after instruction. The idea that the battery is a constant source of current was used most often in answering the questions. Although students tend to use different misconceptions for each question presented, they do use misconceptions associated with the global objective of the question. Students' definitions of terms used on the exam and their misconceptions were examined. Students tended to confuse terms, especially current. They assigned the properties of current to voltage and/or resistance.

One of the major findings from the study was that students were able to translate easily from a “realistic” representation of a circuit to the corresponding schematic diagram. Results indicated that students do not have a clear understanding of the underlying mechanisms of electric circuit phenomena. Students had difficulty handling simultaneous changes of variable. Current was the main concept used in solving the problems. Some of the students who were interviewed reverted to formulas to answer the questions.

Dedication

I would like to dedicate this dissertation in memory of my father, Elmer Edward Vetter, Jr., who died on July 11, 1967. He never got to see his baby girl grow up. I miss him and wish he was here to witness this accomplishment. It is ironic that this project should involve electric circuits since it was an accident involving electricity that took his life. Daddy, I love you and this is for you.

Biography

I was born in Louisville, Kentucky with the name Paula Gail Vetter. I am the youngest of six girls. I went to Seneca High School where I graduated seventh in my class of 296. I graduated Magna Cum Laude from Eastern Kentucky University with a major in Physics and a minor in Mathematics in May of 1989.

My husband, Robert Thomas Engelhardt, was my laboratory instructor at Eastern. We moved to North Carolina where he attended Duke University. I attended North Carolina State University where I received my MS in Physics from NCSU in August of 1992. We gave birth to our first child, Robert Edward, in October of 1995. We are currently living in Greencastle, Pennsylvania.

From a very young age, I have been interested in teaching so it is no wonder that I am pursuing research with an educational emphasis. I had several opportunities to teach small sections of the class as early as eighth grade. I enjoy watching students make connections between what is spoken and what occurs in reality. I would like to pursue a teaching career at the community college or 4-year college level and to continue to do educational research as it interests me. I would also like to explore the cognitive aspects of students' knowledge acquisition.

Acknowledgements

I want to start by thanking my husband, Robert Thomas Engelhardt, and my son, Robert Edward, for their love and patience through this exhausting process. If it were not for their support and understanding and Little Robert's intoxicating laughter, I would not have been able to complete this project. My mother, Wilma R. Vetter, has always been a constant source of support and inspiration for me. I can call her anytime and she always cheers me up and gives me the incentive to continue.

I next want to thank my advisor, Robert J. Beichner, for his guidance and for sharing his expertise in this area. Lynne Baker-Ward is another committee member who deserves recognition. Her consultations on the interview data and some of the analyses were invaluable.

My greatest thanks goes to all the instructors and their students who participated in this study. If it were not for them, this project would not exist. I would also like to thank the individuals who served on my independent panels of experts. Their expertise and commitment to improving education were very helpful in revising and improving DIRECT.

Table of Contents

List of Tables	ix
List of Figures	xii
Chapter 1 Introduction.....	1
Chapter 2 Review of the Literature	6
2.1 Definition of misconception	7
2.2 Overview of chapter	8
2.3 Models of current flow	10
2.4 Battery as a constant current source.....	16
2.5 Three ways students reason about electrical circuits.....	18
2.5.1 Sequential reasoning	19
2.5.2 Local reasoning	20
2.5.3 Superposition reasoning.....	20
2.6 Variable uses of alternative conceptions	22
2.7 Areas of difficulty and explanations for some of them	25
2.7.1 Inability to apply formal concepts to electric circuits.....	25
2.7.1.1 Difficulties of a general nature	25
2.7.1.1.1 Failure to distinguish among related concepts	26
2.7.1.1.2 Lack of concrete experiences with real circuits	34
2.7.1.1.3 Failure to understand and apply the concept of a complete circuit.....	35
2.7.1.1.4 Inability to handle simultaneous change of variable	36
2.7.1.2 Difficulties with concepts related to electric current	36
2.7.1.3 Difficulties with concepts related to potential difference	37

2.7.1.4 Difficulties with concepts related to resistance	38
2.7.2 Inability to relate formal representations and numerical measurements to electric circuits.....	38
2.7.3 Inability to reason qualitatively about the behavior of electric circuits.....	40
2.7.3.1 Tendency to reason sequentially or locally, rather than holistically.....	40
2.7.3.2 Lack of a conceptual model for predicting and explaining the behavior of simple dc circuits.....	41
2.7.3.3 Inadequate use of and misuse of analogies	46
2.7.3.4 Fear of qualitative reasoning - mechanical use of formulas.....	48
2.7.4 Synopsis	49
2.8 Curriculum Approaches	49
2.8.1 Physics by Inquiry	50
2.8.2 Real-Time Physics.....	51
2.8.3 Constructivist/Cognitive Conflict/Conceptual Change Approaches.....	51
2.8.4 Microscopic/Macroscopic Approaches.....	54
2.9 Why diagnostic testing?.....	56
2.10 Diagnostic tests	57
2.10.1 Mechanics tests	57
2.10.2 Electric circuits tests	59
2.10.2.1 Research-oriented tests.....	59
2.10.2.2 Computerized tests	63
2.10.2.3 Assessment tests	64
2.11 How is DIRECT different?.....	64
Chapter 3 Methodology	67
3.1 Quantitative and Qualitative techniques	67
3.2 Sample	69

3.3 Development of DIRECT	71
3.3.1 Validity check 1 and Field test 0 - Open-ended version	74
3.3.2 Field Test 1 - DIRECT version 1.0.....	80
3.3.3 Validity Check 2 - Individual Interviews	82
3.3.4 Field Test 2 - DIRECT version 1.1 and Validity check 3.....	84
3.4 Summary.....	87
Chapter 4 Analysis of Data	88
4.1 DIRECT version 1.0	88
4.1.1 DIRECT version 1.0 Discrimination and Difficulty indices.....	88
4.1.2 DIRECT version 1.0 Objectives.....	96
4.1.3 DIRECT version 1.0 Groups of questions.....	97
4.1.4 DIRECT version 1.0 Group comparisons	103
4.2 Interview Analysis.....	104
4.2.1 Symbols used on DIRECT 1.0	104
4.2.2 Student definitions of terms.....	106
4.2.3 Analysis of student responses to the 10 selected questions.....	109
4.3 DIRECT version 1.1	128
4.3.1 DIRECT version 1.1 Discrimination and Difficulty Indices.....	128
4.3.2 DIRECT version 1.1 Objectives.....	135
4.3.3 DIRECT version 1.0 Groups of questions.....	136
4.3.4 DIRECT version 1.1 Group comparisons	139
4.3.5 DIRECT version 1.1 Pre/post-instruction data	141
4.4 Results from the Factor Analyses of versions 1.0 and 1.1	144
4.5 Comparison of DIRECT versions 1.0 and 1.1 and problems with each version	147
4.6 Summary.....	151

Chapter 5 Conclusions	153
5.1 Research Question 1	
Can a multiple-choice exam be used reliably to determine students' ideas about simple circuits?.....	153
5.2 Research Question 2	
What conceptual models are students using to answer the proposed problems?	154
5.3 Research Question 3	
How are individual differences in gender and in course level affecting the results?	156
5.4 Research Question 4	
Do the results reveal any unknown misconceptions or provide additional insights into possible explanations for the existing misconceptions?	157
5.5 Summary of major findings.....	158
5.6 Limitations of this study and its associated instruments.....	160
5.7 Implications and suggestions for further study	161
Bibliography	165
Appendix A Information obtained from the test sites.....	174
Appendix B High school and University Textbooks and Laboratory Manuals	184
Appendix C Open-ended version of DIRECT	187
Appendix D DIRECT version 1.0	198
Appendix E DIRECT version 1.1	210
Appendix F Instructions for the 1996 Independent Panel of Experts	222
Appendix G Graphical representation of the results from DIRECT versions 1.0 and 1.1	224
Appendix H Misconceptions found on versions 1.0 and 1.1	240

List of Tables

2.1 Emergent Knowledge Claims regarding Alternative Conceptions.....	9
2.2 Stage Related Description of the Schema	15
2.3 Percentage Use of Superposition reasoning by students in Venezuela.....	22
2.4 Variation of elementary and middle school teachers' knowledge.....	24
2.5 Percentage results for the Category questionnaire.....	28
2.6 Comparison of categories for pairs of concepts for Grade 10.....	28
2.7 Subjects' responses to propositions associated with voltage and current.....	30
2.8 Results of student knowledge of the term voltage.....	31
2.9 Percentages for question "What is electricity like?"	32
2.10 Percentage correct and errors for question, "Where is electricity?"	34
2.11 Images and results associated with various groups of students and professionals.....	46
2.12 Use of water analogy by 33 second year comprehensive school pupils in Britain.....	47
2.13 Percentage of case study students holding a particular model.....	53
2.14 Elements of understanding of simple circuits covered by the test	60
3.1 Sample 1 - Open-ended version.....	70
3.2 Sample 2 - DIRECT version 1.0.....	70
3.3 Sample 3 - DIRECT version 1.1.....	71
3.4 Objectives for DIRECT.....	72
3.5 List of independent panel of experts	75
3.6 Statistical results for DIRECT version 1.0.....	80
3.7 Statistical results for DIRECT version 1.1.....	85
4.1 Overall results for DIRECT version 1.0.....	89
4.2 University results for DIRECT version 1.0	90

4.3 High school results for DIRECT version 1.0.....	91
4.4 Student performance for each objective for DIRECT version 1.0	97
4.5 Students' ability to translate between three descriptions of circuits.....	100
4.6 <i>t</i> -test results for each sample taking DIRECT version 1.0	104
4.7 Results from interviews regarding symbols used on exam.....	105
4.8. Classifications used with student definitions of terms on DIRECT version 1.0.....	107
4.9 Comparison of students' definitions of current with the other terms.....	108
4.10 Comparison of students' definitions of energy and power.....	108
4.11 Comparison of students' definitions of potential difference and voltage	109
4.12 Classifications used to code student interviews and their frequencies	119
4.13 Summary of Interview Results.....	123
4.14 Misconceptions summary for each student and question	124
4.15 <i>t</i> -test results for each interview question regarding confidence level	126
4.16 Overall results for DIRECT version 1.1.....	130
4.17 University results for DIRECT version 1.1	131
4.18 High school results for DIRECT version 1.1.....	132
4.19 Student performance for each objective for DIRECT version 1.1	136
4.20 Correlation values for questions 3 and 7.....	138
4.21 <i>t</i> -test results for university students in Canada and the United States.....	140
4.22 <i>t</i> -test results for high school students in Canada, Germany and the United States	140
4.23 Pre/post-instruction data from NCSU (all 29 questions).....	142
4.24 Pre/post-instruction data from Seton Catholic High School	143
4.25 Paired <i>t</i> -test results for NCSU and Seton Catholic High School.....	144
4.26 Results from the factor analysis of version 1.0.....	145
4.27 Results from the factor analysis of version 1.1.....	146

A.1 Information from the 1995 test sites who used DIRECT version 1.0.....	175
A.2 Information from the 1996 test sites who used DIRECT version 1.1.....	178

List of Figures

2.1 Schematic representation of circuit	12
2.2 Schematic representation of a series circuit	13
2.3 Evolution of students' conceptions of current and energy across age	14
2.4 Comparison of a single bulb with two bulbs in series.....	16
2.5 Evolution of students' conceptions of the function of the battery across age	17
2.6 This circuit represents a series-parallel combination.....	18
2.7 This circuit represents a parallel-series combination.....	19
2.8 Question 11	20
2.9 Questions 21 and 22.....	21
2.10 Causal models of current in simple series and parallel circuits.....	23
2.11 Schematic representation of the junction	24
2.12 Short circuit.....	26
2.13 Student's representation of the GIVE-schema	30
2.14 Pictures presented to the students to answer the question, "Where is electricity?"	33
2.15 Circuit similar to one used by Johsua and van Aalst.....	36
2.16 Question 7	37
2.17 Circuits given in Cohen study.....	38
2.18 Carrier model associated with local/sequential thinking.....	41
2.19 Use of perspectives across tests by Improved and Unimproved Performers	44
2.20 Use of perspective shifts by Improved and Unimproved Performers	44
2.21 Circuits illustrating students' assumptions about contact points of battery	45
2.22 A simple electronic circuit using a voltage divider for the input stage	62
3.1 Question 29 of the open-ended version	76

3.2 Question 15 from DIRECT version 1.0.....	77
3.3 Question 15 from DIRECT version 1.1.....	77
3.4 Question 21 from open-ended version of DIRECT	79
3.5 Question 3 as it appeared on the open-ended version	79
3.6 Question 3 as it appeared on DIRECT version 1.0	79
3.7 Distribution of scores for DIRECT version 1.0 for the overall sample	82
3.8 Frequency distribution of scores for DIRECT version 1.1 for the overall sample	86
4.1 Question 26 from DIRECT version 1.0.....	92
4.2 Question 20 from DIRECT version 1.0.....	93
4.3 Question 28 from DIRECT version 1.0.....	93
4.4 Question 18 from DIRECT version 1.0.....	94
4.5 Question 13 from DIRECT version 1.0.....	95
4.6 Question 12 from DIRECT version 1.0.....	96
4.7 Question 10 from DIRECT version 1.0 with percentages.....	98
4.8 Question 29 from DIRECT version 1.0 with percentages.....	99
4.9 Battery symbol.....	105
4.10 Question 8 from DIRECT version 1.0.....	110
4.11 Question 3 from DIRECT version 1.0.....	110
4.12 Question 15 from DIRECT version 1.0.....	112
4.13 Question 16 from DIRECT version 1.0.....	114
4.14 Question 22 from DIRECT version 1.0.....	116
4.15 Question 23 from DIRECT version 1.0.....	117
4.16 Number of overall students providing correct reasoning at Interview	121
4.17 Number of university students providing correct reasoning at Interview.....	121
4.18 Number of high school students providing correct reasoning at Interview	122

4.19 Question 14 from DIRECT version 1.1	129
4.20 Question 27 from DIRECT version 1.1	129
4.21 Question 11 from DIRECT version 1.1	133
4.22 Question 13 from DIRECT version 1.1	134
4.23 Question 25 from DIRECT version 1.1	135
4.24 Question 3 from DIRECT version 1.1	137
4.25 Question 7 from DIRECT version 1.1	138
4.26 Frequency distribution for pre- and post-instructional data using DIRECT version 1.1 at North Carolina State University (NCSU)	142
4.27 Frequency distribution for pre- and post-instructional data using DIRECT version 1.1 at Seton Catholic High School	143

Chapter 1

Introduction

Between the idea
And the reality
Between the motion
And the act
Falls the Shadow.

T.S. Eliot

This quote by T.S. Eliot (Oxford Dictionary of Quotations, 1980, p. 203) epitomizes the focus of this research study. There are differences between what students and physicists believe happen in direct current (DC) resistive electrical circuits. Using typical classroom examinations, students may appear to understand a given phenomena very well. However, when given an examination that differs from the standard, their understanding appears to falter (Hestenes, Wells, & Swackhamer, 1992, p. 150; Arons, 1990, p. 170). Information needs to be available to the typical classroom instructor, both at the high school and university levels, that probes this gray area between what students believe and what they appear to understand on typical examinations regarding DC resistive electrical circuits.

A proven way to determine what students believe is to conduct individual interviews. This approach provides the most in-depth information and does so in a manner that the interviewee prefers, speaking. However, this approach requires both training and extensive amounts of time to conduct and analyze, neither of which the typical classroom instructor can afford. An alternative is to use multiple-choice testing. The format is familiar to most students. It is easily graded and can still provide information on how students think and what they understand. Unfortunately, it cannot probe as deeply as interviews can. Combining the two

approaches to benefit from the strengths of each while minimizing their weaknesses may be a better alternative. One can gain the depth of information one desires from the interviews and utilize the speed and objectivity of the multiple-choice exam. This combination is what has been implemented in this study.

The literature indicates that students have two main misconceptions regarding DC resistive electrical circuits: (a) Current is consumed and (b) the battery is a source of constant current. In analyzing circuits, students view it in a piece-meal fashion as opposed to globally. There is some evidence to indicate that students change their reasoning patterns to suit the question at hand. Thus, they do not appear to use a single, consistent model to analyze circuit phenomena.

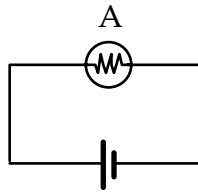

Figure 1.1: Simple electric circuit containing a bulb, battery and connecting wires

How do physicists view the typical electric circuit? Consider the simple circuit shown in Figure 1.1. It consists of a battery, a light bulb, and connecting wires. In analyzing circuits of this type, one typically assumes that the wires offer no appreciable resistance to the current. Current is the flow of charges. Historically, the charges were believed to be positive and this convention has remained in use to this day. The battery is considered ideal (it has no internal resistance) and is a source of constant potential difference. The light bulb is a type of resistor. Resistors impede the current in a manner that is similar to that of a constriction in a water pipe. The charges are set in motion by the electric field that is produced by the potential difference maintained by the battery. The battery sets up a gradient of charge around the circuit. This

gradient forms the electric field inside the wires; contrary to electrostatics where the electric field is always zero inside a conducting metal. This latter part of the description of circuit phenomena, which establishes the connection between electrostatics (electric fields, etc.) and electric circuits, is only now beginning to appear in textbooks (Chabay & Sherwood, 1995a; Cutnell & Johnson, 1995).

Physicists use schematic diagrams to represent the elements and their behavior in the circuit. Students' recognition of what these diagrams represent is an important aspect of their understanding of circuits. Research reveals that students view these diagrams as a system of pipes within which flows a fluid they refer to as electricity. Students have difficulty identifying series and parallel connections in the diagrams.

Although there are several tests available, they are limited in their design and applicability to a general audience. Thus, a diagnostic instrument which used standard test development procedures was produced. Students' alternative views of circuit phenomena were incorporated into the distracters. This instrument is appropriate for use with both high school and university students. It can be used as a diagnostic instrument to determine what misconceptions students hold or as an assessment instrument to evaluate new classroom teaching techniques or curricular materials.

Results from the two administrations of this instrument as well as follow-up interviews with a sub-sample of students who took version 1.0 provide the data necessary to answer the following research questions.

- 1) Can a multiple-choice exam be used reliably to determine students' ideas about simple circuits?
 - a) Is the exam statistically reliable?
 - b) Is the exam a valid measure of student concepts?

If question 1 can be answered affirmatively, we are naturally led to question 2.

- 2) What conceptual models are students using to answer the proposed problems?

- a) Are they using a single model to solve a variety of problems?
- b) Are they using different models to solve particular problems?

Again, if we can categorize the conceptual approaches students utilize when working with these circuits, then we could investigate how these approaches vary between students.

- 3) How are individual differences in gender and in course level affecting the results?
 - a) Are differences in the performance on the tests, in the number of misconceptions used, and in the confidence related to gender?
 - b) Are there differences related to course level in the performance on the tests, in the number of misconceptions used, and in the confidence?

And finally, because the qualitative portion of the study is similar to the approach used by other researchers in originally uncovering student misconceptions, we may be able to discover additional discrepancies between student and expert ideas about circuits.

- 4) Do the results reveal any unknown misconceptions or provide additional insights into possible explanations for the existing misconceptions?

Chapter 2 describes the literature associated with DC resistive electric circuits. The definition of the word misconception is discussed first along with an overview of the chapter. The literature review begins with a discussion of the current models and descriptions of the alternative reasoning patterns that students use. Other areas of difficulty that are ultimately assessed on DIRECT and explanations for their existence are presented next. Curriculum approaches that have been developed to help minimize student's misconceptions are addressed. An examination of various assessment instruments that have been produced by other researchers is discussed and reasons for the superiority of DIRECT are given.

Chapter 3 presents the methodology that has been implemented in this study. The chapter opens with a comparison of multiple-choice and interview techniques. The samples used are presented. A detailed discussion of the developmental process used to produce the

three versions of DIRECT and the various means for evaluating their reliability and validity are reported. Statistical results for each multiple-choice version are presented.

Chapter 4 lays the foundation for answering the research questions. It discusses the results from the two administrations of the multiple-choice versions of DIRECT. Results from interviews conducted with a sub-sample of students having taken DIRECT version 1.0 are presented. The factor analyses of the two versions are presented. A comparison of the two multiple-choice versions and problems associated with each are discussed.

Chapter 5 addresses the research questions and summarizes some of the main findings of the study. It notes the limitations of the instruments and the study, describes how these results impact the research and teaching community, and provides suggestions for further research.

Chapter 2

Review of the Literature

Investigations into students' understanding of direct current (DC) resistive electrical circuits led to the development of a set of models students use to explain current. Research indicates two prominent misconceptions: (a) Current is consumed within the circuit and (b) the battery is a constant current source. Students reason sequentially or locally in making predictions about circuits rather than considering the circuit as a whole. These findings apply not only to American students but to those in other countries as well. These misconceptions are very resistant to change with some even held by graduate students who have had years of additional instruction. A variety of new curriculum methods aimed at eliminating or challenging these misconceptions have been developed but have not been tested systematically for their effectiveness in changing student conceptions.

Instructors are sometimes unaware of the research base on student conceptual difficulties. Tests like the Force Concept Inventory (FCI) and the Test of Understanding Graphs in Kinematics (TUG-K) provide instructors with a connection to research findings by giving information about the conceptions students use to understand the world around them. These two tests are concerned with the area of mechanics. The Determining and Interpreting Resistive Electric Circuits Concepts Test (DIRECT) was developed to fill a similar role in the area of electricity and magnetism. Although other researchers have developed tests in this area, the tests were not developed in a rigorous and systematic manner and are limited in their applicability to a general audience. The remainder of this chapter will outline the work performed by others in the area of direct current electric circuits and describe how DIRECT fills the niche.

2.1 Definition of misconception

Many different terms have been used to describe students' views of the world, including phrases like naive conceptions, preconceptions, alternative conceptions, and misconceptions. Of these, misconception is the most often used. Some researchers and educators place a heavy negative connotation on the term. However, as David Hammer (1996) points out, all the terms have a core of similar ideas. Student conceptions:

- i) are strongly held, stable cognitive structures;
- ii) differ from expert conceptions;
- iii) affect in a fundamental sense how students understand natural phenomena and scientific explanations; and
- iv) must be overcome, avoided, or eliminated for students to achieve expert understanding. (p. 1318)

The term "misconception" with the above four properties will be used in the remainder of this paper.

The conceptions students hold deserve respect. They are not simply wild guesses. They arise from students' attempts to explain their everyday experiences and observations of the world around them. As Ault (1984) writes,

It's easy to dismiss misconceptions as a sign of sloppy thinking, an indication that the person who holds them has simply failed to understand the evidence. But if we examine the misconceptions of children, we often see imaginative and perceptive thinking. (p. 22)

To further emphasize the point, Dykstra, Boyle, and Monarch (1992) write,

they [the student conceptions] are rationally based on the students' experiences with the world and prove adequate for the person-on-the-street to accomplish most everyday tasks. Such conceptions cannot, therefore, simply be written off as wrong. (p. 621)

2.2 Overview of chapter

This project combines the use of interviews with a diagnostic instrument to explore students' understanding of DC resistive circuits. The specific benefits of this approach will be deferred to Chapter 3. However, using this combination maximizes the information that can be obtained. The last three sections of this chapter (2.9-11) will explore why there is a need for a diagnostic instrument and how DIRECT is different from other instruments that already exist.

The body of knowledge regarding students' understanding of DC electrical circuits is quite extensive. The literature can be broken down into themes which form the basis for the various sections of this chapter. Sections 2.3-5 will discuss students' conceptual models of electric circuits. Section 2.6 describes elementary and middle school teachers' conceptions of electric circuit phenomena. Section 2.7 summarizes other areas of difficulty that students have with electric circuits. Sections 2.3-7 illustrate the variety of difficulties that students have with electric circuits and the types of errors that one might expect to see in the results from the administration of DIRECT and from the interviews. The various instructional approaches that have been developed to promote conceptual change will be presented in Section 2.8. One of the uses for a diagnostic instrument like DIRECT would be to assess the effectiveness of these curriculum approaches in reducing the number of misconceptions that students have. As will be discussed in Chapter 4, some of the students who participated in the study were taught via some of these approaches.

These various sections address the emergent knowledge claims proposed by Wandersee, Mintzes, and Novak (1994). In examining the literature on alternative conceptions, they have outlined eight emergent knowledge claims based on the whole array of alternative conceptions research that exists (see Table 2.1). These claims can also be used to examine electric circuits conceptions in particular.

Table 2.1: Emergent Knowledge Claims regarding Alternative Conceptions (p. 195)

Claim 1	Learners come to formal science instruction with a diverse set of alternative conceptions concerning natural objects and events
Claim 2	The alternative conceptions that learners bring to formal science instruction cut across age, ability, gender, and cultural boundaries
Claim 3	Alternative conceptions are tenacious and resistant to extinction by conventional teaching strategies
Claim 4	Alternative conceptions often parallel explanations of natural phenomena offered by previous generations of scientists and philosophers
Claim 5	Alternative conceptions have their origins in a diverse set of personal experiences including direct observation and perception, peer culture and language, as well as in teachers' explanations and instructional materials
Claim 6	Teachers often subscribe to the same alternative conceptions as their students
Claim 7	Learners' prior knowledge interacts with knowledge presented in formal instruction, resulting in a diverse set of unintended learning outcomes
Claim 8	Instructional approaches that facilitate conceptual change can be effective classroom tools

Before moving on to the main review of the literature, it seems like an appropriate moment to examine claim 4 in Table 2.1. A recent article by Benseghir and Closset (1996) examines the educational difficulties students have with circuits from a historical viewpoint. When reasoning about new phenomena, scientists use knowledge that they have formed from

previous experiments as an initial starting point for understanding. In circuits, this initial knowledge comes from electrostatics. Concepts like attraction and repulsion of charges and discharging are used to explain the behavior of batteries connected to an element. Historically, the focus has been on the charges at the ends of the battery. The authors found a similar emphasis among high school and first and second year university students in Algeria and France. They suggest that this “makes the distinction between an open circuit and a closed circuit irrelevant and disguises the idea of complete circulation, especially inside generators” (p. 190). Thus, knowledge about electrostatics can interfere with the acquisition of the scientifically accepted view of the behavior of electric circuits.

2.3 Models of current flow

One of the simplest ways to begin a study of DC resistive electrical circuits is to try to light a light bulb given only the bulb, a battery, and a piece of wire. Evans (1978) reports that only about half of the high school seniors, university students, and university graduates to whom he has given this task knew how to solve it readily (p. 15).

Kärrqvist (1987) describes several attempts by 16 year old Ed to perform the above task. Ed tries several variations of the same form. He makes a connection from one terminal of the battery to the base of the light bulb. Both terminals of the battery are tried as well as different locations along the length of wire. This student viewed current as leaving the battery and being used up in the circuit elements, so that no current returns to the battery. This particular solution is known as the monopolar (Arnold & Millar, 1987), *unipolar* (Osborne, 1981), or sink model (Fredette & Lochhead, 1980). This model has been found in students ages 8-14 years old in several countries, including the United States (Osborne, 1983), New Zealand (Osborne, 1981), Southeast Asia (Russell, 1980), and the United Kingdom (Arnold & Millar, 1987). The unipolar model is a first attempt at understanding how to light the bulb and is generally replaced by another model.

A second model, which is used by students ages 8-17 (Osborne, 1983; Shipstone, 1984a), is the *clashing currents* model. Shipstone (1984a) found that this model decreased in use with increasing age so that less than 10% use this model by age 17. In this paradigm, current leaves both terminals of the battery and is used up by the circuit element. Arnold and Millar (1987) in their study of children ages 11-12 found two versions of this model. The first regards the clash of opposing currents as the cause for the light (p. 556). The second describes the superposition of two currents (each current is considered sufficient, itself, to light the bulb) as the cause for the light (p. 556).

Osborne (1983) discusses a *less current in return path* model in which current leaves one terminal of the battery, is partly "used up" by the bulb, with the remainder returning to the other terminal of the battery. Osborne used circuits containing a battery, a single bulb, and connecting wires during interviews with students ages 8-12. Shipstone (1984a) extended this work to older students ages 12-17 and to more complex circuits such as those containing either fixed or variable resistors and those connected in either series or parallel configurations (p. 185). Shipstone distinguished two versions of this less current in return path model. In version one, current is unidirectional and becomes weaker as it goes so that elements further along in the circuit receive less current. In version two, current is unidirectional but not conserved and is shared equally between circuit elements (p. 187). This particular model seems to remain consistent in its use across ages (p. 188).

Gauld (1988) found that 10 of the 14 students, age 14, who were interviewed adopted a carrier model. He describes their thinking as follows: "Electricity was transported by carriers from the battery to the bulbs where it was used up. The empty carriers returned to the battery to be loaded up again" (p. 269). These students used this model concurrently with one of the previously discussed models. Use of the carrier model may be explained if students had been introduced to the train analogy. The train cars are like the charges in the wires. The train cars are moved by a constant force (the engine, for example). Obstacles on the tracks are akin to

resistance. When the cars are full, they have energy. When the cars are empty, they have no energy. The energy is re-supplied by the battery, or the engine in this case.

These models have a similar theme. Current is consumed as one traverses the circuit. They differ from the *scientific view* which regards current as unidirectional and conserved. Shipstone (1984a) found that there is an increase in the use of the scientific model with age (p. 188). Students' non-scientific view of current is probably due to confusion between energy and current.

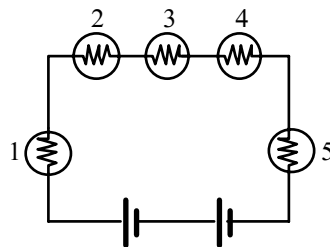

Figure 2.1: Schematic representation of circuit (Gott, 1984b, p. 65)

But how prevalent is this view of current? Given the circuit shown in Figure 2.1, the Assessment of Performance Unit found that 26% of the students ages 14-16 in the sample predicted that bulbs 1-5 become progressively dimmer (Gott, 1984b, p. 65). McDermott and van Zee (1984) interviewed 23 students who had previously studied electricity and 9 prospective and practicing teachers and found that one third predicted the bulb A would be brighter than bulb B in the circuit shown in Figure 2.2 (p. 40). Shipstone, von Rhöneck, Jung, Kärrqvist, Dupin, Johsua, and Licht (1988) in a study performed with students ages 15-17 in England, France, the Netherlands, Sweden, and West Germany found that current consumption was a viable idea in all these samples even after instruction (p. 305). Dupin and Johsua (1987) gave a written test to students ages 12-22 and found that current consumption was used even after years of instruction. (see Figure 2.3) Heller and Finley (1992) found that 10 of the 13

elementary and middle school teachers used a sequential model which has a proposition that current is used up by the bulb (p. 264). Licht and Thijs (1990) found in the Netherlands that 61% of the students ages 13-14 used the idea of current consumption while only nine percent of the students ages 15-18 did. They also found that 40% of the girls and only 26% of the boys used the idea of consumption (p. 411). Interviews with students enrolled in introductory physics courses in Brazil (Buchweitz & Moreira, 1987) and South Africa (Helm & Jiya, 1993) also indicate the use of the current consumption idea. It is evident that this misconception is widespread across age, instruction, and culture. Furthermore, it appears to be highly resistance to instruction.

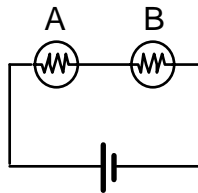

Figure 2.2: Schematic representation of a series circuit

One possible explanation as to why instruction has little impact comes from a study which re-analyzed Shipstone's current model data and Shayer and Adey's Piagetian stage data. Monk (1990) found that there was "a good qualitative and quantitative fit between the sequencing of the models and the proportions of pupils expressing those views at any age" (p. 137). He proposed the stage related description of the schema shown in Table 2.2. This relation between current model and Piagetian stage may explain why so many students have difficulty with circuits concepts. This, however, does not indicate that students should not be taught circuits. Given that not all students will be operating at the formal operational level, instructors' expectations of students' understanding may need to be more reserved.

Figure 2.3: Evolution of students' conceptions of current and energy across age
B indicates before instruction and A indicates after instruction (Dupin & Johsua, 1987, p.
797)

Table 2.2: Stage Related Description of the Schema (pp. 137 & 139)

Model based on Osborne	Schema	Operational Epistemology	Piagetian Stage
Uni-polar	Explanations for the working of electrical circuits are only in terms of the need to connect apparatus to electrical supply	Centres [<i>sic</i>] on the instrumental and figurative of making a connection between [<i>sic</i>] the source and consumer	Pre-operational (1)
Clashing currents	Explanations of current flow are in terms of positive and negative currents flowing in opposing directions from the poles of the battery	Mental processing of the circuit through the continued use of the instrumental and figurative but with the added commutative relationship of flow of 'something' from each of the two poles of the battery	Early concrete (2A)
Attenuation	Explanations of magnitude of current flow at a point in the circuit are in terms of functions of individual circuit elements taken one at a time around the circuit	Repeated single mental transformation with just two variables: dependent and in-dependent $(I \propto \frac{1}{R})$	Late concrete (2B)
Sharing	Explanations of magnitude of current flow at a point in the circuit are in terms of the similarity and difference of circuit elements [<i>sic</i>], and therefore of their operation taken simultaneously	Mental transformation of related variables with multiple elements only where complexity is reduced by the similarity of elements (e.m.f. = I (R1+R2 ...) if R1 = R2 ...)	Late concrete early formal transition (2B-3)
Scientific	Explanations of current flow at a point in a circuit in terms of total operation of all circuit elements simultaneously	Mental transformation of multi-variate nature (e.m.f. = I (R1+R2 ...))	Formal operation (3)

2.4 Battery as a constant current source

The second main misconception students have regarding DC electrical circuits is the belief that the battery is a constant current source. Students believe that the battery supplies the same amount of current to every circuit regardless of the number and/or arrangement of the circuit elements. For example, in the circuits shown in Figure 2.4, both bulbs A and B would be predicted to be equally bright. The brightness of bulb C would depend on whether students believed that current was consumed or not.

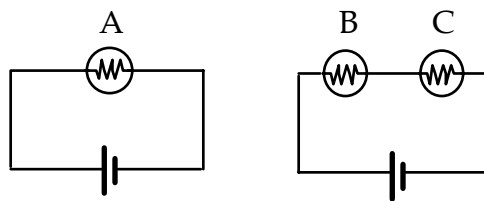

Figure 2.4: Comparison of a single bulb with two bulbs in series

This misconception is also resistant to change and is found across different age ranges and cultures. Licht and Thijs (1990) found that students in both age groups, ages 13-14 and 15-18, use this conception about 40% and 44%, respectively. Boys and girls were found to use this conception equally about 42% of the time (p. 411). Two separate studies, one performed in Italy (Picciarelli, DiGennaro, Stella, & Conte, 1991b, p. 61) and the other in Israel (Cohen, Eylon, & Ganiel, 1983, p. 409), found that one third of the students reasoned in this manner. Figure 2.5 shows that 40-50% of the students in France use this conception through high school with 30% continuing to hold the view in their first two years of university (Dupin & Johsua, 1987, p. 798). Heller and Finley (1992) found that 13 of the 14 elementary and middle school teachers used this concept (p. 264). This concept has also been found in Brazilian (Buchweitz & Moreira, 1987) and Italian (Danusso & Dupré, 1987) students and students in five European

Figure 2.5: Evolution of students' conceptions of the function of the battery across age
B indicates before instruction and A indicates after instruction (Dupin & Johsua, 1987, p.
798)

(Shipstone et al., 1988) countries: England, France, the Netherlands, Sweden, and West Germany.

2.5 Three ways students reason about electrical circuits

Aside from the two major misconceptions students have about circuits, they also reason in three ways that differ from scientific reasoning, sequentially, locally, and by superposition. Sequential reasoning results in a “before and after” examination of the circuit. Students using sequential reasoning believe that (a) current travels around the circuit and is influenced by each element as it is encountered and (b) a change made at a particular point does not affect the current until it reaches that point (Closset, 1984b; Shipstone, 1984a). Thus, for the circuit shown in Figure 2.6, closing the switch will not affect bulb A since the current has already passed that point. von Rhöneck and Grob (1987) differentiate local from sequential reasoning in the following way: “local reasoning means that the current divides into two equal parts at every junction regardless of what is happening elsewhere” (p. 564). Given the circuit shown in Figure 2.7, students would say that the current in branch 1 was equal to that in branch 2. If students are using a superposition reasoning, they conclude that if one battery makes a bulb shine, then two batteries, regardless of the configuration, will make the bulb shine twice as bright (Sebastià, 1993).

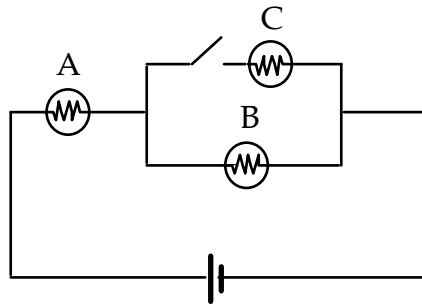

Figure 2.6: This circuit represents a series-parallel combination

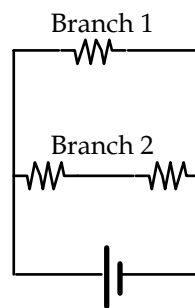

Figure 2.7: This circuit represents a parallel-series combination

.c3.2.5.1 Sequential reasoning

Picciarelli, DiGennaro, Stella, & Conte (1991a) report a study using sophomore science and engineering oriented students in Italy. One hundred seventy-three of these students were interviewed before instruction on electricity and 23.5% were found to use sequential reasoning. Seventy-four of the initial 173 students were present at the post-test phase and 33.5% were found to have approaches dominated by sequential reasoning, even after instruction. Sequential reasoning was used by 14% of an additional sample of 63 third year students in physics and engineering who had already studied and passed an examination of electricity (p. 46).

Although there is no distinction made between sequential and local reasoning, Licht and Thijs (1990) show a similar trend in their data using students ages 13-18 in the Netherlands. Students ages 13-14 use sequential reasoning 22% while students ages 15-18 use it 24%. They also found that girls reasoned in this manner more often than boys (30% for girls and 18% for boys) (p. 411).

Sequential reasoning was used by a group of students ages 12-17 and by a group of physics and engineering graduates training to be physics teachers (Shipstone, 1984b, p. 78). Studies also report the use of this reasoning by both university and high school students in Rome (Danusso & Dupré, 1987) and elementary and middle school teachers here in the United States (Heller & Finley, 1992).

2.5.2 Local reasoning

In their study of students ages 15-17 in England, France, the Netherlands, Sweden and West Germany, Shipstone et al. (1988) found that on question 11 (see Figure 2.8) the majority of the students used this form of reasoning. Local reasoning has also been found with a group of students age 15 in the UK (Millar & King, 1993) and first year university students in South Africa (Helm & Jiya, 1993).

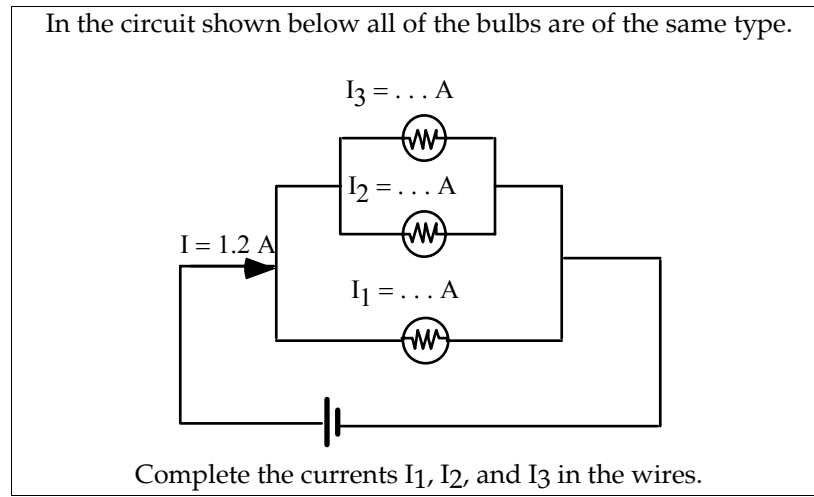
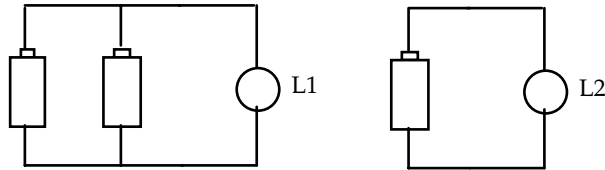

Figure 2.8: Question 11 (Shipstone et al., 1988, p. 310)

2.5.3 Superposition reasoning

Only one reference associated with electrical circuits and this form of reasoning was found. Sebastià (1993) examined the use of this form of reasoning and sequential reasoning in a group of 273 university students in Venezuela. The students were at various stages in their learning of electric circuits. Students in LE1 (First year - physics 1) and LE2 (Second year - physics 3) had not yet studied electricity while those in LE3 (Second year - electric networks 1) and LE4 (Third year - electric networks 4) had. A test containing 15 questions adapted from other researchers was given. Results on the questions associated with sequential reasoning showed a decline in use with year similar to those already discussed in 2.5.1. The two questions associated with superposition reasoning are shown in Figure 2.9. The results are shown in Table 2.3 (Sebastià, 1993).

Q21. In the following circuits, batteries and bulbs are identical. With respect to the bulbs' shine we can say that: A) L1 shines more than L2; B) L2 shines equal to L1; C) L2 shines less than L1.



Q22. In the following circuits, batteries and bulbs are identical. With respect to the bulbs' shine we can say that: A) All shine equally; B) Only L1 and L2 shine equally; C) Only L1 and L3 shine equally; D) L2 and L3 shine less than L1.

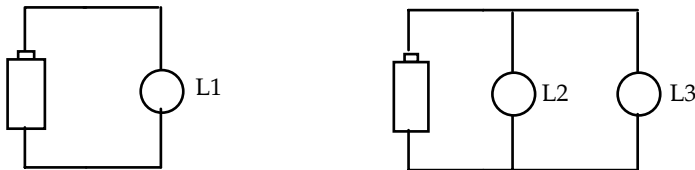

Figure 2.9: Questions 21 and 22 (Sebastià, 1993)

Table 2.3: Percentage Use of Superposition reasoning by students in Venezuela

Level	Correct Answer Question 21	Correct Answer Question 22	Alternative Answer Question 21	Alternative Answer Question 22
LE1	46.8	38.3	46.8	55.5
LE2	52.4	42.9	46.0	52.4
LE3	60.9	37.3	32.7	55.4
LE4	90.6	39.6	7.5	54.7

As can be seen from Table 2.3, there is a decline in use of the superposition reasoning with level for question 21 but a consistent use of it in question 22. Sebastià suggests that the students answer some questions using declarative knowledge as in Q21 and answer others using particular reasoning patterns as in Q22.

2.6 Variable uses of alternative conceptions

Heller and Finley (1992) investigated the hard core and protective belt beliefs of a group of elementary and middle school teachers. “Hard core ideas are those ideas that learners persist in believing, even when evidence contradicting these ideas is available. . . . Protective belt of ideas are the ideas that learners readily change to defend the hard core” (p. 259). The causal models are presented in Figure 2.10. The variations in their knowledge are shown in Table 2.4.

The researchers defined the following five propositions as the hard core ideas.

1. Current is the flow of energy.
2. The battery is the source of the current.
3. The circuit is initially empty of the “stuff” that flows through the conductors.
4. The battery releases the same, fixed amount of current to every circuit.
5. Bulbs use up current. (p. 268)

The protective belt ideas either changed or were contradictory. The teachers either changed one of the propositions in the sequential model or made a temporary switch to the static model to explain some of the phenomena presented. They also used two contradictory propositions about the time dependent nature of current. The time dependent proposition states that “the (fixed) current flows out of the battery and does not diminish until it reaches a bulb that ‘uses up’ some of the current” (p. 269). The time independent proposition states “when there is more than one bulb in a circuit path, each bulb uses up some of the (fixed) current, so *all* bulbs receive less current” (p. 269). The researchers found that the teachers were missing some conditional knowledge on when and how to apply their propositions. Thus,

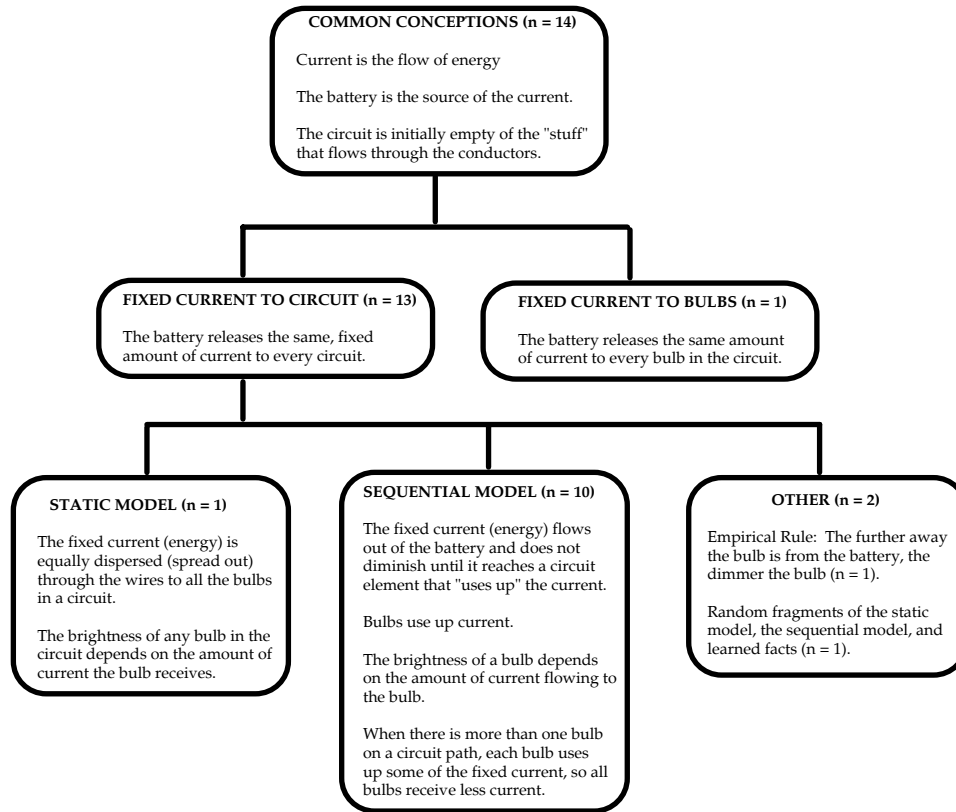

Figure 2.10: Causal models of current in simple series and parallel circuits (Heller & Finley, 1992, p. 264)

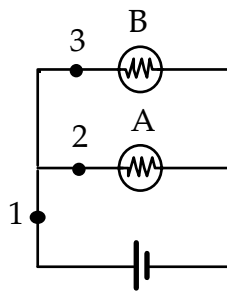

Figure 2.11: Schematic representation of the junction (p. 267)

Table 2.4: Variation of elementary and middle school teachers' knowledge (pp. 265-8)
 Number in parentheses indicates the number of teachers holding that idea (N=13)

Direction of Current	Effect of wires on current	What happens when current encounters a junction (see Figure 2.11)
Conventional current (7)	Wires conduct current to the bulb (6)	$1=2=3$ because current has not yet encountered resistance
Electron current (2)	Wires use up current (4)	$2>3>1$ based on distance to negative terminal of battery
Current flows from both battery terminals (1)		$1=2$ because current has not passed through bulb yet. Least in 3 because current has passed through both A and B
		$1=2$ because it has not yet reached A. Least at 3 because current flows through circuit with A first then through circuit with B
		$1=3>2$ because less current flows down the path to bulb A
		$(1=2+3)>2>3$ because at point 1 current has not split and at point 2 more current flows through closer path
		$(1=2+3)>(2=3)$ because current divides evenly at junction
		$(1=2+3)>(2=3)$ because point 1 is the sum of 2 and 3. Equal resistance in path. Current takes path of least resistance.

different problem types and different contextual and perceptual features of the problems cued different propositions (p. 273).

2.7 Areas of difficulty and explanations for some of them

In the previous sections, the focus has been on the misconceptions and erroneous reasoning patterns students use in answering questions about DC electric circuits. This section explores other areas of difficulty students experience in their study of circuits that might be reflected in the analysis of the data from the administration of DIRECT and individual interviews. McDermott and Shaffer (1992) have outlined additional student difficulties derived from years of research into students' understanding of electric circuit phenomena. This outline will form the organization of this section. Additional research from other sources will be included to expand and elaborate on their outline and to supply explanations for some of these difficulties.

2.7.1 Inability to apply formal concepts to electric circuits

Students' conceptions and scientifically accepted conceptions are often in conflict. These conflicts can be broken down into four subsections, difficulties of a general nature, difficulties with the concept of current, difficulties with the concept of potential difference, and difficulties with the concept of resistance with some of these aspects already having been presented in this chapter.

2.7.1.1 Difficulties of a general nature

Students have some general problems with electric circuits that are not explicitly concept oriented. They have trouble distinguishing between key concepts like current and energy. They have not had as much practical experience with electric circuits as they have had with topics like gravity. They do not consistently apply the concept of complete circuit. For example, they will state that the circuit shown in Figure 2.12 will light the bulb even though

this is a short circuit. They have trouble manipulating more than one variable at a time. When solving a problem, students assume if an element is in the circuit, it must serve some purpose.

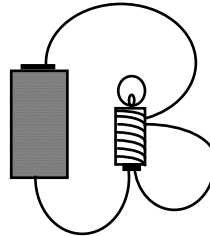

Figure 2.12: Short circuit

2.7.1.1.1 Failure to distinguish among related concepts

Students use terms like electricity, current, voltage, potential difference, energy, and power interchangeably. They have a difficult time defining these terms and using them correctly. Researchers have shown that students especially confuse current with energy and current with voltage. Possible explanations include language usage, early definitions of matter and energy, and the order of introduction in the curriculum.

McDermott and van Zee (1984) interviewed 23 students who had completed their study of electric circuits in the standard introductory physics course and 9 prospective and practicing teachers. One third of the students predicted that bulb A would be brighter than bulb B. (Refer to Figure 2.2) When asked to explain their reasoning, students referred to “‘something’ that they believed was being used up by the ‘first’ bulb in the circuit - current, energy, power, potential difference, or voltage” (p. 41). Gott (1984b) found that 50% of students ages 14 - 16 gave responses that something (power, energy, electricity) was used up or shared (p. 69).

Gott (1984b) notes that our models may be artifacts produced by imposing our meaning for the terms on their [the students] lack of any such precision (p. 71). This sentiment

is echoed by Shipstone (1984b) in discussing students' use of the word "electricity" and the researcher's assumption that the students meant "current" (p. 73).

In addition to students' general confusion between terms, there are two specific cases that need to be mentioned. Students equate current and energy (Tiberghien, 1984, pp. 112-3; von Rhöneck & Völker, 1984, p. 96). This may be the reason why students believe that current is consumed within the circuit. As the electrons move within the circuit, they lose energy. Students also associate current and voltage (Métoui, Brassard, Levasseur, & Lavoie, 1996, p. 206; Shipstone, 1984a, p. 195; Tiberghien, 1984, pp. 117-9; von Rhöneck & Völker, 1984, p. 97). They believe both current and voltage flow through the circuit and that current is the cause of the voltage, not vice versa (Shipstone, 1984a, pp. 194-5). Using association tests with 12 year old students, Duit (1984b) found that they associated current (Strom in German means stream) 35% of the time with the word energy (p. 209). In the same study, students associated voltage with current 22% of the time (p. 212).

von Rhöneck and Völker (1984) report that, prior to instruction, students attribute three properties to current: (a) The current can be stored in the battery and/or the wires, (b) current is consumed, and (c) current is energy (p. 96). Heller and Finley (1992) found that "regardless of their initial definitions, however, *all* of the teachers [elementary and middle school] treated current as energy when they were asked to predict or compare the brightness of bulbs" (p. 263).

Jung (1984) used a category questionnaire with two groups of students, Grades 8 and 10. Students were asked to categorize current, voltage, charge, energy, and electron into one of three classifications, event, substance, or property. The results are presented in Table 2.5, and the numbers in bold indicate the highest percentage of students classifying that term with that property. The given Chi-squared values are between Grades 8 and 10.

Table 2.5: Percentage results for the Category questionnaire for Grade 8 (N=70) and Grade 10 (N=73) (pp. 198-9)

Grade	Current		Voltage		Charge		Energy		Electron
	8	10	8	10	8	10	8	10	10
Event (Things that occur)	30	25	49	21	30	18	30	21	0
Substance (Things that endure)	50	68	26	32	14	22	30	38	95
Property (Things that recur)	20	7	19	40	9	51	37	37	4
Chi-squared	p < 0.05		p < 0.001		p < 0.001		no difference		

Table 2.6: Comparison of categories for pairs of concepts for Grade 10 (pp. 178 & 180)

Comparison	Event	Substance	Property	Chi-squared
Charge vs. Electron		Electron	Charge	
Current vs. Energy		Current Energy	Energy	p < 0.001
Current vs. Voltage		Current	Voltage	p < 0.001
Current vs. Charge		Current	Charge	p < 0.001
Voltage vs. Energy		Energy	Voltage Energy	No significant difference

Table 2.6 uses the results for the Grade 10 students from Table 2.5 to compare how students categorized term pairs. For example, students in Grade 10 classified an electron 95% of the time as a substance. Note that no term had a dominant categorization of event. It is worth noting that students distinguished charge and electron since an electron is merely an example of a charge. Looking at this categorization, it seems reasonable that students would confuse current and energy since they have categorized both current and energy as a substance.

The confusion between current and voltage also makes some sense from this categorization in that current is a substance and voltage a property. Students view voltage as a property of current.

Current is used by students as the primary concept with voltage serving as a secondary concept in solving circuits problems (Cohen, Eylon, & Ganiel, 1983, p. 407; von Rhöneck and Völker, 1984, p. 97). Students relate voltage and current. Voltage is seen as the force or strength of the current (Maichle, 1981, p. 180; von Rhöneck and Völker, 1984, p. 97). "The emphasis on current rather than pd [potential difference] methods was salient in the way students dealt with the various questions" (Cohen, Eylon, & Ganiel, 1983, p. 411). Shipstone et al. (1988) report that voltage is not differentiated from current. Students treat voltage as having closely similar properties to current (p 307). Shipstone (1984a) reports evidence that children learn about voltage in terms of what they understand, rightly or wrongly, about current flow (p. 195). "In fact, in 31% of the explanations in which there was reference to voltage, this was treated as something which flows" (p 195).

Maichle (1981) performed a study to examine students use of a TRANSFER-schema in association with the concepts of current and voltage. This schema can take one of two forms, either as a GIVE-schema or a TAKE-schema. In the GIVE-schema, the battery gives something to the bulb, which is the recipient. In the TAKE-schema, the bulb takes what current it needs to make the bulb light. The schema can be illustrated as in Figure 2.13.

Maichle used four groups of subjects as shown in Table 2.7. Each group was asked to answer yes or no to a collection of propositions. Only those that deal with current and voltage will be presented here. Table 2.7 presents the results of these propositions. The results supported the hypothesis that voltage is part or property of the current and the two must always occur together (p 179).

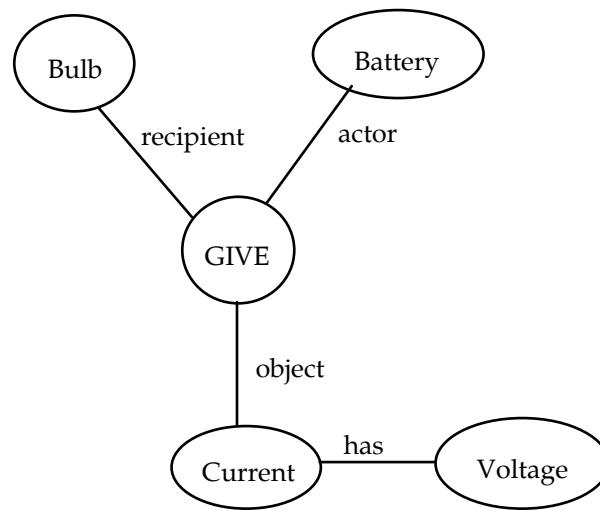

Figure 2.13: Student's representation of the GIVE-schema (p. 176)

Table 2.7: Subjects' responses to propositions associated with voltage and current (pp. 178 & 180)

	Group 1 N=300 Realschule Grade 8 (ages 13-15)		Group 2 N=100 Gymnasium Grade 8 (ages 13-15)		Group 3 N=36 University level students in 4th or 5th semester		Group 4 N=10 Physicists or experienced teachers	
	yes	no	yes	no	yes	no	yes	no
Voltage can occur independently of the occurrence of current	23	63	30	69	94	6	100	0
Voltage is the intensity or force of the current	40	49	24	69	6	94	0	100
Voltage is part of the current	70	22	77	22	11	89	0	100
Voltage and current are the same thing	23	64	8	84	3	97	0	100

In a study of students ages 13-14 and 14-15 in Greece, the students were asked about their knowledge of the term “volt” in pre-instructional interviews. The results are presented in Table 2.8 and show that students seem to associate voltage with some aspect of current (how much there is, measurement unit, or force/strength).

Table 2.8: Results of student knowledge of the term voltage
(Psillos, Koumaras, & Tiberghien, 1988, p. 31)

	Ages 13-14	Ages 14-15
Had heard term volt	66 of the 90	44 of the 57
Associated volt with batteries	35 of the 66	30 of the 44
Voltage indicated how much current (or energy or electricity) exists within battery	26% (N=66)	27% (N=44)
Voltage indicated unit of measurement of (or it measures) current or electricity	21% (N=66)	18% (N=44)
Voltage indicates force (or strength or power) of current (or electricity)	17% (N=66)	27% (N=44)

From the studies presented, it is clear that students confuse terms. But why do they do so? One explanation already presented suggests that it is the instructor’s or researcher’s assumptions about the meaning behind the terms students use. Another is how they categorize terms. These two explanations both have a language component. Three other explanations are the students’ life-world knowledge, early instruction on matter and energy and finally, the order of instruction.

Duit (1984b) outlines three ways that everyday language can induce learning difficulties. First, language provides notions since electricity does not directly effect our senses. Language provides a logical structure. Duit points out the subject-predicate-object structure of Indo-European languages. This along with the verb “to be” allows the idea of existence to be conferred on objects and events. Concept names are used in everyday language.

Solomon, Black, Oldham, and Stuart (1985) performed a study in England with 11-12 year old students who had not yet studied electricity and 13-14 year old students who had one electricity unit. They examined the students' life-world knowledge, associated folklore, and emotional overtones. The results for the 13-14 age group will be presented in parentheses. When students were asked "what is electricity," they associated it 50 (49)% of the time with use and 33 (17)% of the time with danger (p. 286). Table 2.9 presents the results for the question "what is electricity like?" Students were given five similes from which to choose. The authors note a "frequent lack of ability to understand and use an operational simile" (p. 290).

Table 2.9: Percentages for question "What is electricity like?" (p. 289)

	ages 11-12	ages 13-14
Like a fire	52	66
Like a river	51	71
Like a river because it flows or moves	44	66
Like a dangerous animal	85	88
Like a fuel	72	76
Like a lot of tiny particles	35	38

To answer the third question, "where is electricity?," students were presented with four pictures and asked to circle the place where they thought electricity was. The four pictures are presented in Figure 2.14. A large number of the students circled the lightning (p. 290). There was a tendency to circle connectors rather than carriers or stores of electricity. Additional results are presented in Table 2.10.

Figure 2.14: Pictures presented to the students to answer the question, "Where is electricity?" (Solomon, Black, Oldham, & Stuart, 1985, p. 291)

Table 2.10: Percentage correct and errors for question, "Where is electricity?" (pp. 290-2)

	ages 11-12	ages 13-14	Errors
Torch	47	45	Less than half circled both battery and bulb and it was common to circle only bulb
Pylon	35	30	Circled either whole structure or insulators which carry cables
Lamp	49	60	Number drew circle around disconnected plug of lamp

Bauman and Adams (1990) give a possible explanation as to why students confuse electricity and energy. They examined elementary school texts and found a persistent lesson taught about the difference between matter and energy. Matter is defined as anything that takes up space and has mass. Energy is everything else. Electricity has no mass and does not take up space; thus, it must be energy.

Cohen, Eylon and Ganiel (1983) found that students emphasize current rather than pd (potential difference). They suggest one reason is that most have studied circuits in some form as young children. Common to all forms is the emphasis on current, which is more concrete and intuitive than pd. The lack of emphasis on pd as the cause for current is another reason. The order of concept introduction is a factor. Current is generally introduced first so current may remain the central concept in students' minds (p. 411).

2.7.1.1.2 Lack of concrete experiences with real circuits

Students do not have much practical experience with the inner workings of simple circuits. At home, students flip a switch with little thought as to why this simple action causes the light to shine. McDermott and Shaffer report that 60% of the students lacked previous experience with simple circuits and only 15% indicated some familiarity with batteries and

bulbs (p. 996). Three separate studies (Arnold & Millar, 1987, p. 555; Gott, 1984a, p. 60; Shipstone, 1984b, p. 76) have shown that students do not understand that the screw fitting of the bulb is also a contact point. Andre and Ding (1991) suggest that functional fixedness may be influencing the student's perceptions (p. 311). Functional fixedness is "a tendency to use the objects and concepts in the problem environment in only their customary and usual way" (Ashcraft, 1989, p. 592).

2.7.1.1.3 Failure to understand and apply the concept of a complete circuit

Students do not understand and correctly apply the concept of a complete circuit. Gott (1984a) reports that more than 90% of the students age 15 in the study recognized the need for a completed circuit (p. 56). However, there was an insignificant group of students who were satisfied by any complete circuit, including a short circuit (p. 56). Fredette and Lochhead (1980) report that many students enter college without a clear understanding of the passing-through process which is essential for understanding the concept of a complete circuit (p. 198). Tiberghien (1984) notes that elementary and secondary school level pupils still believe that one connection from battery to bulb is sufficient to have the bulb shine (pp. 111, 113). Fredette and Clement (1981) report that a significant number of students fail to recognize a short circuit either physically present or in diagram form (p. 280). They suggest several reasons why the students' failed to recognize the short. They are as follows:

1. One student commented that "wires 'don't really do anything'" (p. 283). This student used the knowledge that the wires have no resistance and thus were only minor participants in many of the problems he had encountered.
2. Students try to match patterns of similar problems.
3. Once the translation has been made from the physical objects to the diagram, the physical objects are no longer considered.
4. Students use a schema for a series or parallel circuit which they use to assimilate the given configuration.
5. The theoretical principles learned in the classroom do not provide information on how and when to apply them. (pp. 284-5)

van Aalst (1984, p. 124) and Johsua (1984, p. 275) suggest that, in circuits like the one shown in Figure 2.15, students apply functional reasoning before causal reasoning. The resistor

is there; thus, it must serve some purpose. An additional explanation as to why some students do not always correctly identify a circuit as complete was presented in the discussion section 2.7.1.1.2. When the circuit has light bulbs as elements, they do not recognize that the bulb has two contact points.

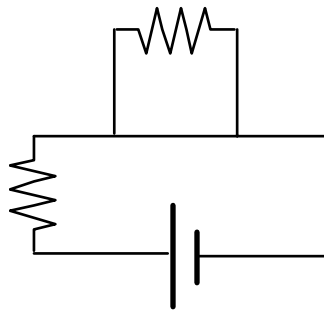

Figure 2.15: Circuit similar to one used by Johsua and van Aalst

2.7.1.1.4 Inability to handle simultaneous change of variable

Cohen, Eylon, and Ganiel as well as van Aalst report that students have difficulty when required to deal with functions of more than one variable. Ohm's law is a simple equation of the form $V = IR$. However, it can become quite challenging when one makes a change in both the number of batteries and the number and arrangement of the resistors within a circuit. Many more factors must be assessed in order to arrive at the correct solution.

2.7.1.2 Difficulties with concepts related to electric current

Many of these difficulties have already been discussed in section 2.3 and 2.4. To recap, students believe that direction of current and order of elements matter, that current is "used up" in a circuit, and that the battery is a constant current source (McDermott & Shaffer, 1992, pp. 996-7).

Shipstone (1984b) reports that there is a decline in the use of the clashing currents model and that this dramatic decline is due to instruction on the unidirectional view (p. 75). A

possible explanation for students' use of the clashing currents model is that instructors often talk about two types of current, conventional and electron. With conventional current, protons are supposed to move from positive to negative. This is an old idea that has been retained from the days before we knew that it was the electrons that actually did the moving. Thus, electron current is the motion of electrons around the circuit from negative to positive. Therefore, there are two types of motion as well as particles in motion. Andre and Ding (1991) found that students who held the clashing currents model did better on wiring tasks because their model requires two connections from the battery (p. 312).

2.7.1.3 Difficulties with concepts related to potential difference

Students fail to recognize that an ideal battery maintains a constant potential difference between its terminals, to distinguish between branches connected in parallel across a battery and connected in parallel elsewhere, and to distinguish between potential and potential difference (McDermott & Shaffer, 1992, pp. 997-8). Additionally, Cohen, Eylon, and Ganiel report that students have difficulty with the concept of internal resistance of the battery. On the question shown in Figure 2.16, one third of the students chose c or d, which is equivalent to ignoring the internal resistance (p. 411).

<p>In the circuit drawn in the figure [to the right], the ammeter has no resistance, and the battery has an e.m.f. ϵ and an internal resistance r. Which of the following is correct?</p> <ol style="list-style-type: none"> The current flowing through the ammeter is zero. The p.d. across the ammeter is zero. The potential drop <u>inside</u> the battery is zero. The energy dissipated in the whole circuit is zero. 	
---	---

Figure 2.16: Question 7 (Cohen, Eylon & Ganiel, 1983, p. 410)

2.7.1.4 Difficulties with concepts related to resistance

When students encounter questions dealing with resistance, there is a tendency to focus on the number of elements or branches. They fail to distinguish between equivalent resistance of a network and the resistance of an individual element. They have difficulty identifying series and parallel connections (McDermott & Shaffer, 1992, pp. 998-9). Finally, resistance is equated with consumption, not a hindrance (Cohen, Eylon & Ganiel, 1983, p. 411; Johnstone & Mughol, 1978; von Rhöneck & Völker, 1984, p. 97).

2.7.2 Inability to relate formal representations and numerical measurements to electric circuits

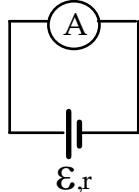
Students fail to recognize that a circuit diagram represents only electrical elements and connections, not physical or spatial relationships and fail to treat meters as circuit elements and to recognize the implications for their construction and external connections (McDermott & Shaffer, 1992, pp. 999-1000). Several studies have investigated students' understanding of circuit diagrams. These will be discussed shortly. A group of pupils ages 14-15 in Greece believed that the ammeter when connected in a circuit would consume current so that it functioned in the same manner as the light bulb. They did not understand that the ammeter simply allows current to flow through it and has a negligible effect on the circuit (Psillos, Koumaras, & Valassiades, 1987, p. 193).

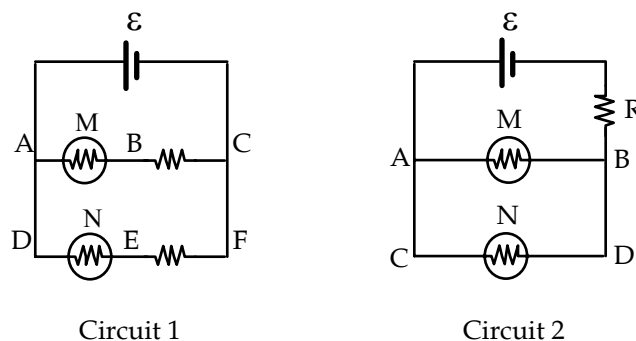

Figure 2.17: Circuits given in Cohen study (pp. 108 and 109)

Cohen (1984) found that all the students gave the same responses to two questions that appeared similar to the students but were actually quite different. The difference between Circuit 1 and Circuit 2 shown in Figure 2.17 is a change in the circuit arrangement. This change was unclear to the students (pp. 108-9). Feher (1983) argues "that the lack of recognition of a rotated circuit was due to a preconception on the part of the student about what does and does not matter in establishing equivalencies" (p. 332). She suggests that it may be due to poor spatial visualization and problems with actual manipulation of whole configurations (p. 332). Duit (1984a) found that 10 and 12 year old students judged the functioning of a circuit based on symmetry (p. 88). He also found that there was an apparent gain in the representation of the topological structure with instruction but that it was less than what was indicated on written tests (p. 92). Johsua (1984) reports a similar topological effect. He notes that students interpret diagrams as "figurative representations of a 'system of pipes' through which the passage of current (as a fluid) can take place" (p. 275).

Caillot (1984) performed a study of 10 undergraduates who had previously been taught circuits in high school but were not currently taking any circuits courses. Students were given three tasks: (a) Given 24 circuit diagrams on cards, describe them as series, parallel, or combinations of series and parallel, (b) given 24 circuit diagrams on cards, sort them into categories containing similar circuits, and (c) perform numerical calculations for the given circuits. The circuits presented on the 24 cards were of four types: series, parallel, series-parallel, or parallel-series. (See Figures 2.6 and 2.7 for the distinction between series-parallel and parallel-series.) The topology of the circuit diagrams was conserved. Results indicate that graphic representations of the same circuit were considered different by novices. The novices based their description on the surface features of the circuits, such as all lined up resistors are in series (even if a node exists between them) and all geometrically parallel resistors are in parallel (even if a battery is included in one of the parallel branches) (p. 142). On the sorting task, only 3 of the 10 succeeded on the whole sorting. When the students performed well, they looked at

the component configuration and the nodes. When they failed, they were unable to find useful criterion and made use of surface features (geometrical characteristics of the diagram such as external shape, generator position, existence of a small loop, and resistor configuration). The advanced novices were beginning to use physics principles in sorting the diagrams but were still constrained by geometrical considerations (p. 143).

2.7.3 Inability to reason qualitatively about the behavior of electric circuits

When asked to reason qualitatively, students tend to approach the circuit problems step by step as opposed to considering the circuit as a whole. There is evidence that students do not apply a consistent model. Instructors introduce analogies in an attempt to aid students' understanding of the material. There is conflicting evidence as to the effectiveness of this approach. Students have a fear of qualitative reasoning which may be due in part to lack of experience. Many of the problems students are asked to solve for homework or on examinations involve numerical calculations. Thus, when confronted with a qualitative question, they begin by writing down equations and trying to substitute.

2.7.3.1 Tendency to reason sequentially or locally, rather than holistically

In section 2.7.1.1.1, Duit's explanation of the affects of language on students' reasoning was discussed. He notes that the structure of Indo-European languages produces a tendency to think in the "thing" category and supports thinking in sequences of single cause-event elements (pp. 206-7). This may be one reason why students are drawn to sequential thinking.

Shipstone (1984b) has found an association between sequential reasoning and the use of the attenuation model for current and that sequential reasoning was developed independently of the other models (p. 81). Instructors could be unwittingly reinforcing the sequential model by their explanations of current flow in the classroom (Härtel, 1984, p. 346).

It is very common to verbally describe what is happening in the circuit shown in Figure 2.11, this way:

Considering conventional current, current leaves the battery from the positive terminal. At the left junction, part flows through bulb A and the remainder through bulb B. It recombines at right junction and returns to the negative terminal of the battery. The path would be reversed for electron current.

Härtel presents a model used in a US curriculum “Probing the Natural World” (shown in Figure 2.18) that may support local or sequential thinking. The empty carrier, upon passing the motor, cannot be affected by anything behind it (p. 346).

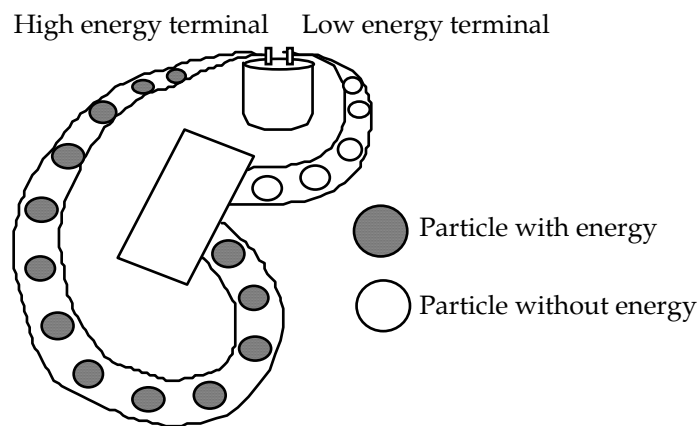

Figure 2.18: Carrier model associated with local/sequential thinking

2.7.3.2 Lack of a conceptual model for predicting and explaining the behavior of simple dc circuits

McDermott and Shaffer report

that most [of the students] had not synthesized the basic electrical concepts into a coherent framework. Lack-ing [sic] a conceptual model that they would use as a basis for predicting the relative brightness of the five bulbs in Fig. 2 [labeled as Figure 2.1], the students resorted to formulas, relied on intuition, or attempted to do both. (p. 1001)

Other studies indicate that students do have models that they use to predict the brightness of bulbs but they use them inconsistently. McDermott and Shaffer may be referring to these student models as intuition. Gott (1984b) notes that "floating voters" lack understanding of the underlying concepts and fall back on everyday terms to explain circuit phenomena (p. 70). He also notes the stability of the model used when applied to different questions depends on the familiarity of the circuit (p. 70). "A circuit picture more or less similar to a prototype will affect the novice's answers to the description and categorization tasks" (Caillot, 1984, p. 150).

Andre and Ding (1991) examined how students' declarative knowledge, changes in stimulus conditions, and students' current models affected performance on wiring tasks and a diagram test. Eighty undergraduates participating in the study were given 5 of 6 different wiring tasks with the goal of lighting a light bulb or sounding a buzzer along with a diagram test which consisted of 14 circuit diagrams. The wiring tasks varied both in the materials given to the student (battery in holder with two wires, lamp in holder with two wires, battery, bulb and a wire, etc.) and in the order in which they were presented. On the diagram test, students were asked which circuits would work and to explain their reasoning. Students were also given a science history questionnaire.

The researchers found that performance on the wiring tasks varied with the stimulus conditions and current model (based on Shipstone) students held. For example, students given one wire, a battery and a lamp or a lamp in holder had a more difficult time connecting the circuit because there was less support provided by the materials than those given a battery in a holder with two wires and a lamp in a holder. The order of presentation of the wiring tasks showed that if the tasks ranged from easiest to hardest, performance improved. Students receiving the difficult task last and holding models 1, 3 and 4 (clashing current, shared, or scientific) outperformed those holding models 0 and 2 (sink or lessening current). They found that the more experience students had, the more advanced their current model and the better their performance on the wiring tasks and diagram test. Students who did well on the wiring

tasks needed to know two pieces of declarative knowledge: (a) There are two terminals on both the bulb and the battery and (b) a direct, non-wire connection between the battery and bulb is possible (p. 311).

Research begun by White, Frederiksen and Spoehr (to be published) investigating the effects of “a computer environment that provides linked models that represent circuit behavior from different perspectives (such as a microscopic versus a macroscopic perspective) and at differing levels of abstraction.” This research has been extended by Gutwill, Frederiksen and Ranney (1996) who propose that students who reason from multiple perspectives will show improved understanding of the voltage concept. Additionally, they “hypothesize that high school students who construct an effective understanding of simple circuits will exhibit coherent shifts among perspectives in order to explain or understand a phenomenon” (p. 145).

Gutwill, Frederiksen and Ranney selected two groups of students who were divided into Control and Experimental groups. The Control group was tested before and after a unit on energy and waves. The Experimental group, as part of their coverage of electricity, were taught two perspectives, particle and aggregate. Assessment involved 17 problems, 16 multiple-choice with explanation of answer selection required and one design task, presented during clinical interviews. Interviews were conducted prior to and after instruction. The Experimental group scores increased while the Control group scores remained the same (p. 152). The Experimental group was further divided into Improved and Unimproved based on scores from pre/post interviews. Figure 2.19 shows the use of perspectives across tests for Improved/Unimproved performers (p. 154). The increases in use of the particle and circuit topology perspectives are a result of instruction (p. 154). The decrease in use of the aggregate perspective by the Unimproved performers is consistent with confusion between current and energy. Figure 2.20 shows the results of the two groups based on test and perspective shifts (p.

155). Both groups increase in use of coherent shifts but the Unimproved group also increases in the use of non-coherent shifts.

Figure 2.19: Use of perspectives across tests by Improved and Unimproved Performers (p. 154)

Figure 2.20: Use of perspective shifts by Improved and Unimproved Performers (p. 155)

Shipstone (1984b) noted that students' choice of current model depended on the assumptions that they made about the functions of the items presented in the problems (p. 74). Consider the two circuits shown in Figure 2.21. If a student believed only the top of the battery mattered, then he would say circuit 1 would light but circuit 2 would not (p. 74).

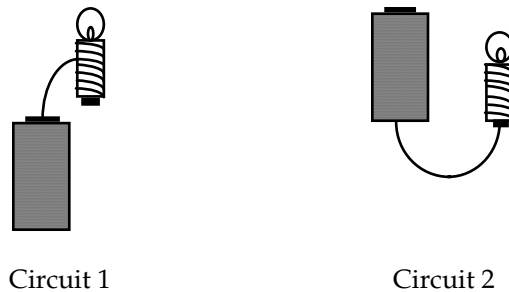

Figure 2.21: Circuits illustrating students' assumptions about contact points of battery

Arnold and Millar (1987) note that

Difficulties in grasping the abstract concepts of electricity often seem to stem directly from children's failure to "visualize" what is going on, or to construct a set of images to assist them in understanding and predicting. (p. 554)

Images used by various groups of students and professionals were examined by Stocklmayer and Treagust (1996). Their results are presented in Table 2.11.

Table 2.11: Images and results associated with various groups of students and professionals (Stockmayer & Treagust, 1996)

Group	Images/Results
High school students	Analogies such as water, billiard balls, and gravitation
Technical college students	Apprentice electricians richer pool of analogies than other trades but both showed signs of confusion and lack of confidence
University radiography students	Few meaningful images. Mostly pictorial using conventional symbols. Testing revealed a Shipstone Model 2 (Attenuation) or 3 (Sharing)
High school and University teachers	Billiard balls similar to HS
Lecturers in engineering and physics and practicing electricians and electrical engineers	Concerned with circuit as a whole. Images fundamentally field-like rather than atom-like.

Eylon and Ganiel (1990) suggest that students' problems with electricity may be due to a lack of understanding of the micro-macro links (p. 92), the links between electrostatics and electrokinetics phenomena (electric circuit phenomena). Students do not apply their knowledge of electric fields which is an electrostatics concept to electric circuits. It is this field that starts the charges moving. Potential is another electrostatics concept that is not translated to electrokinetics phenomena. This may result in the student not being able to visualize the circuit as a system and to grasp the functional relationships between its parts (p. 79).

2.7.3.3 Inadequate use of and misuse of analogies

van Aalst (1984) suggests that there is an inadequate use of analogies. He notes a study performed by Genter and Genter that showed students who used the teeming crowd analogy seemed to better understand series and parallel circuits than students who used the traditional water analogy (p. 122). He notes, however, that one must be careful when using and introducing analogies since students selectively use and sometimes use more than one analogy at a time to solve problems (p. 122).

The use of analogies needs to be considered carefully. For example, Osborne (1983) introduced a blood analogy to a group of students in the United States ages 9-12. After its introduction, some students were found to use the analogy as evidence to support their misconceptions (p. 80). "Some 20% of the students neither required an explanation of the analogy nor were they interested in relating it to reality" (p. 80)

Shipstone (1985) presents the results from a study of the use of the water analogy with 33 second year comprehensive school pupils in Britain. The results are shown in Table 2.12. The most striking result is that although more than half of the pupils saw the similarity, only 6% were able to use the analogy correctly. This result indicates that analogies should be used with care and consideration given to the benefits and disadvantages of using them.

Table 2.12: Use of water analogy by 33 second year comprehensive school pupils in Britain (p. 47)

Pupil response	Percentage
The pupil sees and notes the similarity between the flow of water and of electricity	54
The pupil claims that these similarities aid his understanding of the electrical case	33
The pupil actually appears to use the analogy when faced with a problem situation	27
The pupil uses the analogy correctly	6

Johsua and Dupin (1984) investigated students' understanding of circuit diagrams and found that students viewed the diagrams as real piping, inside of which flows a fluid, electricity (p. 133). Via this metaphor, they note links to both errors in current reasoning and to sequential reasoning. They contend that this metaphor is "too rich" (pp. 133 & 135)

In a separate study, the authors investigated the viability of resorting to analogies in teaching. They present a table of results from previous studies using the water model (1989, p. 209). This table indicates mostly null or neutral results with one positive result that appears to be anecdotal. Dupin and Johsua (1989) proposed the use of two analogies, the train analogy and heat conduction. Students ages 12, 14, and 16 were tested before and 1 month after instruction. Experimental classes were given a questionnaire and interviewed while the control classes were only given the questionnaire. The test results indicate that the two groups were similar prior to instruction but after instruction the experimental group did perform better (p. 220). "This result stands out clearly from the limited results of experimentation with the water analogy" (p. 222). No single analogy was found to improve student understanding (p. 222).

2.7.3.4 Fear of qualitative reasoning - mechanical use of formulas

When confronted with qualitative problems, students show a fear of reasoning qualitatively and resort to technical or quantitative approaches (Cohen, Eylon & Ganiel, 1983, pp. 411-2; Millar & Beh, 1993, pp. 358-60; van Aalst, 1984, p. 124). This is said to be due to a lack of experience solving qualitative problems (van Aalst, 1984, p. 124; Arons, 1990, p. 170).

In solving qualitative problems associated with electrical circuits, students often begin by writing down Ohm's law ($V = IR$). In doing so, they frequently make mistakes by not correctly utilizing the constraints (Cohen, Eylon & Ganiel, 1983, p. 409; McDermott & Shaffer, 1992, pp. 1001-2). Additional insights into students' understanding of Ohm's law have been investigated by Métioui et al. (1996). They performed a qualitative study of mainly electrical engineering students ages 17-20 in Quebec, Canada to examine their understanding of Ohm's law. Results indicate that the students view all circuits as linear and static. They will replace any resistor, even an unknown resistor, by "its equivalent resistance" (p. 193). The value of the unknown resistor is obtained from Ohm's law.

2.7.4 Synopsis

This concludes the main portion of the literature review. As this review has shown, students make a variety of mistakes and hold views that are not in agreement with science. The proposed explanations for some of these difficulties have been included to establish the basis for them. If DIRECT has been well constructed, it should reveal many of these difficulties. The interviews can provide replication of the explanations for these difficulties and have the potential for providing further insights. The next section provides a review of some of the approaches that have been developed to promote conceptual change. Included are any available assessments of their effectiveness in promoting conceptual change. The typical comparison is with traditionally taught courses. This section is relevant given that some of the students who participated in this study were taught using a few of these approaches. Additionally, these approaches suggest a use for DIRECT--impartial evaluation of the various curricular materials associated with DC electric circuits.

2.8 Curriculum Approaches

Over the last twenty or so years, educators have been trying to develop new curricular materials to address some of the conceptual problems associated with various physics topics. Some of the approaches that will be discussed in this section cover more material than just direct current resistive electric circuits. There is a common theme; students are actively engaged in the learning process and concepts are developed through the activities students perform in the classroom or laboratory. Students' prior conceptions are often addressed and challenged within the context of the materials. There is a definite constructivist feel to many of the approaches. Good and Brophy (1994) define constructivism as follows:

Students develop new knowledge through a process of active construction. They do not merely passively receive or copy input from teachers or textbooks. Instead, they actively mediate it by trying to make sense of it and relate it to what they already know (or think they know) about the topic. (p. 414)

The different approaches will be explained and any available evidence of their effectiveness discussed.

2.8.1 Physics by Inquiry

Physics by Inquiry is a set of instructional modules covering a few physics topics in great depth. The modules are laboratory based and involve active participation by the learner. Emphasis is put on developing scientific reasoning through the use of the scientific method. The modules were influenced by Arnold Arons' book, *The Various Languages* (1977), with initial activities discussed in an article by James Evans (1978). This curriculum is designed for use with preservice teachers and underprepared students entering college. It has been adapted and used with other populations as well (Shaffer & McDermott, 1992, p. 1003). The curriculum has been evolving since 1982. Changes have been based on results from individual demonstration interviews conducted by a number of graduate students associated with the Physics Education Group at the University of Washington, Seattle.

Evidence regarding the effectiveness of this approach over the traditional approach, which consists of lecture, laboratory, and perhaps recitation, is somewhat sketchy. Shaffer and McDermott (1992) write

It is difficult in a laboratory-based course to make a totally objective determination of the effectiveness of in-structional [*sic*] materials. However, there is some hard evi-dence [*sic*] that our curriculum on electric circuits is more suc-cessful [*sic*] than the traditional approach. Although many of our students have had considerably less preparation than those in the standard courses, their performance on quali-tative [*sic*] questions has been consistently better. (p. 1011)

Additional evidence to support this claim is provided by Thacker, Kim, Trefz, and Lea (1994) who conducted a study involving four groups of students. The groups were elementary education majors using the *Physics by Inquiry* materials, an Honors physics class, a standard calculus-based engineering class and an introductory course for non-science majors. Students in these classes were compared on four questions: two qualitative or synthesis questions and

two quantitative or analysis questions. Results indicated that the elementary education majors did significantly better ($p < 0.01$) on the synthesis problem than all the other classes (p. 631). The Honors class did significantly better on the analysis problems. The elementary education majors did somewhat better on the analysis problems than either the non-science majors or the calculus-based engineering class. Comparisons of the elementary education majors and the non-science majors showed that those using *Physics by Inquiry* did far better than the non-science majors. Thus, the inquiry method may be superior to traditional methods for the non-science majors.

2.8.2 Real-Time Physics

Real-Time Physics is an interactive activity-based introductory laboratory program. The activities rely heavily on the use of computer tools like voltage probes, motion detectors, and force probes for data collection and analysis. The materials are adapted from *Tools for Scientific Thinking* and *Workshop Physics* and are based on research outcomes. Evidence about the effectiveness of this portion of the curriculum indicates improved learning and retention for students who used the microcomputer-based laboratory materials (Sokoloff, 1994).

2.8.3 Constructivist /Cognitive Conflict/Conceptual Change Approaches

Kärrqvist (1984) has made use of constructivist teaching approaches and explains that when students are given the chance and are told what is expected from them, they can be very active, and can formulate and try to solve their own problems (p. 225). She provides interview and observational evidence from four pupils ages 14-16 (Kärrqvist, 1987).

Arnold and Millar (1987) discuss results from using a constructivist approach with students ages 11-12. Based on the results of initial interviews with students, a teaching sequence was developed that includes the following topics: bipolarity and the rule of circuit closure, circulation model of current, some differentiation of electrical energy and electric current, and the relationship of current and resistance (p. 559). There were six seventy minute practical lessons. Evaluation consisted of a second set of interviews performed one week after

the end of the sixth lesson. Compared to the initial interviews, improvements were made in many of the areas except the differentiation of electrical energy and electric current where students still performed poorly (pp. 560-1).

Cognitive conflict is based on the idea that if you put students into situations where their ideas are in conflict with experimental results or logic, students will adjust their ideas toward a more scientific viewpoint. Closset (1984a, p. 270) along with Arnold and Millar (1987, p. 558) report that cognitive conflict alone does not produce a change in students' conceptions. Arnold and Millar found that it may produce suppression or misinterpretation of evidence to fit existing theories (p. 558). Closset (1984a) points out that we need to verbally address students' ideas associated with presented problems. He describes an approach whereby students are presented with a question and told to answer it and explain their reasoning. The instructor then tells the students their typical answer and reasoning. He then criticizes this reasoning. The same problem is presented later and the same process followed. Each time more and more students arrive at the correct solution and reasoning. Closset notes that this process takes several weeks but says that nearly all the student eventually give the correct answer and reasoning (p. 270). It is not clear whether it is the repetition of information that causes the improved performance or if there is indeed a true change in students' underlying conceptions.

It has already been mentioned that students tend to confuse related terms like current and energy or voltage and current. In an effort to help promote conceptual change, a technique that uses concept substitution has been proposed by Diane Grayson. Students tend to believe that current is consumed within the circuit. However, it is the energy that is consumed. Using this technique, students retain their intuitive idea that something is consumed but the appropriate term is substituted for the erroneous one. In this case, energy would be substituted for current. Similarly, students believe that the battery is a source of constant current. Again, students retain the idea that the battery supplies a fixed amount of something while the

erroneous term current is substituted for the correct term voltage. In responding to questions relating to current consumption, prior to the introduction of the appropriate term, nearly 30% of the students believed current was consumed. This value dropped to 18% 20 days after the initial lesson (pp. 103 & 106). In responding to questions relating to the battery as a source of constant current, prior to instruction, 20% of the students believed this but after instruction, this value dropped to approximately 12% (pp. 103 & 106). In addition to students' apparent improved performance, this method probably also develops an improved sense of confidence, in that the student was not entirely erroneous in their thinking but only had the terms confused.

Cosgrove, Osborne and Carr (1984) describe a three phase conceptual change approach. The three phases are familiarization, challenge, and application. Fifteen children age 11 served as the case study group who used this three phase approach. Their performance was compared to a representative sample who used traditional methods. Students were tested after the familiarization and challenge phases and again one year later. Students were evaluated based on what current model (based on Osborne) they held at each testing. The results are presented in Table 2.13.

Table 2.13: Percentage of case study students holding a particular model (p. 252)

	Monopolar	Clashing currents	Less current in return path	Scientific
Before critical lesson (after familiarization phase)	0	7	86	7
After critical lesson (after challenge phase)	0	0	14	86
One year later	0	13	40	47

Results indicate that the familiarization phase alone does not produce a change toward the scientific view, but the challenge phase does. The change, however, is not long-term given that after one year, students' models are split between the scientific and the less current in return path model.

Carlsen and Andre (1992) were interested in the effectiveness of a computer simulation and use of a conceptual change text. They hypothesized that the combination of the two would produce better scores on the posttest. Eighty-three psychology students with no prior physics background were divided into six treatment groups. Treatment groups varied by text (traditional or conceptual change) and use of the computer simulation (before text reading, after text reading or no simulation). There were three one hour sessions over the course of three successive days. On the third day, the posttest consisting of 66 multiple-choice items with 26 conceptual questions on series circuits was given (p. 107). Students were classified into one of Shipstone's models via the posttest. Results indicate better performance on the posttest and model's score for those using the conceptual change text and improved model's score for those who used the simulation. Contrary to the main hypothesis, it was found that the simulation was effective whether used prior to or in combination with the text (p. 109).

2.8.4 Microscopic/Macroscopic Approaches

Eylon and Ganiel (1990) have investigated students understanding of the microscopic aspects of electric circuits. They have found that students lack the connection between the microscopic aspects (individual charges move due to electric field) and the macroscopic aspects (group motion of charges which is expressed as the current) (p. 86). They suggest that to have an adequate understanding of circuit phenomena, students need to comprehend three aspects: quantitative relationships those involving equations, functional relationships which involve qualitative considerations and correct descriptions of the interplay between circuit variables, and processes involving macro-micro relationships, where the macroscopic circuit parameters are tied with microscopic models and rules (p. 79).

To this end, approaches which emphasize voltage as the primary concept have been proposed at all levels of instruction from middle school through university (Cohen, 1984; Licht, 1991; Psillos, Koumaras, Valassiades, 1987; Psillos, Koumaras, Tiberghien, 1988; von Rhöneck, 1984). As previously cited, students believe that the current is responsible for the voltage.

Two of the various approaches that have been developed relating to voltage as primary concept will be discussed. One uses capacitors to view the inner workings of the circuit behavior. The other emphasizes a unified approach to electrostatics and circuits.

The Capacitor-Aided System for Teaching and Learning Electricity (CASTLE) project involves a battery-centered causal model (Steinberg & Wainwright, 1993). It is designed for high school students. Students use capacitors to observe transient bulb lighting and compasses to monitor activity in the wires (p. 353). The curriculum has been evaluated via a multiple-choice test constructed independent of the curriculum by David Brown. Three groups of students were selected. The experimental group consisted of students of the authors of CASTLE. The Dissemination group consisted of students whose instructors were supported by an author of CASTLE and who had attended a 2 hour training session. The Comparison group students used traditional methods rather than the CASTLE materials. There were large gains for both the Experimental and Dissemination groups with negligible gains for the Comparison groups. There were also gains in the confidence exhibited by females. Another important finding is that the curriculum can be disseminated without loss of effectiveness (p. 356).

Chabay and Sherwood (1995) have developed a curriculum that emphasizes a uniform approach that revolves around the field concept and attempts to unify electrostatics and circuits. There is an emphasis on using a small set of fundamental principles to explain a broad range of phenomena, qualitative reasoning, and matter at the atomic level. Students observe and analyze real phenomena via “desktop” experiments. “The textbook is interactive: there are empty boxes where the student is asked to give an explanation, complete a derivation, or record an experimental measurement” (Chabay & Sherwood, 1995b, p. 5) Thus, it is impossible

to simply sit down and read the text and gain a useful understanding of the concepts presented. The student is forced to become an active participant in the learning process. This curriculum is new and no rigorous evaluation has yet been made.

2.9 Why diagnostic testing?

After such an extensive review of the literature, it is appropriate to ask what more can possibility be contributed and why develop a diagnostic test. One benefit to developing a diagnostic instrument is for use in the classroom. The knowledge that is gained by the educational researcher does not always impact the typical classroom teacher or professor (Harmon, 1993; Treagust, 1988) who has little time to delve this deeply into electric circuit phenomena. David Hammer (1996) suggests that information about students' knowledge and understanding should come from a variety of sources including diagnostic test instruments (p. 1323).

But what benefit will a diagnostic test provide? Licht and Thijs (1990) explain:

The availability of a diagnostic instrument enables the teacher to identify groups of pupils within one class, each group having the same general preconceptions in a subject. This opens the possibility of remedial teaching focusing on particular types of preconception. (p. 414)

In this way multiple-choice tests can help teachers to trace persistent and coherent preconceptions among their pupils. Our experience shows that especially for beginning teachers and teachers who do not believe their pupils to have preconceptions, a multiple-choice test, being a familiar instrument, can serve as an eye-opener. (p. 415)

In addition to providing information on students' conceptions, tests can be used to evaluate curriculum and new approaches to teaching.

Multiple-choice tests provide a fast, objective way to determine students' grasp of some topic. It can be given to a large sample of students at the same time. However, the information that is gained is restrict by the material covered on the exam. The addition of individual student interviews allows one to further probe students' answer choices. The limitation here is

time and training. Interviewing is very time intensive and to gain the most from the interview, the interviewer should be extensively trained. Additional benefits and weaknesses of these two methods will be discussed in Chapter 3.

2.10 Diagnostic tests

Turning to the examination of available diagnostic tests, there are two groups: those tests associated with classical mechanics and those associated with electric circuits. The tests presented in this section will be examined on their use (diagnostic or assessment) and their construction.

2.10.1 Mechanics tests

Three tests in this area are the Force Concept Inventory (FCI), the Mechanics Baseline, and the Test for Understanding Graphs in Kinematics (TUG-K). A brief description of each test and its impact on the teaching community will be discussed.

The FCI was developed “to probe student beliefs on this matter [force] and how these beliefs compare with the many dimensions of the Newtonian concept” (Hestenes, Wells, & Swackhamer, 1992, p. 142). The test has been administered to students from high school through college, both pre- and post-instruction. Multiple questions were designed for each of the 6 main concepts for a total of 29 questions. The newest version of the FCI has 30 items. Each question has five options. Analysis of the results focused more on the errors students made than the correct choices. The FCI has been used and discussed widely since it was introduced in 1992 (Huffman & Heller, 1995; various AAPT Announcers since 1993). The main impact of this test was to open the eyes of instructors regarding students’ beliefs about the concept of force. Up until the FCI, instructors evaluated student understanding of material on in-class examinations. The FCI showed that students could perform well on the standard exams but poorly on the FCI.

Steinberg and Sabella (1997) have given open-ended exam problems corresponding to several Force Concept Inventory (FCI) questions on final examinations in calculus-based physics courses. Prior to the final exam, students were also given the FCI which is a conceptually-oriented multiple-choice test covering the concept of force. Steinberg and Sabella compared the results from these two styles of exams. They found that there were correlations between the two assessment instruments but that for certain students and questions, the responses differed greatly (p. 154). For the case of Newton's First Law, of the students taking both exams, 54% answered the FCI question correctly while 90% answered the open-ended exam question correctly. They gave an anecdote by Eric Mazur, "Upon looking at questions like those on the FCI, one student asked: 'Professor Mazur, how should I answer these questions? According to what you taught us, or by the way I think about these things?'" (p. 153).

The Mechanics Baseline test (Hestenes & Wells, 1992) and FCI are often given together but there are differences between them. The Mechanics Baseline provides instructors with information on students' general understanding of basic concepts in mechanics. The FCI distracters probe students' beliefs, whereas the Mechanics Baseline distracters detect typical student mistakes.

The TUG-K uncovers student problems with the interpretation of kinematics graphs. This is an important aspect because instructors often assume students understand and can interpret the information presented on any graph that is presented to them. This 21 item test covering seven distinct objectives revealed some very important difficulties students' had. If the line did not pass through the origin, students had difficulty finding the slope. Students also had difficulty with interpreting the meaning of areas under curves and translating between reality and the abstract graphical representation (Beichner, 1994, p. 755).

2.10.2 Electric circuits tests

Several researchers have developed pencil-and-paper questionnaires to explore students' understanding of electric circuits. The questionnaires examine simple electric circuits. The three types of tests, research oriented, computerized and assessment, will be discussed in this section.

2.10.2.1 Research-oriented tests

Dupin and Johsua (1987) used a 44 item questionnaire to examine the evolution of DC electrical circuits concepts across grade (grade 6 through fourth year university) and to evaluate the impact of teaching on these conceptions (p. 793). The objective of the test was to delineate between easily overcome difficulties and those that would require more intensive remediation. Some of the items were borrowed from questionnaires by other authors to allow for comparisons. Questions contained bulbs, ideal batteries, and "realistic" representations of circuits as well as schematic diagrams. (see Figures 2.3 and 2.5) Some of the questions were true/false/I don't know. One difficulty with this type of format is the higher chance that students might guess. Even though the alternative "I don't know" is available, students may be hesitant to appear as if they don't know the material. Additionally, if a large number of students selected "I don't know," vital information about what they do think is happening is lost. Not all questions were given at each level. No statistical evidence of the questionnaire's reliability or validity was provided.

Johnstone and Mughol (1978) developed a 14 item test to examine student understanding of resistance. The test was constructed after interviews. Distracters were based on results from those interviews. The test was given to second through fifth year comprehensive students in Glasgow. The main limitation to this test is the restricted content.

Shipstone, von Rhöneck, Jung, Kärrqvist, Dupin, Johsua and Licht (1988) put together a 13 item test. Items were drawn from previous studies with which the authors were involved. The test was given to students ages 15-17 in five countries: England, France, the Netherlands, Sweden, and West Germany. The items were concerned with basic understanding of electric

circuits (see Table 2.14). The purpose was to examine if there were significant differences in understanding across countries. The items investigated one or two of the aspects listed in Table 2.14 and were mainly multiple-choice or true/false/I don't know. (See previous discussion for potential problems associated with true/false/I don't know.) An additional concern is that there is roughly one item per objective. It is difficult to assess a student's understanding of a particular topic via one data point. Perhaps, the student accidentally chose the wrong answer on the test form or misread the question. More points are needed to determine a student's understanding.

Table 2.14: Elements of understanding of simple circuits covered by the test (p. 305)

Question Number	Aspects tested
1	Need for a closed circuit Difference between current and voltage
2	Conservation of current in a circuit
3	Causal relationship between current and voltage Relationship between current and energy
4	Flow of charge in a simple circuit Flow of energy in a simple circuit
5	Phenomenology of simple series and parallel circuits
6	Conservation of current in a circuit
7	Voltages and currents in parallel circuit
8	Currents in a parallel circuit
9	Phenomenology of simple series and parallel circuits
10	Distribution of voltages across connecting leads and circuit elements
11	Repeated branching of current in a parallel circuit
12	Influence of ordering of components on behaviour of a series circuit Effects of changing resistance values
13	Currents in a parallel circuit Effects of changing resistance values

Cohen, Eylon and Ganiel (1983) developed a 14 item questionnaire containing 10 multiple-choice items and 4 open-ended items. Interviews were conducted with 14 students after taking the exam to ascertain their reasoning behind their selections. Items were mainly qualitative and were designed to explore students' understanding of the functional relationships between variables in electric circuits. Some circuits contained batteries with internal resistance. The questionnaire was given to high school students and physics teachers. Aside from the lack of statistical evidence of the questionnaire's reliability and validity, the sample and item sizes are small. Large sample sizes reduce the chance of sampling errors (Best, 1981, p. 14). The sample also does not contain university students. The questionnaire also uses ammeters which research indicates students do not fully understand (see section 2.7.2). This does not appear to be taken into consideration by the authors. Some of the circuits are quite complex containing combinations of resistors and light bulbs. The complexity of the circuits requires students to synthesis a large number of variables and conditions simultaneously which is quite difficult.

Licht and Thijs (1990) developed a 20 item diagnostic test to examine the consistency and persistence through schooling of alternative conceptions. The questions were modifications of those used by Closset, Shipstone, and von Rhöneck. Items were multiple-choice. Some circuits were depicted "realistically" and some contained meters. The test was given to 230 students ages 13-18 in the Netherlands. A factor analysis was performed on the distracters in order to categorize alternative conceptions. The factor analysis revealed 3 alternative answer choices: current consumed, battery as a constant current source, and local/sequential reasoning. The authors do provide evidence of the reliability of the scales derived from the factor analysis, but not the overall exam. There is no evidence of validity except that their results show a similar trend to that reported by the researchers whose questions have been modified. The sample size is somewhat low at 230 students with an

average of 46 ± 16 students at each level and is restricted to only high school age students. Ammeters are again used to determine the amount of current.

Millar and King (1993) constructed a test to examine students' understanding of voltage. Each item on the test was designed to test one aspect of the knowledge needed to analyze the circuit shown in Figure 2.22. The test was given to students age 15. The main objections to this test are the domain and sample restrictions and the use of one item per objective.

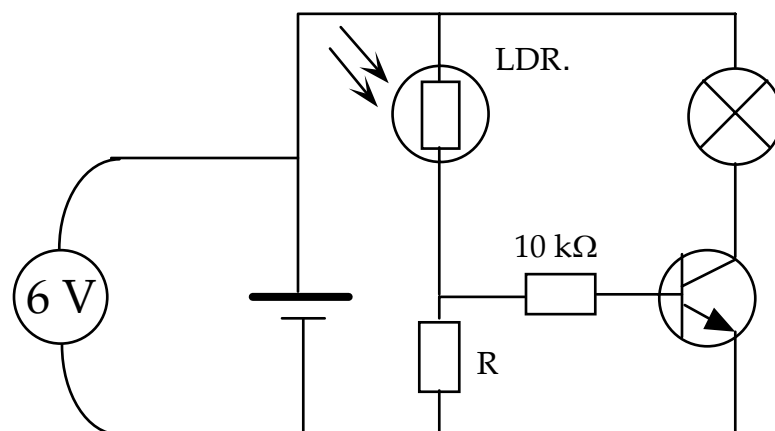

Figure 2.22: A simple electronic circuit using a voltage divider for the input stage (Millar & King, 1993, p. 340)

Sebastià (1993) used a 15 item multiple-choice exam that consisted of items adapted from Shipstone et al. (1988) and Dupin and Johsua (1987). The test was administered to 273 university students in Venezuela. The test was constructed with emphasis on students' use of sequential and superposition reasoning. The test's applicability is limited by the restrictive sample as well as the small number and focus of the items.

Picciarelli, DiGennaro, Stella, and Conte (1991 a and b) used tests developed by Shipstone, Closset, and Cohen et al. to examine university students understanding of circuits.

They analyzed the results from the test composed of questions from Closset and Shipstone as either static or dynamic. Questions categorized as static meant the question was presented and required knowledge on the operational nature of the circuit. With questions categorized as dynamic, a change was made to the circuit and the specific behavior of the circuit before and after the change was examined. The authors of this study, basically, used the same versions of the tests; thus, the problems have already been discussed.

2.10.2.2 Computerized tests

The following two studies are included to show that there are viable alternative ways to administer a multiple-choice test. The main disadvantage to using this method is the availability of computers and the possible costs of the software needed to run such programs. The advantages are that the results appear to be similar to standard pencil-and-paper versions and that the results are more readily available in a format that eases statistical analysis.

Lea, Thacker, Kim and Miller (1994) have developed a computerized diagnostic test to measure students' understanding of electric circuits. The problems are derived from the *Physics by Inquiry* materials developed by the Physics Education Group at the University of Washington. The purpose is to evaluate students' understanding against their previous knowledge and to diagnose learning problems or misconceptions. The computerized version was found to give similar results to conventional methods.

Grob, Pollak, and von Rhöneck (1992) developed a computerized diagnostic test used to study changes in students' conceptions when they received various amounts of feedback from no information to detailed information. Feedback was given to solutions in part 1 and was to be applied to questions in part 2. Items were those used by the authors in previous studies. After instruction, students ages 15-17 in Germany were given eight pairs of exercises with similar but not identical tasks. Results indicated no significant differences across feedback only across schools.

2.10.2.3 Assessment tests

Assessment tests have been developed and used by the authors of several curriculum approaches. Shaffer and McDermott (1992) use both pre- and post-testing to evaluate and revise the *Physics by Inquiry* materials and the Tutorials. Sokoloff (1994) has used a 16 item multiple-choice test to evaluate the Electric circuits component of the *Real-Time Physics* materials. The test produced by David Brown in association with the CASTLE materials was produced to determine conceptual gains (Steinberg & Wainwright, 1993). Included in the materials for the *PSI-PET Electricity Unit* are examples of final and unit exams that were used to initially assess the success of the materials.

These types of tests are limited by the samples to whom they are given and the types of questions that are presented. Many of these tests, with the exception of David Brown's, have items that are very similar to those presented in the curricular materials. David Brown's test was designed independently of the curriculum but in consultation with the teachers from CASTLE (Mel Steinberg, personal communication, January 28, 1997). It was not intended for research purposes or a broader sample (David Brown, personal communication, March 11, 1997). The results from such tests should be evaluated with caution. When items that are familiar to one portion of the sample are presented, those subjects would be expected to perform better than those who have not seen questions like that before.

2.11 How is DIRECT different?

The tests that have been discussed in the previous section vary in purpose and ages tested. Most of the tests are multiple-choice. They vary in the number of items presented and the type of multiple-choice (A,B, C ,etc. or True/False/I don't know) Some of the tests outline the objectives to be covered on the exam. Those that do often have a single item per objective. The literature does not describe in detail the method used to develop many of these tests. Statistics associated with the reliability and validity of these tests are almost non-existent.

Many of these tests have not been administered to a wide audience with differing abilities. The assessment tests, especially, have typically been given only to the groups under investigation.

DIRECT is similar to the above tests in that it incorporates many of the learning difficulties and misconceptions that students have been found to possess but it covers more topics than the other tests. It is not associated with any particular curriculum but does contain questions that students using certain curriculum may find familiar. This aspect is important since one desirable use of DIRECT is to evaluate the effectiveness of curriculum approaches designed to minimize students' conceptual difficulties. Having a test that is not specifically associated with a particular curriculum makes the results more valid and generalizable.

Like the other tests, DIRECT is multiple-choice and thus objective. It was developed based on a set of eleven objectives (which will be described later). Roughly three items were written per objective, this provides more evidence (more data points) for students' understanding of any particular objective.

Two techniques have been used to analyze the data: statistics and interviews. Twenty-eight interviews, more than used in many of the other studies, were conducted with high school and university students to establish the validity of the test as well as explore further why students chose certain distracters. Statistics were performed to evaluate the reliability and validity of the tests. These data are almost non-existent in the literature, but extremely important in evaluating the results that are obtained.

To have a good test, it must be both reliable and valid. Reliability is the consistency of the test in measuring what it does measure and validity is the extent to which a test measures what it is supposed to measure (Wiersma, 1969, pp. 185 and 190). Further discussions of these two measures will be discussed in Chapter 3. One point of criticism about the Force Concept Inventory was the lack of evidence that the test actually measures a "force concept" (Huffman & Heller, 1995, p. 138). As a result, the validity of the FCI is at risk. In part, to avoid this problem with DIRECT, a factor analysis was performed.

The test was administered to a much larger sample than the other tests, thus, further improving its generalizability and reducing the effects of sampling error. It is appropriate for use with students from high school through college and makes a connection between the research community and the classroom instructor. The following chapter will outline in detail the methodology used in this study.

Chapter 3

Methodology

The research design incorporates quantitative and qualitative techniques. A diagnostic instrument, Determining and Interpreting Resistive Electric circuits Concepts Test (DIRECT), was developed to assess students' understanding of simple direct current resistive electric circuits and to determine any underlying misconceptions. Individual interviews were conducted to understand why students chose particular distracters and to aid in validating the instrument. This chapter will outline the procedures followed and will present some of the statistical results associated with DIRECT.

3.1 Quantitative and Qualitative techniques

Prior to beginning the discussion of the exact methodology used, it is appropriate to discuss the advantages and disadvantages of the methods. This project used both quantitative and qualitative data. The quantitative data took the form of a multiple-choice test. The qualitative data came from individual interviews.

Multiple-choice exams have several advantages over other forms of data collection. They are objectively graded so there are minimal errors due to subjectivity. Statistical methods can be applied to the data. Since the test can be given to large groups of students at the same time, the results are more generalizable (Beichner, 1994, p. 750) and the process is less time intensive. The researcher does not have to be present at the time the exam is given, provided detailed instructions for its administration are available. The exam can cover "a wide range of behaviors from recall to the higher level skills," such as application (Doran, 1980, p. 41), and can "afford excellent content sampling, which generally leads to more content-valid score interpretations" (Mehrens & Lehmann, 1991, p. 132). If the distracters are based on student

misconceptions, then the items have the potential to give “diagnostic insight” into problems that individual students may be having (Nitko, 1983, p. 194). Multiple-choice items are free from response sets; “the tendency for an individual to give a different answer when the *same* content is presented in a different form” (Mehrens & Lehmann, 1991, p. 132).

There are, however, also disadvantages to using multiple-choice exams. The data is restricted in depth and in content to what is covered on the exam. Mehrens and Lehmann (1991) report that students who are test-wise perform better on multiple-choice tests than those who are not and “that multiple-choice tests favor high risk-taking students” (p. 133). They also note that students skilled at recognizing ambiguities perform better on multiple-choice tests than those who do not (p. 133). They report, too, that some test takers can recognize the correct answer without being able to reproduce it (p. 133). Tamir (1990) performed a study in which students were asked to justify their answer choices on a multiple-choice exam. He found that students were not able to adequately explain the reasons for their choices and contended that this suggests that multiple-choice exams overestimate knowledge (p. 571). He also noted a substantial gap between the percentage of students selecting the correct answer and the percentage of students providing a satisfactory justification. He concluded that “this gap indicates that a considerable number of students who choose correctly do not really understand the relevant subject matter” (p. 565). In part, this is why a combination of techniques were selected.

The second technique used in this project was individual interviews. Interviews have advantages over multiple-choice testing in that the format is not restricted in either the depth or the content. Once the interview begins, the interview can follow a variety of courses and move back and forth between them to gain the most information and understanding. Questions can be reworded and clarified so that the individual who is being interviewed can fully understand what is being asked. Although the depth and richness of the information that can be gathered through interviewing makes it an outstanding approach, there are some major disadvantages.

The technique is quite time consuming. The interviewer must be very well trained to get the most out of the interview. The data is open to misinterpretation as well as bias. The bias can come into play during the interview through the use of leading questions or during the analysis phase by forcing categorizations to fit the model. The data is not easily manipulated so that statistical methods can be employed (Best, 1981, p. 164-7; Brenner, Brown, & Canter, 1985, p. 3-4).

This project uses a combination of these two techniques. The combination minimizes the disadvantages of each method and capitalizes on the advantages. For example, as Tamir notes students who chose the correct answer may not be doing so because they know the answer. They could have simply guessed the correct answer. Using individual interviews allows the researcher to find this out and to estimate with what frequency this may be occurring in the large scale testing.

3.2 Sample

DIRECT was designed for use with high school and university students. Three samples of students were selected, one for each administration. *All* samples had completed both a unit on electrostatics and electricity prior to taking the exam. Sample 1 was a convenience sample consisting of 39 high school students taking either regular or Honors physics from Noblesville High School in Indiana and 40 university students taking a second course in introductory algebra-based college physics at North Carolina State University. Samples 2 and 3 were located via the internet. A message was placed on a listserv for physics education researchers and educators requesting test sites. Additional test sites were obtained from contacts made during the 1993 Physics Courseware Evaluation Project's (PCEP) Summer Teachers' Institute held at North Carolina State University. Tables 3.1-3 show the breakdown of test sites. More details are given in Appendix A. The large sample sizes were need to reduce

the magnitude of sampling error (Best, 1981, p. 14). Possible limitations due to the samples will be discussed in Chapter 5.

Table 3.1: Sample 1 - Open-ended version

	Average Age	Number of students	Number of Females	Number of Males
Noblesville High School, Indiana - Physics 1	16.8	33	20	13
Noblesville High School, Indiana - Physics 1 Honors	16.2	6	4	2
High school totals	16.7	39	24	15
North Carolina State University - Introductory Algebra-based College Physics	21.6	40	23	17

Table 3.2: Sample 2 - DIRECT version 1.0

	Number of Test Sites	Average Age	Number of students	Number of Females†	Number of Males†
High School	6	18.0	454	174	261
University	7*	21.8	681	56	176
Combined	13‡	19.2	1135	230	437

†Numbers are based on those students who responded

*Includes North Carolina State University as a test site. This site was composed of three different classes.

‡All test sites were located in the United States

Table 3.3: Sample 3 - DIRECT version 1.1

	Number of Test Sites	Average Age	Number of students	Number of Females†	Number of Males†
High School	4*	18.0	251	174	261
University	14‡	21.8	441	56	176
Combined	18	19.2	692	230	437

†Numbers are based on those students who responded

*One test site in Germany and one in Canada; remainder in the United States

‡One test site in Canada; remainder in the United States

3.3 Development of DIRECT

The initial step was to construct a set of instructional objectives for the test. Construction of the objectives for DIRECT involved an extensive examination of both high school and university textbooks and laboratory manuals and informal discussions with high school and university instructors. Appendix B lists the textbooks and laboratory manuals that were reviewed. The final eleven objectives were culled from this review and organized into four main categories. The categories are: (a) Physical aspects of DC electric circuits, (b) energy, (c) current and (d) potential difference (voltage). The objectives were given to an independent panel of experts in a rough format for comment. There were twelve members on the panel; six high school teachers from the 1993 PCEP Summer Teacher Institute and six college/university professors. This panel was made up of highly, motivated high school teachers and university instructors who are involved with physics education research and curriculum development projects to improve the physics curriculum. Their comments and suggestions were incorporated and formed the final objectives shown in Table 3.4.

Table 3.4: Objectives for DIRECT

Upon completion of a unit on direct current electric circuits and a prior unit on electrostatics, students will be able to do the following:

Physical aspects of dc electric circuits

- 1) to identify and to explain a short circuit (more current follows the path of lesser resistance)
- 2) to understand the functional two-endedness of circuit elements (elements have two possible points with which to make a connection)
- 3) to identify a complete circuit and to understand the necessity of a complete circuit for current to flow in the steady state (some charges are in motion but their velocities at any location are not changing and there is no accumulation of excess charge anywhere in the circuit)
- 4) to apply the concept of resistance (the hindrance to the flow of charges in a circuit) including that resistance is a property of the object (geometry of object and type of material with which the object is composed) and that in series the resistance increases as more elements are added and in parallel the resistance decreases as more elements are added
- 5) to interpret pictures and diagrams of a variety of circuits including series, parallel, and combinations of the two

Energy

- 6) to apply the concept of power (work done per unit time) to a variety of circuits
- 7) to apply a conceptual understanding of conservation of energy including Kirchhoff's loop rule ($\sum V=0$ around a closed loop) and the battery as a source of energy

Current

- 8) to understand and to apply conservation of current (conservation of charge in the steady state) to a variety of circuits
- 9) to explain the microscopic aspects of current flow in a circuit through the use of electrostatic terms such as electric field, potential differences, and the interaction of forces on charged particles

Potential difference (Voltage)

- 10) to apply the knowledge that the amount of current is influenced by the potential difference maintained by the battery and resistance in the circuit
- 11) to apply the concept of potential difference to a variety of circuits including the knowledge that the potential difference in a series circuit sums while in a parallel circuit it remains the same

One typical comment that the panel made was the omission of the use of meters in terms of their placement in circuits and as a measurement device to determine the behavior of the circuit. Although an important part of laboratory work, they serve as an application of electric circuits concepts as opposed to a distinct concept of their own. As section 2.7.2 indicated, students have misconceptions regarding these measurement devices believing that they consume current. If such devices were included on the exam, it would be difficult to determine if students were having difficulties with circuit concepts like current or if they were having difficulties with the use and the function of the meters. Additionally, there are other ways to determine circuit properties on the exam without using meters. Bulb brightness can be an indication of the amount of current. Various points in the circuit can be labeled and the voltage between two points can be investigated. Thus, the use and application of meters was not included for these reasons.

Based on these eleven objectives, three items were written per objective for a total of 30 items. Three items per objective provides more statistical evidence of understanding than one or two items while not producing an excessive number of total questions. Using three questions per objective also allows comparisons to be made between items that supposedly relate to the same objective. For example, three questions, each using a different mode of representation, were written for objective 5 which deals with circuit diagrams. The three modes were verbal to schematic, “realistic” to schematic, and schematic to “realistic.”

The three questions originally written for objective 2 were removed because they provided the test taker with information needed to answer other questions. Objective 2 was linked with items written for objectives 1 and 3. Some items were adapted from the *Physics by Inquiry* materials and *College Physics* textbook by Serway and Faughn. Most of the items were original.

Efforts were made not to align the questions with any one particular approach so that the results would be the most useful and generalizable to the largest possible audience. The

only except was with regards to the questions written for the microscopic aspects of circuits. In the multiple-choice versions of the test, these questions were closely aligned with the approach proposed by Chabay and Sherwood in their text, *Electric and Magnetic Interactions* . These questions were included to provide evidence that students do not understand the microscopic aspects of circuits and that efforts like Chabay and Sherwood should be undertaken to bridge this gap in students' knowledge.

3.3.1 Validity check 1 and Field test 0 - Open-ended version

An important and vital characteristic of any test is its ability to measure what it is intended to measure. The term used to describe this characteristic is validity. Validity is not a quality that can be established by a single measurement. Evidence for validity is accumulated via several measurements. Data establishing the content (Does the test cover the appropriate material?) and construct (Does the test measure electric circuit concepts like current, voltage, etc.?) validity of DIRECT were obtained. The content validity was established via independent panels of experts (see Table 3.5 for a list of the members) while the construct validity was established through individual interviews and factor analyses.

Table 3.5: List of independent panel of experts

1995		1996†
Name	Affiliation	Faculty
Mark Ailes	Addison Trail HS	John Gastineau
Sister M. C. Burns	Coyles and Cassidy HS	David Haase
Bernie Clemens	Sycamore HS	John Hubisz
Mark Davids	Gross Pointe HS	Elizabeth Rieg
Dewey Dykstra	Bosie State University	
Joan Dutter	Walton HS	Graduate Students
Uri Ganiel	The Weizmann Institute of Science	Eric Ayars
Marvin Giesting	Connersville HS	Duane Deardorff
Ibrahim Halloun	Arizona State University	Brook Henderson
Bobbie Himes Lang		Andrew White
Sue Lea	University of North Carolina at Greensboro	
Tom Odden	St. Andrews School	
Stephen Reynolds	NCSU	
Bruce Sherwood	Carnegie Mellon University	
Mel Steinberg	Smith College	
Beth Thacker	Grand Valley State University	

†All members were affiliated with North Carolina State University (NCSU).

Content validity is established by presenting the test and objectives to an independent panel of experts. The panel examines the test and objectives to see if it covers the domain adequately. Then, the panel takes the test and matches test items with objectives. This yields a percentage agreement for the answer key as well as the objectives. The comments of the independent panel of experts were used to revise the test. For example, at least two of the panel members noted that there were no questions dealing with the voltage across an open circuit. Mel Steinberg (personal communication, February 3, 1995) suggested that the question in Figure 3.1 be added to address this omission.

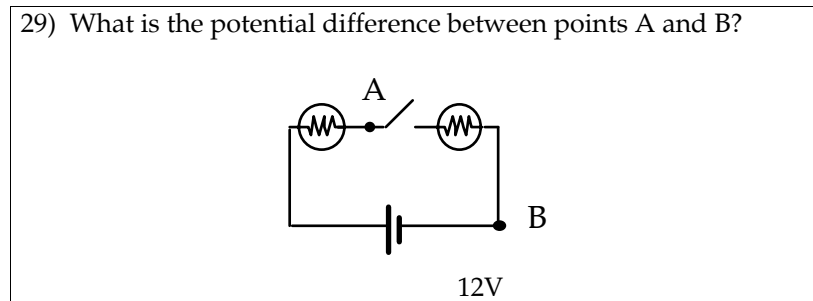

Figure 3.1: Question 29 of the open-ended version

Additional evidence is provided by individual interviews with groups of students after they have completed the test. Students were interviewed to uncover any problems with the wording of the questions or the figures used. This provides information on whether the questions are being understood in ways contrary to what the developer has intended. To illustrate this, consider question 15 shown in Figure 3.2. A couple of the students misinterpreted what was meant by “bulb A is removed.” They believed that the bulb was removed and replaced by a wire. As a result, the circuit was changed to include a switch (see Figure 3.3). The form of the question was also changed as can be seen in the figure. This was the result of adding alternatives to the questions so that nearly all questions contained five answer choices.

15) What happens to the potential difference between points 1 and 2 if bulb A is removed?

(A) Increases
(B) Decreases
(C) Stays the same

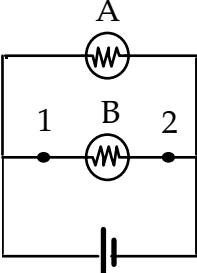

Figure 3.2: Question 15 from DIRECT version 1.0

15) What happens to the potential difference between points 1 and 2 when the switch is closed?

(A) Quadruples (4 times)
(B) Doubles
(C) Stays the same
(D) Reduces by half
(E) Reduces by one quarter (1/4)

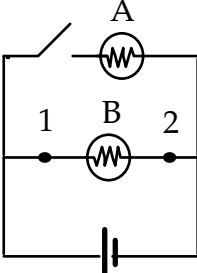

Figure 3.3: Question 15 from DIRECT version 1.1

The results from the validity check of the open-ended version of the test showed agreement on objectives at 74% and on the answer key at 93%. The number of panel responses was low. Only eight gave responses to the test and of those, six matched objectives with items. All twelve panel members made informal comments and suggestions with regard to the questions. Agreement on the objectives is low, one would prefer values in the 80-90% range. Although each question was written to address a particular objective, the test involves items

that require the test taker to utilize additional information not specifically asked by the question. Because of this, some questions did address more than one objective. It was typical for the panel to list all possible objectives that would apply to the test item under consideration. At this stage, it was found that some items were not written clearly enough for the panel to distinguish precisely what was intended.

Based on the suggestions and corrections made by the independent panel of experts, the test was revised. This revision included some items specifically suggested by the panel. The test now consisted of 30 items with a variable number of items per objective. The open-ended version (see Appendix C) was given to students in Sample 1. The answers students gave to the test were used to develop the distracters for the multiple-choice version. The distracters were selected after the answers were categorized. A subset of the questions was given to another researcher to categorize the question responses. The two categorizations were compared and the multiple-choice alternatives were developed. The top two to four responses were used along with the correct answer to form the final multiple-choice alternatives.

There were two questions (Questions 20 and 21) on the open-ended version that none of the students answered correctly. Distracters for question 20 were developed by the researcher. Question 21 was suggested by Mel Steinberg (personal communication, February 3, 1995). Question 21 was eliminated and not replaced. This question was particularly complex (see Figure 3.4). The objective being tested by this item was sufficiently explored by other items on the test so that removing it was not a problem. Additional wording changes and clarifications were made. For example, question 3 was changed as shown in Figures 3.5 and 3.6.

21) Which of the five circuit elements are gaining energy and which are losing energy?

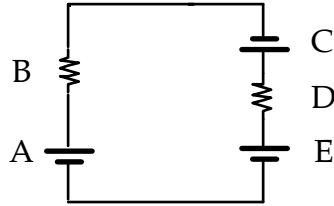

Figure 3.4: Question 21 from open-ended version of DIRECT

3) Rank the energy delivered each second to the light bulbs shown in the circuits below from lowest to highest.

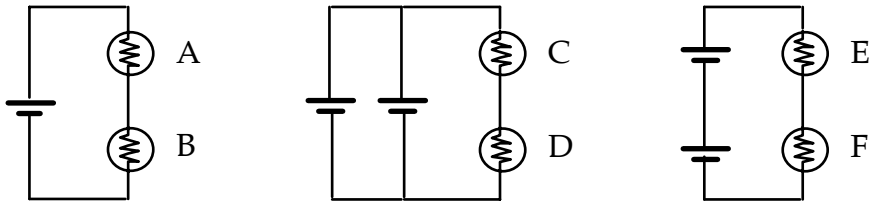

Figure 3.5: Question 3 as it appeared on the open-ended version

3) Consider the circuits shown below. Which circuit or circuits have the greatest energy delivered to it per second?

(A) Circuit 1

(B) Circuit 2

(C) Circuit 3

(D) Circuit 1 = Circuit 2

(E) Circuit 2 = Circuit 3

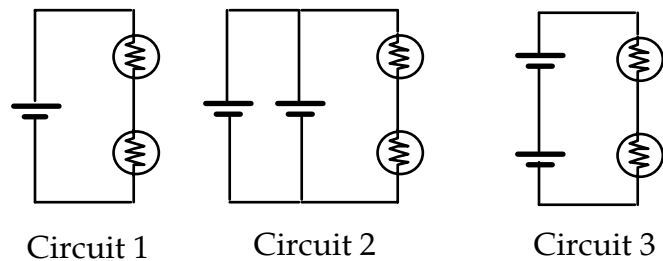

Figure 3.6: Question 3 as it appeared on DIRECT version 1.0

3.3.2 Field Test 1 - DIRECT version 1.0

The multiple-choice version 1.0 was administered in the Spring of 1995 to students in Sample 2. The test consisted of 29 items with a variable number of alternatives ranging from 3 to 5. (See Appendix D) The test took approximately half an hour to complete. The statistical analysis of the test is presented in Table 3.6 along with information about the statistics and their ideal values (Beichner, 1994, p. 752; Doran, 1980, Chpt. 5; Kline, 1986, Chpts. 1 and 6).

Table 3.6: Statistical results for DIRECT version 1.0

Statistic	Value	Ideal value	What it measures
Overall Mean	48 ± .45%	50% for maximum spread of scores	
University Mean	52 ± .56%		
High school Mean	41 ± .65%		
Standard error of the mean	0.45	As close to zero as possible	Uncertainty in the mean
Overall Range	14 - 97%	0 - 100	
University Range	21 - 97%	0 - 100	
High school Range	14 - 90%	0 - 100	
Kuder-Richardson 20 (KR-20) or Reliability	0.71	≥ 0.70 for group measurement	Consistency of the measurement
Average Point-biserial correlation	0.33	≥ 0.20	Reliability of a single item on the test
Average discrimination index	0.26	≥ 0.30	Ability of a single item to differentiate between students scoring well on the test and students scoring poorly
Average difficulty index	0.49	0.40 - 0.60	Proportion of students in the sample who chose the correct response

As Table 3.6 shows, the value of the KR-20 is just acceptable for discussing group measurements. It is possible to improve this value by increasing the number of items, or by improving the discrimination of the items and by maintaining an average difficulty of 0.50. Having an average difficulty of 50% maximizes the spread of scores (Doran, 1980, Chpt. 5). The KR-20 can also be improved slightly to 0.72 by removing questions 20 and 28. These two questions have the lowest discrimination index and were also two of the more difficult (in this case, having a high number of incorrect responses) questions on the test. The variability in the number of alternatives may have influenced the KR-20. When there were three options (percent chance of guessing is 33), students had a better chance at guessing the correct answer than when there were five options (percent chance of guessing is 20). This could have unduly influenced the discrimination index. Thus, increasing the number of alternatives available on each question to five is one option. Additionally, the low discrimination value could be indicative of the persistence of some misconceptions held by the students. By examining the average difficulty index, one may assume that the test is not that difficult but this would be incorrect. Figure 3.7 shows a distribution of the raw scores that is positively skewed which indicates a difficult test. For these and other reasons, it became necessary to develop a second version of the test in an attempt to improve the statistics.

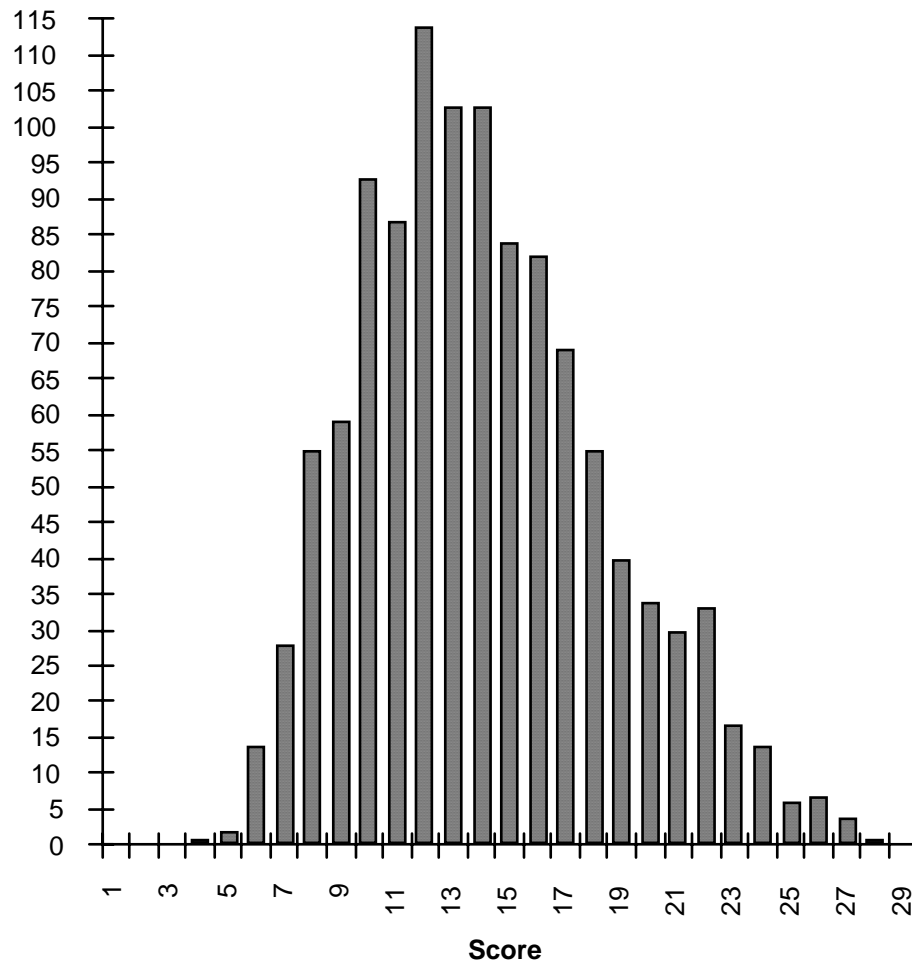

Figure 3.7: Distribution of scores for DIRECT version 1.0 for the overall sample

3.3.3 Validity Check 2 - Individual Interviews

To further evaluate DIRECT version 1.0, individual interviews were conducted as part of the validity check. Ten questions were selected based on the pattern of answer choices, interest in the students' reasoning, possible misinterpretation of the question, and statistical results. The ten questions were numbers: 3, 8, 10, 15, 16, 20, 22, 23, 28, and 29.

Students were selected for individual interviews based on what course they were taking and on their answers to the multiple-choice exam. Student responses to the ten questions that were selected for further study were grouped together so that a sampling of students who answered the questions incorrectly and some who answered the questions correctly were chosen. For a given question, if there were several different answer selections made, efforts were made to include students having chosen different answers. Attempts were made to have at least three students from each university level course participate in the interviews. This was done to see if there were any differences between the various course levels: honors, calculus, and algebra. At least three students from each class period were selected at the high school level. The resulting sample consisted of 17 students from North Carolina State University taking honors, engineering, and college physics courses and 11 advanced placement students at Enloe High School, which is a magnet school for science and mathematics.

All interviews were conducted by the author. Interviews lasted approximately 30 to 40 minutes each. Each session was audio taped and later transcribed by the author. Any notes that students made during the interview were collected. The interview was semi-structured and made use of the think-aloud procedure, which required students to verbalize aloud their thoughts as their ideas emerged. The interview was divided into three parts: identification of symbols used on the test, definition of terms used on the test, and answering the test items and providing reasoning behind the choice. After each of the 10 questions, students were asked their confidence on their answer. The confidence range was 1 for low, 2 for in-between, and 3 for high. The student's answers to the multiple-choice exam were available during the interview. Students often changed answers from the multiple-choice test and were asked to recall what their reasoning was when they answered the test originally.

The interviews were analyzed to aid in determining the validity of the test and to uncover students' reasoning patterns. Each interview transcript was examined to determine

whether students' understood the symbols used, to determine what students' meant when using terms present on the test, and to categorize students' reasoning to answer choices. It was found that students understood and correctly identified 91% of the symbols used on the test. Students' answers to the test during the interview were categorized based on the common misconceptions. Interrater reliability was established with 15% of the sample at each level, high school and university. To do this, another researcher coded the interviews. Percentage agreement between the author and this researcher was 88%. This value is quite acceptable. The minimum value one would like to have is 80%. Additional results from the interviews will be presented in Chapter 4.

3.3.4 Field Test 2 - DIRECT version 1.1 and Validity check 3

Based on the results from DIRECT version 1.0 and the individual interviews, it was necessary to revise the test once again. Revision included adding more alternatives which caused the rewording of some questions. Some of the circuit diagrams were edited and the order in which some of the circuits were presented changed. The interviews revealed that students did not understand the light bulb in a socket symbol in question 18 so the circuits were re-drawn without the socket. Additional comments will be made about this in 4.2.1. Version 1.1 (see Appendix E) was given to students in Sample 3 in the Spring of 1996. The results are shown in Table 3.7.

Table 3.7: Statistical results for DIRECT version 1.1

Statistic	Value
Overall Mean	41 ± .55%
University Mean	44 ± .69%
High school Mean	36 ± .79%
Standard error of the mean	0.55
Overall Range	3.4 - 90%
University Range	10 - 90%
High school Range	3.4 - 76%
Kuder-Richardson 20 (KR-20) or Reliability	0.70
Average Point-biserial correlation	0.32
Average discrimination index	0.23
Average difficulty index	0.41

As Table 3.7 shows, the KR-20 is again just acceptable for group measurements. The low value of the KR-20 could again be the result of the low discrimination and difficulty indices. This version of the test is not as discriminating as version 1.0 and it is more difficulty (more students answered incorrectly) than version 1.0 as well. The reliability could be improved by omitting either questions 11, 20 and 28 or questions 11, 20, 25, and 28. These questions have low discrimination and difficulty indices. The decreased discrimination and increased difficulty are most probably the result of the changes in the format of the test. Specifically, those questions, 2, 5, 14, 15, 16, and 25, that required the students to make a judgment as to how much brighter or by how much a quantity changed. These questions required that the students be proficient at using ratios and simultaneous changes in variables. These questions used light bulbs in the circuits. Bulbs are non-Ohmic and so do not obey Ohm's law. Thus, the power equations, $P = IV$, should not be used. However, this is exactly what these questions expect of the students. Unfortunately, this was an oversight in making the change from version 1.0 to version 1.1. In version 1.0, it was permissible to associate current

with brightness since the only judgments to be made were whether a bulb increased, decreased, or remained the same in brightness. No quantification was required. However, in quantifying the questions to add more alternatives, the physics behind the questions was unfortunately overlooked. The test again is positively skewed as is shown in figure 3.8.

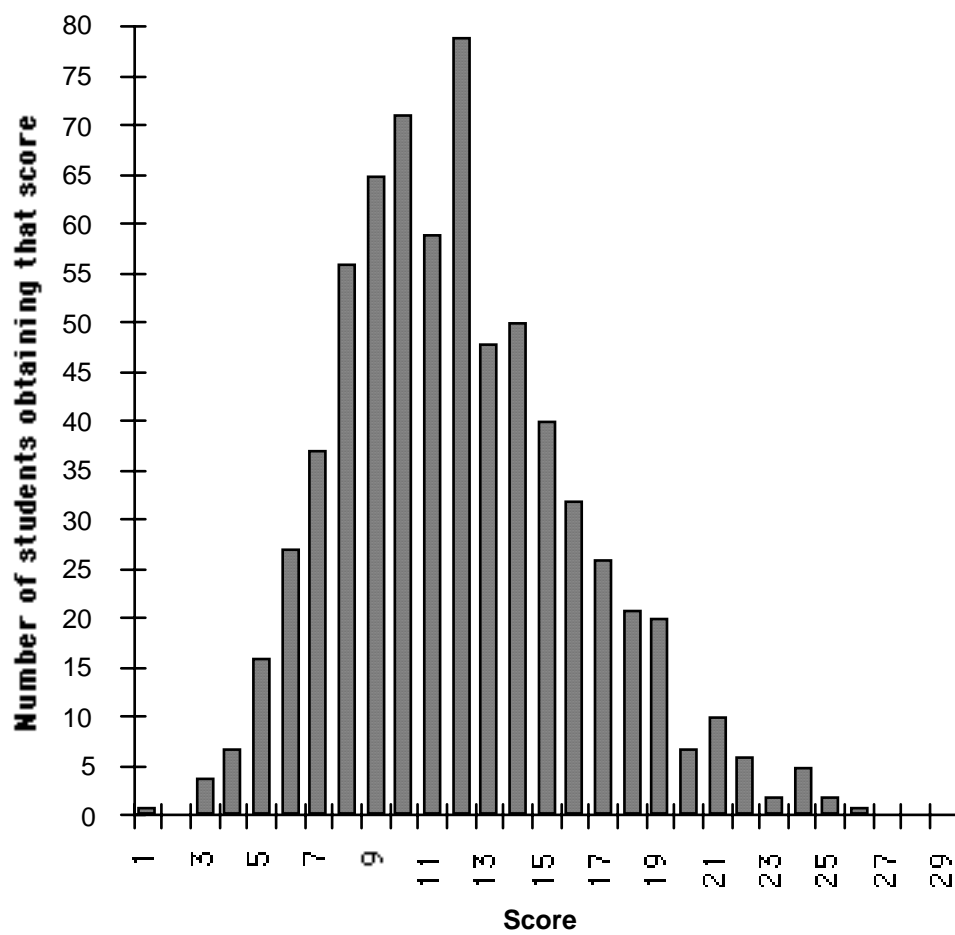

Figure 3.8: Frequency distribution of scores for DIRECT version 1.1 for the overall sample

DIRECT version 1.1 was given to four university professors and four graduate students at North Carolina State University. The group was asked to take the exam, comment on the questions and objectives, and to match individual items with objectives. When matching objectives, the group was asked to list the primary objective first, followed by what they saw as secondary objectives second. An example was given with the instructions to help clarify what was expected (see Appendix F). The objectives are those shown in Table 3.4. Agreement on objectives was 63% with seven of the eight responding and on the answer key 91% agreement with all eight responding. One would prefer to have both values be higher, although the percentage agreement on the answer key is not all that far out of line. Low agreement on the objectives could have two causes: multiple objectives listed and lack of experience by the graduate students. The lower agreement on the answer key compared to the earlier content-validity check may be due to misconceptions retained by some of the graduate students, misreading of the questions, or carelessness in responding to the questions. As noted in Chapter 2, some misconceptions are very resistant to change even with years of additional education.

3.4 Summary

This chapter presented the development of a multiple-choice diagnostic test called Determining and Interpreting Resistive Electric Circuits Concepts Test. Individual interviews were used as an aid in the establishing the validity of the test and for uncovering student reasoning patterns. Chapter 4 will discuss additional results from the administrations of the multiple-choice versions of DIRECT and address aspects of the research questions.

Chapter 4

Analysis of Data

In chapter 3, the methodology of this research project was discussed and some of the initial data from the multiple administrations of DIRECT were presented. Additional analysis of the two versions of the test, 1.0 and 1.1, will now be discussed as well as the results from the interview data. The foundation for answering the research questions will be presented. The specific answers to the research questions will be presented in Chapter 5.

4.1 DIRECT version 1.0

The discussion of the analysis of version 1.0 will be divided into four sections beginning with an examination of the questions with respect to discrimination and difficulty. Next, student performance on each of the objectives will be presented. An examination of individual and groups of questions will be presented. Results from multiple student's *t*-tests will also be discussed.

4.1.1 DIRECT version 1.0 Discrimination and Difficulty indices

Examining the discrimination indices (see Tables 4.1-3; Graphical representation of the first five columns of Table 4.1 can be found in Appendix G) for the 29 questions revealed that question 26 was the most discriminating (see Figure 4.1). That is to say, it does the best job in separating those students who scored well overall on the test and those who did not. Students who did well on this particular item had to understand that increasing the resistance of resistor C would increase the total resistance in the circuit. This increase in resistance would result in a decrease in overall current. Since current is the same for all elements in series, the brightness of bulbs A and B would decrease. Students could not reason

Table 4.1: Overall results for DIRECT version 1.0

Question Number and Correct Answer	A	B	C	D	E	Omitted	Point biserial correlation	Discrimination	Difficulty
1 D	0.20	0.03	0.32	0.46	0.00	0.00	0.33	0.29	0.46
2 B	0.13	0.55	0.32	0.00	0.00	0.00	0.30	0.21	0.55
3 C	0.04	0.31	0.42	0.05	0.18	0.00	0.35	0.26	0.42
4 D	0.08	0.03	0.30	0.43	0.16	0.00	0.38	0.33	0.43
5 B	0.10	0.78	0.11	0.00	0.00	0.00	0.37	0.27	0.78
6 E	0.15	0.06	0.06	0.15	0.58	0.00	0.41	0.36	0.58
7 A	0.63	0.10	0.27	0.00	0.00	0.00	0.30	0.22	0.63
8 C	0.17	0.03	0.80	0.00	0.00	0.00	0.37	0.26	0.80
9 D	0.12	0.04	0.03	0.79	0.01	0.00	0.32	0.24	0.79
10 E	0.02	0.01	0.53	0.11	0.33	0.00	0.14	0.09	0.33
11 A	0.33	0.11	0.21	0.36	0.00	0.00	0.18	0.10	0.33
12 D	0.37	0.16	0.13	0.19	0.14	0.00	0.39	0.22	0.19
13 A	0.89	0.04	0.01	0.01	0.04	0.00	0.29	0.15	0.89
14 B	0.30	0.57	0.13	0.00	0.00	0.00	0.40	0.32	0.57
15 C	0.36	0.12	0.52	0.00	0.00	0.00	0.31	0.24	0.52
16 C	0.24	0.26	0.49	0.00	0.00	0.00	0.17	0.09	0.49
17 D	0.02	0.11	0.13	0.44	0.30	0.00	0.44	0.35	0.44
18 C	0.00	0.02	0.28	0.68	0.01	0.00	0.32	0.21	0.28
19 C	0.03	0.13	0.67	0.08	0.08	0.00	0.33	0.26	0.67
20 D	0.14	0.08	0.63	0.15	0.00	0.00	0.07	0.01	0.15
21 D	0.07	0.04	0.23	0.51	0.16	0.00	0.43	0.34	0.51
22 B	0.02	0.32	0.18	0.04	0.44	0.00	0.33	0.29	0.32
23 C	0.09	0.11	0.41	0.39	0.00	0.00	0.35	0.28	0.41
24 D	0.47	0.06	0.16	0.25	0.05	0.00	0.46	0.29	0.25
25 A	0.69	0.04	0.27	0.01	0.00	0.00	0.36	0.27	0.69
26 D	0.37	0.05	0.07	0.45	0.06	0.00	0.51	0.43	0.45
27 B	0.06	0.68	0.10	0.15	0.00	0.00	0.42	0.38	0.68
28 D	0.56	0.03	0.19	0.21	0.00	0.02	0.07	0.00	0.21
29 B	0.31	0.31	0.16	0.10	0.10	0.02	0.38	0.28	0.31
Average							0.33	0.24	0.49

Table 4.2: University results for DIRECT version 1.0

Question Number	A	B	C	D	E	Omitted	Point Biserial Correlation	Discrimination	Difficulty
1	0.15	0.01	0.30	0.53	0.00	0.00	0.26	0.22	0.53
2	0.14	0.52	0.33	0.00	0.00	0.00	0.37	0.28	0.52
3	0.02	0.34	0.44	0.05	0.14	0.00	0.40	0.29	0.44
4	0.08	0.01	0.22	0.51	0.17	0.00	0.29	0.22	0.51
5	0.09	0.84	0.07	0.00	0.00	0.00	0.32	0.21	0.84
6	0.15	0.04	0.03	0.12	0.66	0.00	0.38	0.35	0.66
7	0.61	0.09	0.29	0.00	0.00	0.00	0.37	0.31	0.61
8	0.15	0.02	0.84	0.00	0.00	0.00	0.34	0.23	0.84
9	0.09	0.03	0.01	0.85	0.01	0.00	0.26	0.14	0.85
10	0.03	0.01	0.52	0.10	0.34	0.00	0.14	0.05	0.34
11	0.30	0.10	0.24	0.36	0.00	0.00	0.21	0.13	0.30
12	0.32	0.16	0.13	0.22	0.17	0.00	0.40	0.25	0.22
13	0.94	0.01	0.01	0.00	0.03	0.00	0.18	0.09	0.94
14	0.26	0.63	0.11	0.00	0.00	0.00	0.45	0.37	0.63
15	0.32	0.12	0.56	0.00	0.00	0.00	0.31	0.26	0.56
16	0.22	0.26	0.51	0.00	0.00	0.00	0.20	0.13	0.51
17	0.01	0.10	0.09	0.49	0.31	0.00	0.42	0.32	0.49
18	0.00	0.01	0.31	0.67	0.00	0.00	0.41	0.28	0.31
19	0.03	0.10	0.70	0.09	0.09	0.00	0.29	0.15	0.70
20	0.12	0.05	0.69	0.14	0.00	0.00	0.07	0.01	0.14
21	0.07	0.01	0.23	0.51	0.17	0.00	0.47	0.41	0.51
22	0.00	0.41	0.14	0.01	0.43	0.00	0.26	0.22	0.41
23	0.06	0.10	0.46	0.37	0.00	0.00	0.27	0.22	0.46
24	0.47	0.03	0.14	0.30	0.06	0.00	0.47	0.35	0.30
25	0.70	0.03	0.26	0.00	0.00	0.00	0.38	0.29	0.70
26	0.40	0.03	0.05	0.48	0.05	0.00	0.54	0.45	0.48
27	0.02	0.78	0.07	0.12	0.00	0.00	0.40	0.28	0.78
28	0.63	0.00	0.14	0.22	0.00	0.01	0.01	-0.01	0.22
29	0.32	0.42	0.12	0.08	0.06	0.01	0.40	0.35	0.42
Average							0.32	0.24	0.53

Table 4.3: High school results for DIRECT version 1.0

Question Number	A	B	C	D	E	Omitted	Point Biserial Correlation	Discrimination	Difficulty
1	0.27	0.04	0.33	0.35	0.00	0.00	0.35	0.27	0.35
2	0.11	0.60	0.29	0.01	0.00	0.00	0.28	0.20	0.60
3	0.06	0.26	0.39	0.06	0.23	0.00	0.29	0.17	0.39
4	0.08	0.05	0.41	0.30	0.16	0.00	0.41	0.27	0.30
5	0.11	0.71	0.17	0.00	0.00	0.00	0.38	0.28	0.71
6	0.15	0.08	0.11	0.20	0.46	0.00	0.37	0.30	0.46
7	0.66	0.11	0.23	0.00	0.00	0.00	0.27	0.17	0.66
8	0.20	0.06	0.73	0.01	0.00	0.00	0.37	0.27	0.73
9	0.17	0.07	0.06	0.69	0.01	0.00	0.31	0.24	0.69
10	0.02	0.01	0.55	0.12	0.30	0.00	0.14	0.07	0.30
11	0.36	0.12	0.17	0.35	0.00	0.00	0.21	0.21	0.36
12	0.45	0.17	0.13	0.14	0.11	0.00	0.34	0.15	0.14
13	0.82	0.09	0.01	0.03	0.05	0.00	0.32	0.24	0.82
14	0.37	0.48	0.15	0.00	0.00	0.00	0.27	0.17	0.48
15	0.41	0.13	0.46	0.01	0.00	0.00	0.28	0.22	0.46
16	0.28	0.25	0.46	0.01	0.00	0.00	0.10	0.05	0.46
17	0.03	0.12	0.19	0.37	0.29	0.00	0.45	0.31	0.37
18	0.01	0.04	0.24	0.70	0.01	0.00	0.15	0.04	0.24
19	0.05	0.18	0.63	0.06	0.08	0.00	0.39	0.33	0.63
20	0.16	0.12	0.55	0.16	0.00	0.00	0.10	0.10	0.16
21	0.06	0.07	0.24	0.50	0.13	0.00	0.42	0.36	0.50
22	0.04	0.17	0.24	0.09	0.45	0.00	0.30	0.19	0.17
23	0.15	0.12	0.32	0.41	0.00	0.00	0.42	0.32	0.32
24	0.47	0.12	0.18	0.18	0.05	0.00	0.38	0.16	0.18
25	0.67	0.05	0.27	0.01	0.00	0.00	0.34	0.33	0.67
26	0.34	0.07	0.11	0.40	0.07	0.00	0.47	0.37	0.40
27	0.13	0.51	0.15	0.20	0.01	0.00	0.34	0.28	0.51
28	0.45	0.06	0.26	0.20	0.00	0.03	0.16	0.07	0.20
29	0.30	0.15	0.22	0.13	0.16	0.03	0.17	0.04	0.15
Average							0.30	0.21	0.43

sequentially or believe that the battery was a constant current source or that current is consumed.

26) If you increase the resistance C , what happens to the brightness of bulbs A and B ?

(A) A stays the same, B dims
 (B) A dims, B stays the same
 (C) A and B increase
 (D) A and B decrease
 (E) A and B remain the same

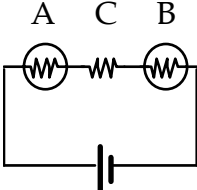

The diagram shows a rectangular circuit loop. At the bottom is a battery symbol. On the top horizontal wire, three resistors are connected in series. From left to right, they are labeled A, C, and B. Each resistor is represented by a circle with a zigzag line inside.

Figure 4.1: Question 26 from DIRECT version 1.0

For the university group and for all samples as a whole, questions 20 and 28 were the least discriminating. Even students who scored well on the test overall had difficulties with these questions. Question 20 (see Figure 4.2) deals with what causes a current in a bulb filament. The correct answer is that there are charges on the surface of the filament as a result of the potential difference maintained by the battery. These charges form a gradient which produces an electric field inside the filament. This field supplies the force the charges need to begin moving. This microscope view of what goes on inside the circuit is usually not discussed in introductory courses. As Cohen, Eylon and Ganiel (1983) have noted, this lack of a causal relation may be the cause of some of the problems students have with electric circuits. This question and questions 1 and 11 were put into the test to explore and to provide evidence that students do not have a clear understanding of the underlying mechanisms of electric circuits.

Question 28 (see Figure 4.3) deals with the battery being a source of constant potential difference. Students tended to choose option A which states that the potential difference between points A and B is zero. They come to this answer by reasoning that since the current is

zero, the voltage must also be zero. This is an example of current/voltage confusion. Students assume one of the following:

- 1) that the potential difference is a property of the current and since there is no current, there can be no voltage,
- 2) more simply when there is one, there is the other. They always come together, or
- 3) current causes the voltage so you must have current to have voltage.

20) Is the electric field zero or non-zero inside the tungsten bulb filament?

(A) Zero because the filament is a conductor.
 (B) Zero because there is a current flowing.
 (C) Non-zero because the circuit is complete and a current is flowing.
 (D) Non-zero because there are charges on the surface of the filament.

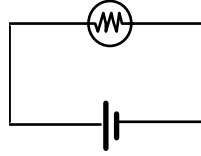

Figure 4.2: Question 20 from DIRECT version 1.0

28) What is the potential difference between points A and B?

(A) 0 V
 (B) 3 V
 (C) 6 V
 (D) 12 V

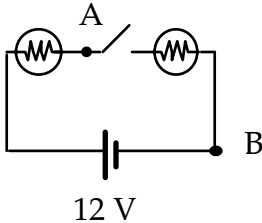

Figure 4.3: Question 28 from DIRECT version 1.0

For the high school group, question 18 (see Figure 4.4) was the least discriminating. This question shows four circuits containing a battery, some connecting wires, and a light bulb in a socket. Students identified circuits B and D as both being able to light the bulb. However,

circuit B although a complete circuit contains an additional wire which will short out the bulb. Thus, only circuit D will light the bulb. It seems that students can identify complete circuits but are unable to eliminate those that contain shorts.

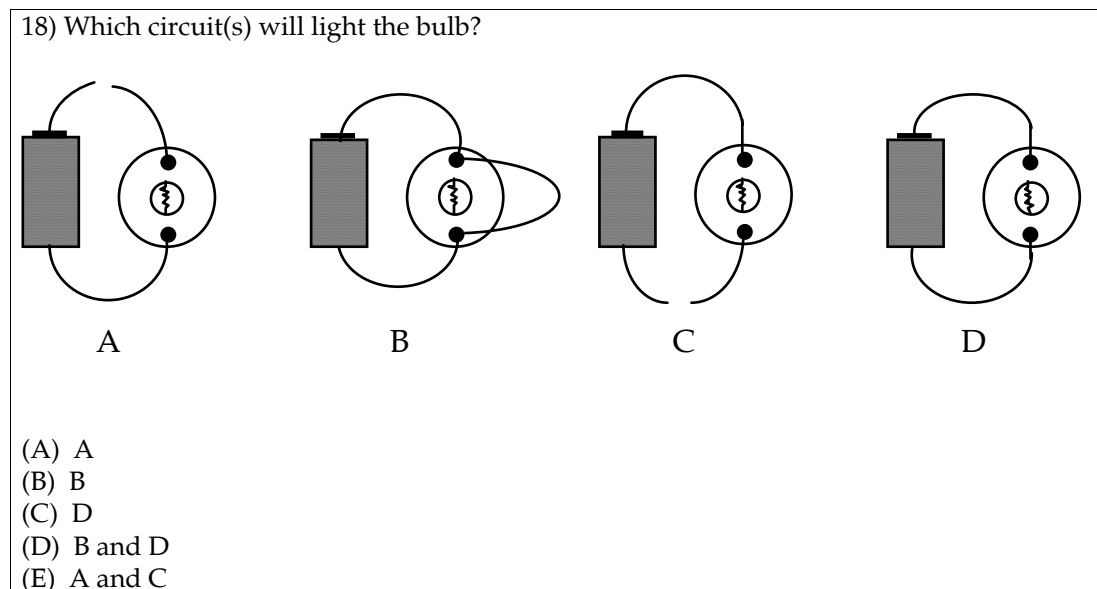

Figure 4.4: Question 18 from DIRECT version 1.0

Examining the difficulty of the individual questions shows that question 20 is the most difficult for the university group and for the group as a whole and question 13 (see Figure 4.5) is the easiest for all groups, combined, university and high school. Difficulty could be better termed the percent correct — the higher the value of the difficulty the easier the question is. As noted earlier, question 20 deals with the microscopic aspects of circuits and based on traditional instruction, students should have difficulty with this item. Question 13 is a diagram interpretation question. This particular question asks students to translate a picture of a “realistic” circuit to a schematic circuit. Students seem to be able to do this with very little difficulty. Question 12 (see Figure 4.6) is the most difficult for the high school group. This question asked students to determine which circuit or circuits will provide the

13) Which schematic diagram best represents the realistic circuit shown below?

- (A) A
- (B) B
- (C) C
- (D) D
- (E) None of the above

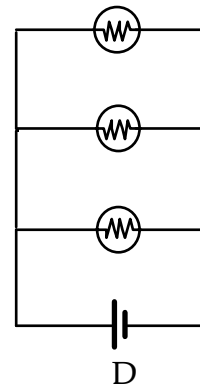
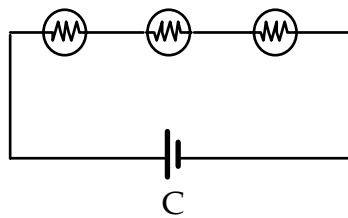
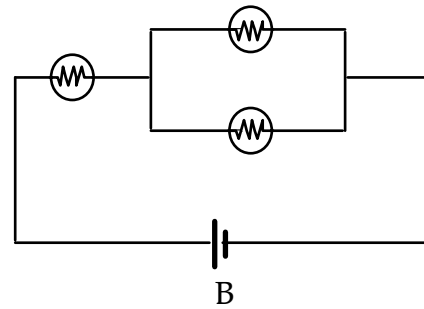
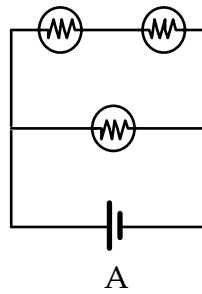
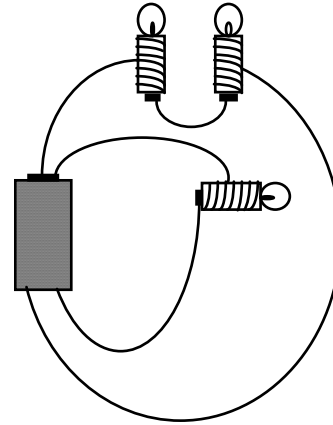

Figure 4.5: Question 13 from DIRECT version 1.0

least energy. The problem for many of the students is how batteries connected in series and parallel operate. This problem will be discussed further.

12) Consider the power delivered to each of the resistors shown in the circuits below. Which circuit or circuits have the least power delivered to it?

(A) Circuit 1
 (B) Circuit 2
 (C) Circuit 3
 (D) Circuit 1 = Circuit 2
 (E) Circuit 1 = Circuit 3

Circuit 1 Circuit 2 Circuit 3

Figure 4.6: Question 12 from DIRECT version 1.0

4.1.2 DIRECT version 1.0 Objectives

Both versions of the test are based on the 11 objectives presented in Table 3.4. These objectives were divided into four main categories, Physical aspects of electric circuits, Energy, Current, and Potential difference (Voltage). Table 4.4 shows the percent correct and the associated question numbers for each of the objectives as well as for the four main categories. Overall, students found objective 8 questions the easiest and objective 9 questions the most difficult. Objective 8 deals with current conservation and objective 9 deals with the microscopic aspects of electric circuits — the why and how of current. Students did better on the questions dealing with the physical aspects of electric circuits especially resistance and approximately the same on questions dealing with energy, current and voltage. An examination of the distracters of the test revealed that on average 18% of the students cannot identify a short in a circuit and/or determine what affect the short has on the circuit, 11% do not know where the contacts are on a light bulb, 6.5% have trouble identifying a complete

Table 4.4: Student performance for each objective for DIRECT version 1.0

	Question Numbers	Objective Number	Percent Correct
Physical aspects of DC electric circuits	4, 5, 9, 10, 13, 14, 18, 19, 22, 23, 27	1 - 5	0.56
Energy	2, 3, 12, 21	6 - 7	0.42
Current	1, 8, 11, 17, 20	8 - 9	0.44
Potential difference (Voltage)	6, 7, 15, 16, 24, 25, 28, 29	10 - 11	0.46
Circuit layout	4, 9, 10, 13, 18, 19, 22, 27	1 - 3 and 5	0.55
Short circuit	10, 19, 27	1	0.50
Functional two-endedness and Complete circuit	9, 18	2 and 3	0.54
Short circuit, Functional two-endedness and Complete circuit	27	1, 2, and 3	0.68
Resistance	5, 14, 23	4	0.59
Diagrams	4, 13, 22	5	0.55
Power	2, 12	6	0.37
Energy	3, 21	7	0.47
Current	8, 17	8	0.62
Micro-macro	1, 11, 20	9	0.31
Ohm's law	7, 16, 25	10	0.60
Potential difference	6, 15, 24, 28, 29	11	0.37
Current and Voltage	26	8 and 11	0.45

circuit, and 32% exhibit current/voltage confusion. It should be noted that some of the values just reported are not above chance.

4.1.3 DIRECT version 1.0 Groups of questions

An examination of the patterns of answers and option choices will be discussed for groups of questions and a few individual questions (see Appendix G for the breakdown of answer choices in a graphical format and Tables 4.1-3 for a numerical format). In some cases, the groups will be the same as those from the factor analysis which will be discussed later in this chapter. Questions 10 and 29 did not fall into any particular grouping and will be discussed first. Question 10 (see Figure 4.7) shows that 53% of the students chose answer C

that bulb C would be the brightest bulb. However, the correct answer is E, that bulbs A and C are the same brightness because bulb B is shorted out. Hidden within this correct answer are potential misconceptions. A student believing that current is consumed and the battery is a constant current source would argue that A and C were equally bright since the battery supplies both with current, I , and B is dimmer because it comes after bulb A which has consumed some of the current. In this case, they may be viewing the bulbs in series or in a series/parallel combination. Those students who said that bulb C only would be the brightest are viewing the circuit with bulbs A and B in either series, in parallel, or in a series/parallel combination. They may also believe that the battery is a constant current source and/or current is consumed. There are a number of combinations of these circuit views and beliefs that will result in the student choosing bulb C.

10) Compare the brightness of bulbs A and B in circuit 1 with the brightness of bulb C in circuit 2. Which bulb or bulbs are the brightest?

(A) A
 (B) B
 (C) C
 (D) A = B
 (E) A = C

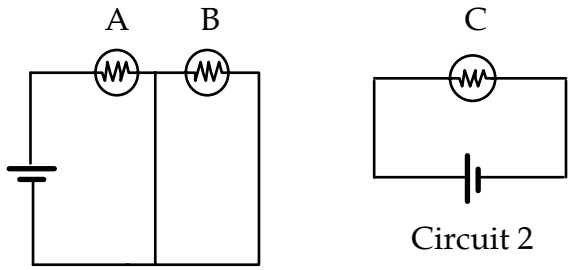

Circuit 1

Circuit 2

Figure 4.7: Question 10 from DIRECT version 1.0

29) What happens to the brightness of bulbs A and B when the switch is closed?

(A) A stays the same, B dims
 (B) A brighter, B dims
 (C) A and B increase
 (D) A and B decrease
 (E) A and B remain the same

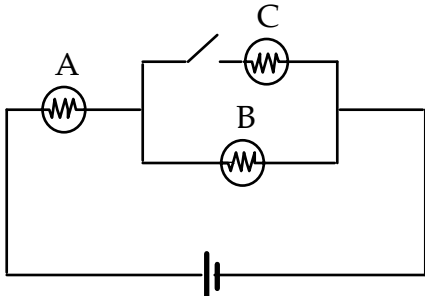

Figure 4.8: Question 29 from DIRECT version 1.0

Question 29 (see Figure 4.8) is initially just a series circuit containing bulbs A and B. When the switch is closed, the circuit becomes a series/parallel combination, bulbs B and C are in parallel and this combination is in series with bulb A. To answer this question correctly, students must understand that adding a resistor in parallel with another lowers the overall resistance, thus, raising the current through the circuit. As a result, bulb A will become brighter while bulb B will become dimmer. Although the current increases, bulb B must now share the current with bulb C so bulb B receives less than it did when in series alone with bulb A. Thirty-one percent of the students were able to arrive at the correct answer. An equal number chose option A, that bulb A would stay the same and bulb B would become dimmer. To arrive at this answer, students might assume either that the battery is a constant current source or that bulb A is unaffected because the change occurs after bulb A (sequential reasoning). To some extent, local reasoning may be hidden in this answer as well. Local reasoning assumes that the current will split evenly at every junction regardless of the resistance that may be contained in each branch. In this case, bulbs B and C would receive the same current since their resistance is the same. However, if bulb C were to have twice the

resistance of bulb B, then the current would not split evenly, although someone using local reasoning would contend that it does.

Questions 6, 15, 17, 19, 24, and 28 probe students' ability to differentiate between current and voltage. Errors on these questions reveal that students believe current and voltage always occur together, current is the cause for voltage, and if one increases, the other also increases.

Questions 4, 9, 13, 18, 22, and 27 deal with students' understanding of the physical layout of the circuit and the interpretation of circuit diagrams. Three questions, 4, 13, and 22, ask students to translate between three descriptions of circuits: verbal, "realistic", and schematic. The results are shown in Table 4.5.

Table 4.5: Students' ability to translate between three descriptions of circuits

43%	Students were able to translate a written description of a parallel circuit into the two correct schematics.
30%	Students were able to identify the more typical form of the parallel circuit.
90%	Students were able to go from a "realistic" representation of a circuit to the schematic circuit.
32%	Students were able to go from the schematic version to a "realistic" representation of the circuit. ¹

Questions 9, 18 and 27 examine students' ability to identify a complete circuit and the functional two-endedness of circuit elements as well as shorts. Questions 9 and 27 consist of a "realistic" representation of a battery and a light bulb. Eighty percent of the students were able

¹This is most likely due to the fact that students were drawn to option E. Forty-four percent selected this option which contains the correct arrangement plus circuit D. Circuit D has a similar arrangement to circuit C, but the bottom two bulbs are shorted out. Thus, it does not match the schematic.

to identify the complete circuits and the need for two contacts from the battery in question 9. Sixty-nine percent were able to identify the complete circuits and the need for two contacts from the battery and the correct contacts on the bulb in question 27. Fifteen percent of those answering question 27 identified the complete circuit but where the bulb contacts were located was incorrect resulting in the shorting out of the bulb. In question 18, 28% were able to identify the working complete circuit, another 68% included a complete circuit which shorted out the bulb and so was non-working.

To summarize, students were able to translate from a “realistic” representation of a circuit to the schematic but had more difficulty in identifying the correct schematic from a written description of the circuit or in identifying the correct “realistic” representation of a circuit from the given schematic. In general, students could identify a complete circuit. The difficulty arose when students were asked to determine whether the circuit worked or not. They included circuits that contained shorted out elements as working. The shorts took the form of an additional wire connected in parallel across an element or the contacts from the battery being connected to the same point on the bulb. Students appeared to have a deficiency in their declarative knowledge² about light bulbs. They did not know where to make the appropriate contacts.

Questions 2, 21, 25, and 26 have very similar circuits. The questions varied but the errors associated with these questions revealed that students believe the battery is a constant current source and that current is consumed in the circuit. These results are a replication of findings made by other researchers.

Questions 3, 7, 12, and 16 contain batteries that are in series and/or parallel. Students found these problems somewhat difficult. The average difficulty on this group of problems is 43% which means that over fifty percent of the students were getting them wrong, especially

²Farnham-Diggory (1992) define declarative knowledge as “knowledge that can be ‘declared’ in so many words. It is the knowledge acquired from reading textbooks, listening to lectures and conversations, and from other forms of verbal exchange” (p. 85).

question 12. Errors were most often associated with what happened with the two batteries in parallel. Some students used battery superposition which says that if one battery lights the bulb, then two, regardless of the arrangement, will make the bulb twice as bright. Students may also have been trying to apply the rules for equivalent resistors or capacitors to the battery arrangements. From the interviews, some students believed that each battery in the parallel arrangement was putting out a current, I , so that at the junction the current would be $2I$, which illustrates the battery as a constant current source and local reasoning difficulties.

The concept of resistance is covered in questions 5, 14, and 23. Question 5 tests whether students understand or recall that there is a difference in the equivalent resistance between two resistors in series and two resistors in parallel. Nearly 80% of the students were successful with this question. Question 14 explores students understanding of equivalent resistance in a series/parallel combination. The initial circuit is two resistors in series and has an equivalent resistance of $2R$. When the switch is closed, the circuit becomes a series/parallel combination which has a resistance of $\frac{3}{2}R$. Fifty-seven percent answered this question correctly but 30% used what may be called resistive superposition. Adding another resistor, regardless of how it is connected, increases the overall resistance and decreases the current. Question 23 examines students' awareness that a bulb or resistor always has some resistance. This particular item has been questioned by some of the instructors giving the exam. It is true that a light bulb's resistance varies with temperature. As the bulb warms, the resistance increases, and vice versa. The question's intent is that there is not sufficient time to change the filament's temperature so that the resistance stays the same. If students do not interpret the question in this manner then answer B should also be counted as correct. An examination of the responses shows that only 11% chose option B. 41% chose option C which says the resistance stays the same while 39% chose option D which says the resistance goes to zero. Option D results from students reasoning that since the current is zero, the resistance is zero,

since resistance is the hindrance or resistance to the current. You must have one to have the other.

Various aspects of current are dealt with in questions 1, 8, 11, 17, and 20. Questions 1, 11, and 20 deal with the microscopic aspects of current which are not usually presented in a traditional introductory course. As discussed in Chapter 2, current is often confused with energy and voltage. This can be seen in student responses to questions 1, 8, 11 and 17. Properties of energy are given to current in questions 1, 8, and 11 while current and voltage are confused in question 17. In question 20, 63% of the students attribute the cause for electric field produced in the bulb's filament to current, which is incorrect. The electric field supplies the force which causes the charges to accelerate, resulting in a current.

4.1.4 DIRECT version 1.0 Group comparisons

t-tests were performed on various groups of students who participated in this study. Groups were considered significantly different if the level of significance or *p*-value was at or below .05; above .05, the groups were considered the same. This gives a 95% level of confidence that there is truly a difference. All *t*-tests assume a one-tail test of significant so that the superiority of one group over the other can be determined. Students' raw scores were used in these calculations, so that a score of 29 is equivalent to 100%. The results from comparisons of students taking DIRECT version 1.0 will now be presented.

There were significant differences in the means for the university ($M = 15$) and high school groups ($M = 12$), $t(1008) = 11, p < 3.8 \times 10^{-28}$, with university students outperforming high school students. Significant differences were found between males and females with males outperforming females at all levels, overall, university, and high school (see Table 4.6). There were no significant differences between calculus-based ($M = 16$) and algebra-based ($M = 15$) university students, $t(191) = -1.6, p < .06$. However, there was a small group of calculus-based students who used a new textbook by Chabay and Sherwood which did discuss the microscopic aspects of circuit phenomena. There were significant differences found between

these students ($M = 18$) and regular calculus-based students ($M = 15$), $t(76) = -3.8, p < .0001$, as well as the university group ($M = 15$) as a whole (algebra and calculus-based combined), $t(44) = -4.2, p < 6.1 \times 10^{-5}$. Those students using the Chabay and Sherwood textbook outperformed both groups. No significant differences were found between the Advanced Placement or Honors high school students ($M = 12$) and those high school students taking a regular physics class ($M = 13$), $t(342) = -.89, p < .19$.

Table 4.6: t -test results for each sample taking DIRECT version 1.0

Group	Mean and standard deviation for Males	Mean and standard deviation for Females	Degrees of freedom	t	p -value
Overall	14 ± 4.7	12 ± 3.4	600	8.5	7.4×10^{-17}
University	16 ± 5.0	12 ± 3.7	123	5.2	4.6×10^{-7}
High school	13 ± 4.2	11 ± 3.3	425	5.7	1.1×10^{-8}

4.2 Interview Analysis

Interviews were conducted with two groups of students in Raleigh, NC. One group consisting of 17 students enrolled in a second semester introductory physics course at North Carolina State University. The second group consisting of 11 Advanced Placement high school students at Enloe High School who were enrolled in introductory physics. As discussed in Chapter 3, students were selected based on their responses to DIRECT version 1.0. Interviews covered three aspects of the exam, symbols used, student definitions of terms used on the exam, and the 10 selected questions.

4.2.1 Symbols used on DIRECT 1.0

The table of symbols used on the exam were the focus of the first part of the interview. Students were asked to identify each symbol and to relate certain properties associated with

each symbol. For example, “Given the battery symbol below, what does the long line indicate and what does the short line indicate?” (see Figure 4.9) The results are shown in Table 4.7.

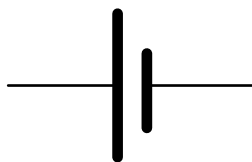

Figure 4.9: Battery symbol

Table 4.7: Results from interviews regarding symbols used on exam

91%	Understood the symbols used on the exam
68%	Knew that a light bulb had two connections. ³
32%	Believed that there was only one connection which was located at the bottom of the bulb.

The symbol of a light bulb in a socket presented the students with a great deal of difficulty compared to the other symbols. Sockets are not typically taught and so the symbol is not familiar to the students. There is also not a standard way to represent a socket. Thus, even if students had previously seen a representation of a socket, the one used on the exam may not be similar enough for them to recognize it. In version 1.1, this symbol was removed and re-drawn with just a battery and a light bulb.

4.2.2 Student definitions of terms

³However, one of the students believed that both connections were to the bottom of the bulb and another was unsure of where the connections actually were.

In order not to assign the researcher's meaning of terms onto students' meaning of terms, students were asked for the following definitions: charge, current, voltage, potential difference, resistance, energy and power. Table 4.8 shows the various classifications of definitions for each term and the percentage of students using that definition. The numbers that have been highlighted indicate the most often used definition. The numbers in italics indicate the second most often used definitions. The total percentage of students using a definition may be greater than 100 since some students on occasion used more than one classification in their definition. Consider the following high school student's definition of voltage which was coded as 1 for potential difference and 2 for pressure,

That one's harder. It's the potential difference between the places the energy is going. If you make an analogy to water systems where charge is the amount of water, current would be the speed of the water and voltage would be the pressure.

This particular student was the only one to refer to the water analogy which is sometimes introduced to aid student understanding of circuits concepts.

The classifications used to code the students' definitions were examined for their accuracy. Some of the classifications were found to be incorrect based on the physics. These are italicized in Table 4.8. For example, students defined current as a flow of energy. This is incorrect. It is the flow of charges. Tables 4.9-11 were constructed by pairing the students various definitions of terms and looking for patterns of incorrect definitions. In some cases, one term is defined correctly and the other is not. Table 4.9 presents how students define charge, voltage, resistance and energy in relation to current. Table 4.10 shows how students relate the terms power and energy. Table 4.11 illustrates how students relate potential difference and voltage. Additional comments will be made about these definitions with respect to student misconceptions later in this chapter.

Table 4.8: Classifications used with student definitions of terms on DIRECT version 1.0

Code	Charge	Current	Voltage	Potential Difference	Resistance	Energy	Power
1	Electron or proton (7.1)	Flow of particles (7.1)	Potential difference (29)	Difference in potential (36)	Reduces flow (25)	Work (39)	Rate of work (39)
2	Positive or negative (21)	Flow of energy (11)	Pressure (7.1)	Difference in charge (11)	Ohm's law (3.6)	Unit (3.6)	Rate of energy (39)
3	Unit (7.1)	Power (3.6)	Ohm's law (11)	Voltage (29)	Unit (3.6)	Equated with current (3.6)	Equation (14)
4	Accumulation or deficit of particles (29)	Ohm's law (3.6)	Power (11)	Power (7.1)	Don't know (0)	Don't know (11)	Don't know (3.6)
5	Energy (21)	Electric field (3.6)	Energy (11)	Energy (3.6)	Resists flow (32)	Power (11)	Unit (3.6)
6	Don't know (7.1)	Unit (3.6)	Don't know (0)	Ohm's law (0)	Friction (11)	Stored voltage or Stored in Capacitor or Inductor (11)	Force behind current (7.1)
7	Power (3.6)	Don't know (3.6)	Unit (3.6)	Force to push charge or pressure (7.1)	Work (3.6)	Charge flow as transfer of energy (7.1)	Power equated with energy (3.6)
8	Moving particle (7.1)		Charge difference (14)	Don't know (7.1)	Resistor (3.6)	Something battery supplies (7.1)	No data (3.6)
9			Current causes voltage (7.1)		Energy reduced (18)	No data (7.1)	
10			Intensity of current (7.1)		Consumes current (7.1)		
11			Push on charge (7.1)		Dead point in circuit (3.6)		

Table 4.9: Comparison of students' definitions of current with the other terms

Current	Charge	Voltage	Resistance	Energy
Flow of particles	Energy Power Moving particles	Power Energy Charge difference Current cause of voltage Intensity of current	Dead point and energy reduced Consumes current	Equated with current Power Charge flow as transfer of energy
Flow of energy	Energy Positive or negative	Power Pressure Potential difference Intensity of current	Reduces flow Friction Consumes current	Work Something the battery supplies
Electric field	Positive or negative	Push on charge	Reduces flow	Work
Power			Ohm's law	
Unit			Work	Charge flow as transfer of energy

Table 4.10: Comparison of students' definitions of energy and power

Energy	Power
Power	Force behind the current Rate of energy and unit Equation
Stored voltage or Stored in a capacitor or inductor	Force behind the current
Charge flow as transfer of energy	Rate of work or energy
Something the battery supplies	Energy

Table 4.11: Comparison of students' definitions of potential difference and voltage

Potential Difference	Voltage
Difference in potential	Power Power and energy
Difference in charge	Potential difference Charge difference
Voltage	Charge difference Current causes voltage
Power	Ohm's law Energy
Energy	Potential difference
Don't know	Energy Intensity of current

4.2.3 Analysis of student responses to the 10 selected questions

This data serves two purposes. The first is to uncover students' reasoning behind their answer choices. The second is to provide evidence that the test is valid. This is accessed in terms of whether students are indeed choosing answers based on certain misconceptions that the answer choices illicit. For example, on question 8 (see Figure 4.10), choosing either point 1 or point 2 should indicate that students' believe that current is consumed in the circuit. The difference between the two answers is simply which current convention the student is using. If the student were using conventional current (which is the flow of positive charges), the student would say that point 1 is larger. If the student is using electron flow, then point 2 would be larger. Based on the literature, option C could contain a misconception as well. Students may use the clashing currents model of current flow. Although the percentage of students at this level should be very low, individual interviews would determine if there are any students still holding this view of current. An examination of students' reasoning behind their answers for each question will be addressed first, followed by the validity evidence.

8) Compare the current at point 1 with the current at point 2. Which point has the larger current?

- (A) Point 1
- (B) Point 2
- (C) Neither, they are the same

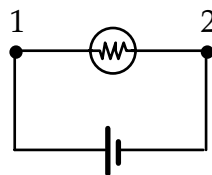

Figure 4.10: Question 8 from DIRECT version 1.0

3) Consider the circuits shown below. Which circuit or circuits have the greatest energy delivered to it per second?

- (A) Circuit 1
- (B) Circuit 2
- (C) Circuit 3
- (D) Circuit 1 = Circuit 2
- (E) Circuit 2 = Circuit 3

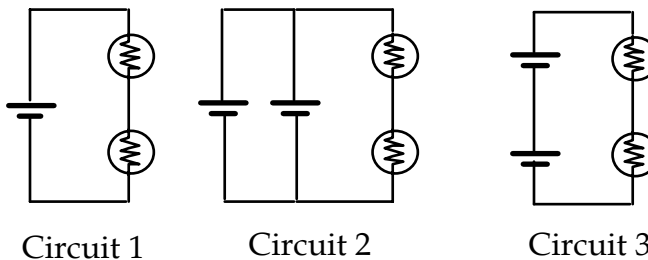

Figure 4.11: Question 3 from DIRECT version 1.0

Question 3 (see Figure 4.11) deals in part with students' ability to reason about circuits containing multiple batteries. Generally, students see only a single battery or perhaps two batteries in series, rarely do they see two batteries connected in parallel. Thirty-nine percent of the students were able to arrive at the correct answer with the correct reasoning. One student gave the correct answer choice but there were errors in the reasoning. Twenty-five chose either option B or option E. Students arrived at option B either by reasoning that each battery supplies a current, I , so that at the junction the current joins to give $2I$ or they calculated the

equivalent voltage using the equation for capacitors in parallel. Here is an example from a high school student:

Well, I think for this one I figured out I don't know how to do these two battery things but I figured it as probably circuit 2 because this one only has one battery [referring to circuit 1]. This has two batteries [referring to circuit 2] so I thought the positive stuff would come up and they'd join right here and there would be twice as much voltage coming through here. Then for this one [referring to circuit 3] I figured that you'd get one battery's worth of voltage coming through here and then it would go into the negative there and this positive would just go to that so I figured these two [referring to circuits 1 and 3] would be pretty much the same and this one [referring to circuit 2] would have the most energy per second.

Their reasoning behind option E was battery superposition, two batteries provide more current than one battery regardless of the battery arrangement. Here is an example from a student taking a traditional, calculus-based course:

I think I would put E because the batteries are providing the energy so since they both have two two [*sic*] batteries. I didn't think that it would matter whether they were in parallel or series because they're gonna add a certain amount of voltage and when the parallel batteries link up it's gonna be equivalent to whatever voltage is added when they are in series and then the light bulbs since they are just two in series, that's the same for all three pictures.

Question 8 (refer to Figure 4.10) is the most straightforward of the questions in terms of student reasoning. They either conserved current or they did not. The majority did conserve current while 8 of the 28 students did not. Fifteen of the 28 students asked were using conventional current while 6 of the 28 students were using electron flow. None of the students interviewed were found to use the clashing currents model of current. This result is not surprising given that Shipstone (1984a) reports that less than 10% use this model by age 17.

Question 10 (see Figure 4.7) elicited the greatest number and widest variety of misconceptions from the students. Of the 13 students who gave the correct multiple choice response, only 5 gave the correct reasoning that bulb B was shorted out. Students can arrive at

the correct multiple choice response via misconceptions. Consider the following high school student's answer:

I don't know. I'd say A would equal C just because they're the first light bulbs that the voltage comes to when it goes around and when it gets here, it drops so the voltage would stay the same. Then it splits here but it would be less voltage going to B so I'll say that A and C would be the same voltage.

This student assumes the battery as a constant current source when he says that A and C are the first bulbs. He uses local reasoning when he refers to the "voltage" splitting at the junction and is confusing voltage with current. Current is a flow. Voltage is static. However, the multiple choice answer of $A = C$ is correct.

As you can see in Figure 4.7, circuit 1 contains a shorting wire between bulbs A and B. Students either viewed circuit 1 as two bulbs in series or two bulbs in parallel. This type of error was classified in part as a topological error (refer back to Chapter 2.7.2). Additional misconceptions such as current consumed, local reasoning, voltage/current confusion, battery as constant current source, resistive superposition, or resistive equivalence were also found to occur. Through using various combinations of these misconceptions, students either chose option 3 (14 of 28) or option 5 (13 of 28).

15) What happens to the potential difference between points 1 and 2 if bulb A is removed?

(A) Increases
(B) Decreases
(C) Stays the same

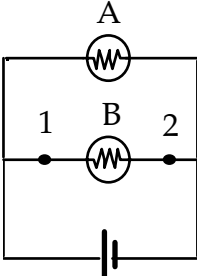

The diagram shows a circuit with a battery at the bottom. A wire goes up from the battery, then left, then up to bulb A. From bulb A, the wire goes right to a junction. From this junction, one wire goes down to bulb B, and another wire goes down to the battery. From bulb B, the wire goes left to point 1, then left to the battery. Point 2 is on the wire between bulb B and the battery.

Figure 4.12: Question 15 from DIRECT version 1.0

Question 15 (see Figure 4.12) inquires about students' understanding of potential difference. Two students initially misinterpreted the question thinking that bulb A was removed and replaced by a wire. As with question 10, some students (5 of 16) arrived at the correct answer via misconceptions. Eleven students answered this question correctly. Twenty-five percent of the students chose option A while the other 18% chose option B. In choosing option A, students confused voltage and current and believed the battery was a constant current source. Consider the following from an honors calculus-based university student who used the Chabay and Sherwood text:

Well, if A is removed, then more current flows through B so the potential difference would be greater. It increases, [option] A.

This student assumes that the current has not changed (battery constant current source) and has equated the increase in current directly with an increase in the voltage (current/voltage confusion). Here is another example from a university student in the traditional calculus-based course:

If you take A out or one of the resistors out then you've got one resistor in series instead of two in parallel so your resistance is going to increase which means your potential is going to decrease. [option B]

This student is correct when he says that the resistance is going to increase. However, he incorrectly assumes that the current stays the same when he concludes that the potential must decrease.

16) Compare the brightness of bulb A in circuit 1 with bulb A in circuit 2. Which bulb is dimmer?

(A) Bulb A in circuit 1
 (B) Bulb A in circuit 2
 (C) Neither, they are the same

Circuit 1 Circuit 2

Figure 4.13: Question 16 from DIRECT version 1.0

Question 16 (see Figure 4.13) was another question dealing with multiple batteries. This time students had to consider the difference between a single battery and two batteries in parallel with the additional complication that the resistance also changed. Nine students got this question correct. Twelve students chose option A. During the interviews it became clear that many of these students used battery superposition as part of their reasoning. They said that two batteries would result in bulb A in circuit 2 being brighter than bulb A in circuit 1. This is an interesting contrast to question 3. In question 3, those choosing the parallel battery arrangement as having more energy reasoned via battery as a constant current source and local reasoning while in question 16 they used battery superposition. In question 3, the only difference between circuits 1 and 2 was the number and arrangement of the batteries. In question 16, both the number and the arrangement of the batteries and resistors changed. These results may be related to those obtained by Sebastià (see Table 2.3 and Figure 2.9). Recall that he found that the number of correct answers increased across level for question 21 but that the number of correct answers remained constant on question 22. He suggested that the improvement on question 21 may be due to additional declarative knowledge while the consistency of answers on question 22 may be more indicative of student reasoning patterns.

Question 20 (refer back to Figure 4.2) itself was given to me by Bruce Sherwood, a professor at Carnegie Mellon University and co-author of a text presenting an alternative approach to electricity (personal communication, January 25, 1995). The open-ended version of the test did not yield any usable distracters. Thus, all the distracters were developed by the researcher. In interviewing the university students on this question, they were asked to state why they preferred their choice over the other alternatives. Generally, the results were inconclusive (1 of the 17 university students simply guessed). The same procedure was begun with the high school students but abandoned. The high school students were simply not able to verbalize their reasoning to this question. This is most likely due to their unfamiliarity with the microscopic view of circuit phenomena. It was discovered that 5 of the 11 high school students interviewed simply made a guess. In some cases students' reasoning was based on the reasons given in the distracters, 12 students have the cause and the effect of current backwards. They believe that the current is the cause of the electric field. Two students believed that the electric field is always zero inside a conducting metal, even though, this is true only under electrostatic conditions.

Some will argue that without instruction on the underlying processes of electric circuits, students will not be able to answer this question correctly and should not be penalized. Part of the point of having this type of question on the exam is to bring out the point that students do *not* understand the microscopic aspects and that this ill prepares them for understanding the macroscopic aspects of circuits. To counter this argument, there were five students who were taking a special honors course that used the Chabay and Sherwood text. These students were exposed to the microscopic aspects of circuits, including the fact that "charges on the surface of wires make the electric fields inside the wires" (1995b, p. 232). The bulb filament is just another type of wire or resistor which is also mentioned in the text on page 217. One would assume that these students should chose answer D, which says that there are charges on the surface of the filament. However, the majority of the students, 4 out of 5, chose

C which says that the circuit is complete and a current is flowing. It may be that these students were thrown off by the question since it inquired about an electric field inside the bulb filament.

22) Which realistic circuit(s) represent(s) the schematic diagram shown below?

(A) B
 (B) C
 (C) D
 (D) A and B
 (E) C and D

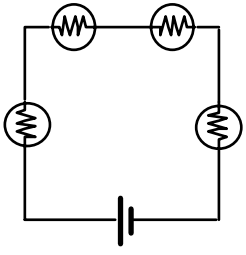

A

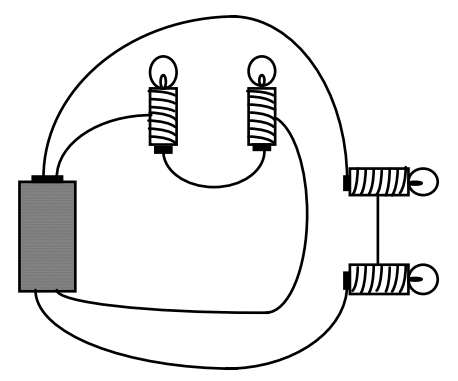

B

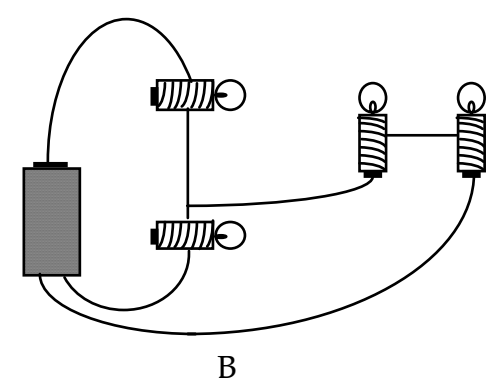

C

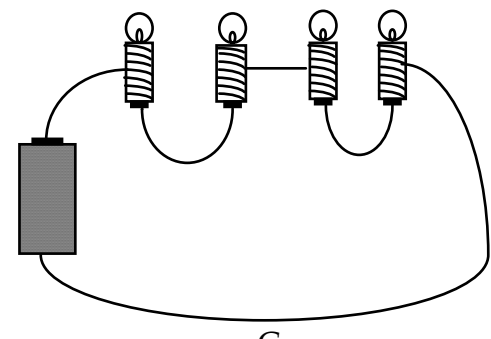

D

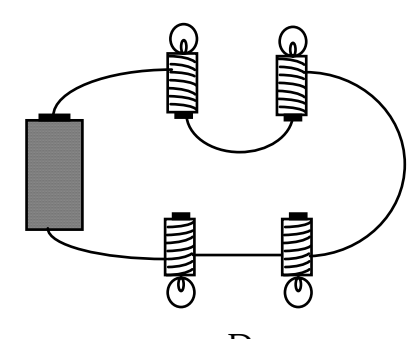
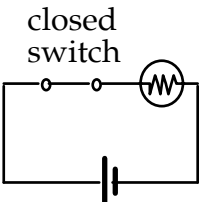

Figure 4.14: Question 22 from DIRECT version 1.0

Question 22 (see Figure 4.14) was selected because students may have had a clear understanding of the concept but may have made a mistake on their Opscan sheet. Look at the question shown in Figure 4.14 carefully. The order of the multiple choice options is not consistent with the circuit labels. Answer A indicates a selection of circuit B while answer C indicates a selection of circuit D. Students who wanted to answer circuit C may have mistakenly selected Answer C on the Opscan form. Along with the reasoning behind their answer choice, students were asked whether this may have happened. Eighty-two percent indicated that this could have happened. The multiple-choice exam results for those students who were interviewed indicated that only 32% of the students answered this question correctly. At the interview, this value increased to 75%. The remainder of the students either chose answer D (2 of 28) or answer E (5 of 28). These choices resulted from a lack of understanding of where the contacts of the light bulb were located. Circuit D has the correct bulb arrangement except that the bottom two bulbs of the configuration are shorted out.

23) Immediately after the switch is opened, what happens to the resistance of the bulb?

(A) The resistance increases.
(B) The resistance decreases.
(C) The resistance stays the same.
(D) The resistance goes to zero.



The diagram shows a simple rectangular circuit. At the bottom is a battery symbol. On the top horizontal wire, there is a switch symbol with two small circles representing contacts, and the text "closed switch" is written above it. On the right vertical wire, there is a light bulb symbol (a circle with a zigzag line inside). The circuit is closed.

Figure 4.15: Question 23 from DIRECT version 1.0

Question 23 (see Figure 4.15) deals with resistance. Fifty percent of the students answered this question correctly. Nine of the 28 students reasoned that since there was not any current, then there was nothing for the resistor to resist. Reasoning this way, they either chose that the resistance would decrease (5 of 28) or that the resistance would go to zero (6 of 28). Only 2 students initially reasoned correctly that the resistance would decrease because the temperature of the bulb would decrease. One changed to answer C after discussions about the words “Immediately after” and the other one stayed with answer B.

Question 28 (refer to Figure 4.3) dealt with students’ understanding of potential difference or voltage. Only 32% of the students answered this question correctly. The remainder reasoned that since there was no current then there was no voltage. This form of reasoning illustrates students confusion with current and voltage. In this case, they must occur together. It is not clear if they believe that current causes the voltage or merely that they must occur together. It is also an indication that they do not fully understand how the elements of the circuit are affected when the circuit is open.

Fifty percent of the students interviewed selected option A on question 29 (refer to Figure 4.8). Only 25% of the students answered this question correctly. Those that chose answer A used a combination of battery as a constant current source and sequential reasoning. Local reasoning is also a possibility. However, since the resistance of bulbs B and C are the same, it is unclear if students are indeed using it. Students reasoned that bulb A would not change since the switch closure came after it. They must also be assuming that the current does not change when bulb C is added to the circuit. Here is an example from a high school student:

A, A stays the same and B dims because your current isn’t diverted until you hit the CB connection and here it won’t divert until the switch is closed and so there won’t be as much current going through B so it will dim.

Table 4.12: Classifications used to code student interviews and their frequencies

	Code	Description	Frequency
1	Battery superposition	1 battery — bulb shines x bright 2 batteries, regardless of arrangement — bulb shines 2x bright	17
2	Battery as a constant current source	Battery supplies same amount of current to each circuit regardless of the circuit's arrangement	40
3	Complete circuit	Unable to identify a complete circuit — closed loop	2
4	Contacts	Unable to identify the two contact on the light bulb	5
6	Current consumed	Current value decreases as you move through circuit elements until you return to the battery where there is no more current left	14
7	Direct route	Battery is the only source of charge so only those elements with a direct contact to the battery will light	1
8	$E = 0$ inside	Electric field inside a conductor is always zero	2
9	Guessed		10
10	I causes E	Current is the cause for the electric field inside the wires of the circuit	12
11	Incomplete evidence	Unable to determine student's reasoning	10
12	Local	Current splits evenly at every junction regardless of the resistance of each branch	25
13	Other	Student's reasoning did not fall into one of the other categories	9
14	R_{eq}	Student equated the equivalent resistance of a circuit with an individual resistor	3
15	Resistive superposition	1 resistor reduces the current by x 2 resistors reduce the current by 2x regardless of the resistor's arrangement	8
16	Rule application error	Misapplied a rule governing circuits. For example, used the equation for resistor in series when the circuit showed resistors in parallel	2
17	Sequential	Only changes before an element will affect that element	16
18	Term confusion I/R	Resistance viewed as being caused by the current. A resistor resists the current so a current must flow for there to be any resistance	9
19	Term confusion I/V	Voltage viewed as a property of current. Current is the cause of the voltage. Voltage and current always occur together	29
20	Topology	All resistors lined up in series are in series whether there is a junction or not. All resistors lined up geometrically in parallel are in parallel even if a battery is contained within a branch	24
21	$V=C_{eq}$	Voltage calculated using equations for equivalent capacitance	2
22	$V=R_{eq}$	Voltage calculated using equations for equivalent resistance	3
5	Correct		108

Table 4.12 shows the various classifications used to code students' responses to the questions. Also shown in the Table 4.12 are the total number of times each misconception was used. As previously mentioned, students often used more than one misconception in stating their reasoning for their answer choices to each of the questions. As a result, there were 351 classifications with 71 multiple classifications. Examining Table 4.12 reveals that students used Battery as a constant current source most often.

The twenty eight students answered the 10 questions correctly 108 times or 39% of the time. Figures 4.16-18 show how the different groups of students performed in terms of providing correct explanations on the interview questions. The raw scores were used in these calculations so that a score of 10 is equivalent to 100%. t -tests show significant differences in the mean scores for males ($M = 5$) and females ($M = 2$), $t(24) = -3.6, p < .0007$, with males outscoring females. The same was found for university males ($M = 5$) and females ($M = 3$), $t(13) = -2.5, p < .01$. There were significant differences between the university ($M = 4$) and high school scores ($M = 3$), $t(24) = 1.7, p < .05$. However, there were no significant differences between the high school males ($M = 5$) and females scores ($M = 2$), $t(4) = -1.8, p < .07$. Students guessed 4% of the time with high school students and females guessing most often. Student reasoning was indeterminable 4% of the time. The high school students had more difficulty expressing their reasoning and accounted for 90% of this classification. The remaining 54% of the time, the students reasoned using misconceptions.

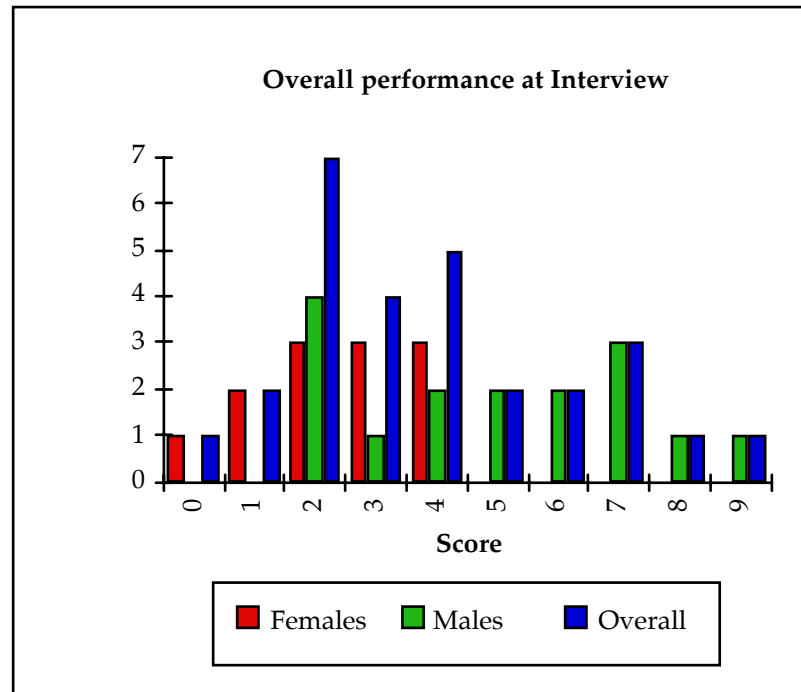

Figure 4.16: Number of overall students providing correct reasoning at Interview ($N = 28$ with 12 females and 16 males)

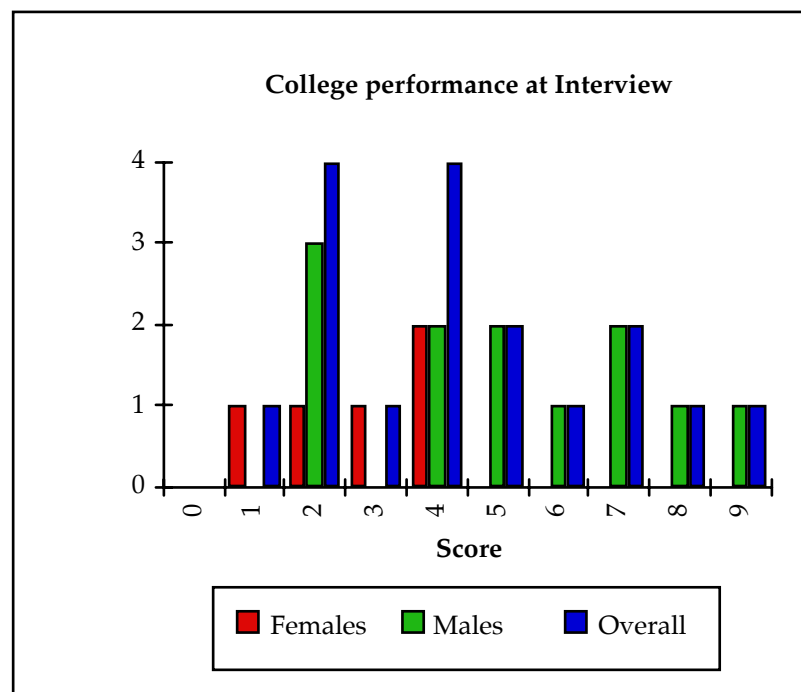

Figure 4.17: Number of university students providing correct reasoning at Interview ($N = 17$ with 5 females and 12 males)

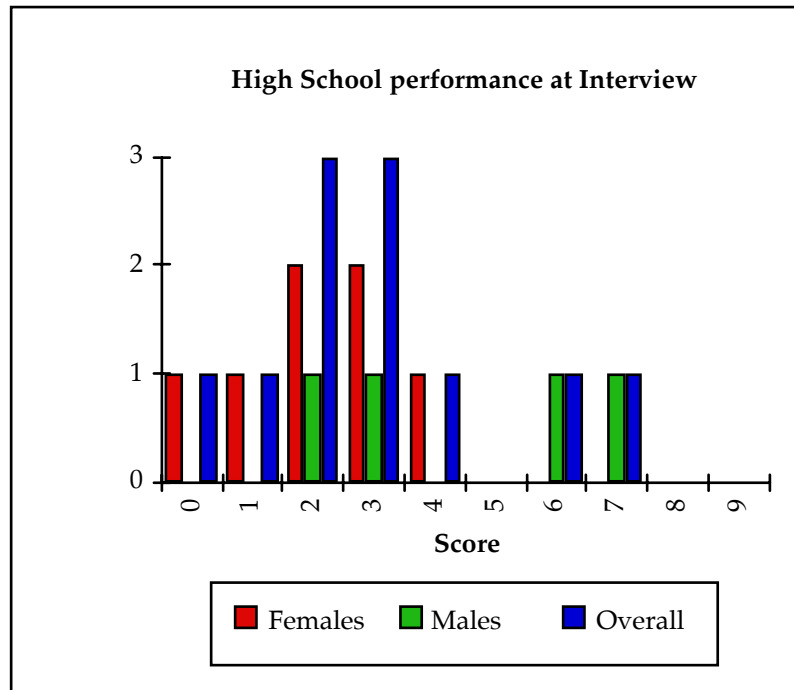

Figure 4.18: Number of high school students providing correct reasoning at Interview ($N = 11$ with 7 females and 4 males)

Table 4.13 shows the number of questions each interviewed student answered correctly, the number of misconceptions they used to answer the questions, and whether or not they are dominated by misconceptions. The number of misconceptions can be higher than the number of missed questions since students often used more than one misconception in answering the questions. The criterion used to determine if a student was dominated by misconceptions was the following: If the number of misconceptions used by the student is equal to or greater than twice the number correct, then the student is dominated by misconceptions. This criterion classifies students who use misconceptions at least 50% of the time as dominated by misconceptions. Thus, students would answer correctly only 50% of the time which is far from showing an acceptable understanding of the material.

t -tests showed that there were significant differences between the number of misconceptions used by males ($M = 6$) and females ($M = 11$), $t(25) = 3.9$, $p < .0003$, with females using more than males. There was a similar finding for university males ($M = 6$) and females ($M = 11$), $t(11) = 3.6$, $p < .002$. However, there were no significant differences found for either the high school males ($M = 6$) and females ($M = 10$), $t(4) = 1.4$, $p < .12$, or between university ($M = 8$) and high school students ($M = 9$), $t(23) = -.73$, $p < .24$.

Table 4.13: Summary of Interview Results

Gender	Course/Level	Number correct	Number of misconceptions	Dominated by misconception?
Female	Honors calculus/University	4	9	yes
Female	Honors calculus/University	2	12	yes
Female	Calculus/University	3	9	yes
Female	Calculus/University	1	15	yes
Female	Calculus/University	4	12	yes
Male	Honors calculus/University	9	1	no
Male	Honors calculus/University	7	5	no
Male	Honors calculus/University	6	3	no
Male	Calculus/University	4	7	no
Male	Calculus/University	5	5	no
Male	Calculus/University	8	2	no
Male	Calculus/University	4	7	no
Male	Calculus/University	5	5	no
Male	Calculus/University	7	3	no
Male	Algebra/University	2	11	yes
Male	Algebra/University	2	10	yes
Male	Algebra/University	2	12	yes
Female	AP/high school	4	7	no
Female	AP/high school	1	10	yes
Female	AP/high school	2	7	yes
Female	AP/high school	3	11	yes
Female	AP/high school	3	10	yes
Female	AP/high school	0	13	yes
Female	AP/high school	2	12	yes
Male	AP/high school	3	10	yes
Male	AP/high school	7	2	no
Male	AP/high school	2	11	yes
Male	AP/high school	6	2	no

Table 4.14: Misconceptions summary for each student and question

M/F	Course/Level	3	8	10	15	16	20	22	23	28	29
F	Honors Calculus/ University	2 12	5 5		2	1	10 5	5	19	2 12 17	
F	Honors Calculus/ University	2 12	5 20		2	1	13 4 20	5	19	2 12 17	
F	Calculus/ University	21	5 15 20		2	5	9 5	18	19	2 12 17	
F	Calculus/ University	1	6 2 6 19 20		2 19	1 6	10 7	5	19	2 12	
F	Calculus/ University	5	5 2 6 19 20		2 19	22	8 5	5	19	2 12 17	
M	Honors Calculus/ University	5	5 5		5	5	5 5	5	19	5	
M	Honors Calculus/ University	5	5 2 12 20		5	5	13 5	16	5	5	
M	Honors Calculus/ University	5	5 13		5	1	11 5	18	5	5	
M	Calculus/ University	5	5 14 20		2 14	9	13 5	5	19	3	
M	Calculus/ University	1	5 20		19	5	10 5	5	19	5	
M	Calculus/ University	5	5 5		5	5	13 5	13	5	5	
M	Calculus/ University	1	5 2 20		2	5	10 5	5	19	15	
M	Calculus/ University	5	5 20		5	1	10 5	5	19	15	
M	Calculus/ University	5	5 5		5	5	10 5	5	19	14	
M	Algebra/ University	2 12	6 2 19 20		5	1	10 5	18	19	3	
M	Algebra/ University	1	5 20		2	22	10 5	18	19	2 12 17	
M	Algebra/ University	1	5 15 20		5	1	10 4 20	18	19	2 12 17	
F	AP/high school	11	6 6 15 20		5	11	9 5	5	5	2 12 17	
F	AP/high school	21	6 2 12 20		9	5	11 9	18	19	2 12 17	
F	AP/high school	2 12	6 5		13	1	9 5	18	19	11	
F	AP/high school	2 12	5 15 20		2	22	8 5	5	19	2 12 17	
F	AP/high school	1	5 2 6 20		16	5	11 5	18	19	2 12 17	
F	AP/high school	2 12	6 15 20		17	1	9 4	17	11	2 12 17	
F	AP/high school	5	6 2 12 19 20		11	1	9 4 20	18	5	2 12 17	
M	AP/high school	2 12	5 2 12 19 20		5	1	10 5	13	19	11	
M	AP/high school	5	5 11		5	13	10 5	5	5	5	
M	AP/high school	5	6 2 6 20		19	15	9 4 20	17	5	2 12	
M	AP/high school	2	5 5		11	9	10 5	5	5	5	
	Objective	E	C	P	V	V	C	P	P	V	V
	Dominant misconception	2	6	20	2	1	10	4	18	19	2, 12

E stands for Energy, C for Current, P for Physical aspects of the circuit, and V for Voltage

Table 4.14 shows what misconceptions students used for each of the 10 questions. For the meaning of each code, refer back to Table 4.12. A code of 5 indicates a correct response. It is important to note that 50% of the students used at least one misconception on 8 of the 10 questions. Question 10 elicits the most misconceptions with 75% of the students having used a misconception. Although students tend to use different misconceptions on most of the questions, students do tend to use the same misconception on questions 8 and 28. This may be due to the simplicity of the circuit since the circuit in each case is a static series circuit. By static, it is meant that there are no changes to the circuit. This table also illustrates that the dominant misconception changes with each question. For example, battery as a constant current source is the main misconception associated with questions 3, 15, and 29 while current consumed is for question 8.

Initially, there appears to be no pattern to the students' reasoning on these questions. However, examining the dominant misconception and the global objectives for each question does yield a pattern. The misconceptions associated with each global objective are related with that objective. For example, questions 15, 16, 28 and 29 are associated with the voltage objective. The dominant misconceptions for these questions are battery as a constant current source, term confusion I/V, Local reasoning, and battery superposition. Other than local reasoning, these misconceptions relate to students' understanding of the properties of the battery and what it supplies to the circuit. Similarly, the misconceptions associated with physical aspects of the circuit objective relate to features of the circuit. The misconceptions are topology, contacts, and term confusion I/R. The topological errors students made seem to indicate that they look at the surface features of the circuit. The contact error indicates that students are missing some declarative knowledge about where the contacts are location on a light bulb. Term confusion I/R errors indicate that students do not understand that a resistor (including light bulbs) has an inherent resistance based on its shape and the material from which it is made. One could categorize errors associated with the physical aspects of the

circuits as students not having the declarative knowledge needed to understand the physical nature of the circuit diagram and its associated elements. Thus, although students tend to use different misconceptions for each question presented, they do tend to use misconceptions associated with the global objective of the question.

Students were asked their confidence on their responses to the questions at the interview. Confidence values were 1 for low, 2 for in-between, and 3 for high. Results indicate that the university students ($M = 2.2$) tended to be more confident in their answers than were the high school students ($M = 1.8$), $t(20) = 2.8$, $p < .006$. Similarly, males ($M = 2.3$) were more confident in their responses than were the females ($M = 1.8$), $t(23) = -3.7$, $p < .0006$. For each of the 10 questions, an examination of differences in confidence level was made between those students answering the question correctly and those using the dominant misconception for that particular question. t -test results indicate that there were no significant differences between the two groups on questions 3, 10, 15, 16, 22, 23, 28, and 29 (see Table 4.15). However, on question 8, there was a significant difference with those answering correctly ($M = 2.6$) being more confidence than those who believed that current was consumed ($M = 1.7$), $t(8) = 2.9$, $p < .01$. Question 20 could not be evaluated since only one student answered the question correctly.

Table 4.15: t -test results for each interview question regarding confidence level

Question Number	Mean and standard deviation for those answering correctly	Mean and standard deviation for those using the dominant misconception	Degrees of freedom	t	p -value
3	1.9 ± .38	1.6 ± .52	17	-1.0	.16
10	2.3 ± .70	2.1 ± .70	9.3	.52	.31
15	2.4 ± .67	2.1 ± .82	15	.78	.22
16	2.2 ± .84	1.9 ± .64	18	-1.0	.16
22	2.5 ± .61	2.2 ± .81	5.1	-.75	.24
23	2.4 ± .51	2.0 ± .38	13	1.6	.07
28	2.1 ± .71	2.1 ± .70	12	.07	.47
29	2.1 ± .83	1.9 ± .67	15	-1.1	.14

As has already been mentioned, students were selected for the interviews based on their responses to the multiple choice version of the test. Their answers to the multiple choice version of the test were available to the interviewer during the interview. Thus, data was collected as to whether or not their answers changed from the multiple choice version and whether or not they changed toward the correct answer. There were 28 students interviewed. Each student was interviewed on the same 10 questions. Thus, there are 280 possibilities for an answer to change from the multiple-choice examination. On average, 33% of the students (93 out of 280) changed their answer with 42% of them (39 of the 93) changing toward the correct answer. In general, more females changed their answers than did the males. On 7 of the 10 questions, higher percentages of the females moved toward the correct answer than did the males.

Explanations can be offered for those questions having the highest number of changes. Question 22 was selected because it was believed that students may have been choosing the correct circuit but not the correct multiple choice response. The interviews confirmed this. Question 23 confused a few students in terms of how they interpreted the words "Immediately after." The interview allowed clarification. Question 28 revealed that some students had not read the question carefully enough and believed that the switch would be closed instead of remaining open. Changes with question 8 may be a result of the students taking more time than in the testing situation.

Student definitions to terms used on the test were discussed previously in this chapter. An examination of their erroneous definitions and the dominant misconception for each question revealed a relationship for 5 of the 10 questions. Questions 3 and 8 show a confusion between current and energy in the misconceptions of battery as a constant current source and current consumed. Questions 15 and 28 show confusion between current and voltage in the misconceptions of battery as a constant current source and term confusion I/V . Question 23 has the main misconception of confusion between resistance and current. Although most of the

students have an acceptable definition of resistance, it appears that there may be the hidden assumption that the resistive element does the consuming when students define resistance as a reduction in current. The data on student definitions of terms and student misconceptions indicates that the main source of difficulty is with term confusion, generally associated with current. The properties of energy are translated to current while the properties of current are translated onto voltage and resistance. Typically, current is the first concept that is introduced and the other terms are defined through it via Ohm's law. In general, there is an overemphasis placed on Ohm's law in many of the texts. Students may come away from the course believing that Ohm's law is true in all situations, which is not the case (Arons, 1990, p. 180).

4.3 DIRECT version 1.1

DIRECT version 1.1 differs from version 1.0 in the number of available alternatives and the order of some figures (for example, see Figures 4.5 and 4.21). The wording of some questions and alternatives were clarified. No new items were added, although the focus of some items did change with the addition of more alternatives. Similar to the discussion of the analysis of version 1.0, analysis of version 1.1 will begin with an examination of the questions with respect to discrimination and difficulty. Student performance with regard to the objectives will be discussed next, followed by an examination of individual and groups of questions. Results from multiple students' *t*-tests will be discussed.

4.3.1 DIRECT version 1.1 Discrimination and Difficulty Indices

Examining the discrimination indices (see Tables 4.16-18; Graphical representation of the first five columns of Table 4.16 can be found in Appendix G) for the 29 questions revealed that question 14 was the most discriminating overall and for the university group. However, question 27 was the most discriminating for the high school students. Question 14 is shown in Figure 4.19. Students who answered this question correctly had to understand how to calculate the equivalent resistance for resistors in a series/parallel combination and to compare that

equivalent resistance to that of two resistor in series. For question 27 shown in Figure 4.20, students need to have the declarative knowledge of the location of the contact points for the light bulb. For all groups, question 11 (see Figure 4.21) proved the least discriminating. Students typically chose answer E that the charges push each other through the wires like marbles in a tube. This is incorrect. The motion of the charges is very chaotic. Some charges will collide and exchange energy but they do not line up and push each other through the wires.

14) How does the resistance between the endpoints change when the switch is closed?

(A) Increases by R
 (B) Increases by $R/2$
 (C) Stays the same
 (D) Decreases by $R/2$
 (E) Decreases by R

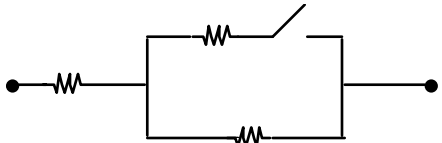
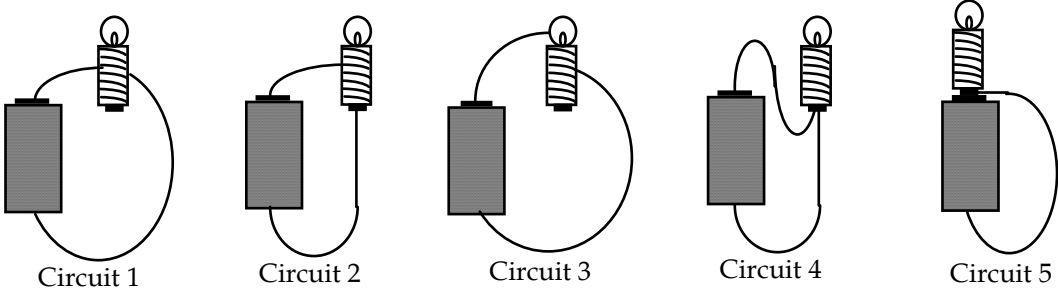

Figure 4.19: Question 14 from DIRECT version 1.1

27) Will all the bulbs be the same brightness?



Circuit 1 Circuit 2 Circuit 3 Circuit 4 Circuit 5

(A) Yes, because they all have the same type of circuit wiring.
 (B) No, because only Circuit 2 will light.
 (C) No, because only Circuits 4 and 5 will light.
 (D) No, because only Circuits 1 and 4 will light.
 (E) No, Circuit 3 will not light but Circuits 1, 2, 4, and 5 will.

Figure 4.20: Question 27 from DIRECT version 1.1

Table 4.16: Overall results for DIRECT version 1.1

Question Number and Correct Answer	A	B	C	D	E	Omitted	Point Biserial Correlation	Discrimination	Difficulty	
1	E	0.13	0.04	0.03	0.42	0.38	0.01	0.28	0.23	0.38
2	E	0.01	0.13	0.33	0.47	0.07	0.00	0.25	0.07	0.07
3	C	0.07	0.27	0.46	0.03	0.17	0.00	0.38	0.32	0.46
4	D	0.06	0.35	0.02	0.37	0.19	0.00	0.35	0.32	0.37
5	A	0.39	0.27	0.17	0.10	0.06	0.01	0.44	0.38	0.39
6	E	0.21	0.05	0.06	0.14	0.54	0.00	0.33	0.29	0.54
7	B	0.03	0.51	0.02	0.21	0.22	0.00	0.41	0.35	0.51
8	C	0.14	0.04	0.74	0.07	0.00	0.00	0.35	0.25	0.74
9	D	0.11	0.05	0.08	0.72	0.04	0.00	0.44	0.35	0.72
10	E	0.03	0.00	0.55	0.08	0.34	0.00	0.25	0.17	0.34
11	A	0.04	0.10	0.17	0.22	0.47	0.00	0.00	0.01	0.04
12	D	0.41	0.19	0.10	0.20	0.10	0.00	0.41	0.21	0.20
13	C	0.02	0.06	0.82	0.02	0.08	0.00	0.33	0.20	0.82
14	D	0.18	0.22	0.13	0.41	0.07	0.00	0.52	0.43	0.41
15	C	0.02	0.12	0.49	0.32	0.04	0.00	0.31	0.22	0.49
16	C	0.06	0.18	0.57	0.15	0.04	0.00	0.17	0.14	0.57
17	D	0.08	0.09	0.23	0.43	0.17	0.01	0.41	0.32	0.43
18	C	0.00	0.02	0.46	0.50	0.01	0.00	0.29	0.18	0.46
19	C	0.03	0.13	0.62	0.10	0.12	0.00	0.38	0.29	0.62
20	E	0.17	0.10	0.06	0.51	0.14	0.01	0.10	0.03	0.14
21	D	0.03	0.03	0.25	0.52	0.16	0.01	0.27	0.19	0.52
22	B	0.03	0.44	0.09	0.02	0.42	0.00	0.33	0.27	0.44
23	D	0.12	0.07	0.09	0.40	0.32	0.00	0.36	0.26	0.40
24	D	0.47	0.08	0.13	0.24	0.06	0.01	0.43	0.29	0.24
25	A	0.05	0.60	0.27	0.06	0.01	0.01	0.20	0.05	0.05
26	D	0.44	0.07	0.06	0.40	0.04	0.00	0.42	0.32	0.40
27	B	0.05	0.73	0.07	0.02	0.13	0.01	0.39	0.30	0.73
28	D	0.45	0.03	0.16	0.24	0.10	0.02	0.13	0.06	0.24
29	B	0.39	0.19	0.11	0.17	0.10	0.03	0.22	0.16	0.19
Average								0.32	0.23	0.41

Table 4.17: University results for DIRECT version 1.1

Question Number	A	B	C	D	E	Omitted	Point Biserial Correlation	Discrimination	Difficulty
1	0.12	0.04	0.03	0.41	0.40	0.01	0.27	0.22	0.40
2	0.00	0.14	0.36	0.42	0.07	0.00	0.27	0.08	0.07
3	0.06	0.29	0.48	0.04	0.14	0.00	0.43	0.36	0.48
4	0.06	0.30	0.02	0.44	0.17	0.00	0.33	0.32	0.44
5	0.52	0.24	0.11	0.06	0.07	0.00	0.40	0.34	0.52
6	0.22	0.05	0.05	0.10	0.58	0.00	0.35	0.29	0.58
7	0.02	0.55	0.02	0.21	0.20	0.00	0.40	0.32	0.55
8	0.14	0.03	0.80	0.04	0.00	0.00	0.29	0.20	0.80
9	0.11	0.04	0.08	0.74	0.03	0.00	0.41	0.31	0.74
10	0.03	0.01	0.50	0.09	0.37	0.00	0.24	0.15	0.37
11	0.04	0.08	0.16	0.17	0.55	0.00	0.03	0.01	0.04
12	0.35	0.22	0.10	0.23	0.10	0.00	0.41	0.23	0.23
13	0.01	0.04	0.88	0.01	0.05	0.00	0.23	0.10	0.88
14	0.10	0.23	0.10	0.52	0.05	0.00	0.50	0.44	0.52
15	0.01	0.09	0.53	0.33	0.04	0.00	0.28	0.17	0.53
16	0.07	0.17	0.56	0.15	0.04	0.01	0.18	0.16	0.56
17	0.06	0.06	0.20	0.51	0.16	0.01	0.42	0.35	0.51
18	0.00	0.02	0.46	0.51	0.00	0.00	0.41	0.31	0.46
19	0.02	0.12	0.66	0.09	0.11	0.00	0.37	0.29	0.66
20	0.20	0.10	0.07	0.49	0.14	0.00	0.12	0.07	0.14
21	0.03	0.02	0.28	0.46	0.20	0.00	0.35	0.31	0.46
22	0.02	0.47	0.06	0.01	0.44	0.00	0.34	0.28	0.47
23	0.13	0.07	0.07	0.43	0.30	0.00	0.33	0.20	0.43
24	0.44	0.08	0.13	0.29	0.06	0.01	0.47	0.35	0.29
25	0.07	0.57	0.28	0.07	0.01	0.01	0.21	0.05	0.07
26	0.46	0.05	0.05	0.41	0.03	0.01	0.47	0.39	0.41
27	0.03	0.76	0.07	0.02	0.12	0.00	0.33	0.23	0.76
28	0.44	0.02	0.17	0.27	0.07	0.03	0.05	0.01	0.27
29	0.41	0.23	0.12	0.11	0.09	0.04	0.34	0.22	0.23
Average							0.32	0.23	0.44

Table 4.18: High school results for DIRECT version 1.1

Question Number	A	B	C	D	E	Omitted	Point Biserial Correlation	Discrimination	Difficulty
1	0.14	0.05	0.03	0.43	0.34	0.00	0.28	0.24	0.34
2	0.01	0.12	0.26	0.55	0.07	0.00	0.24	0.10	0.07
3	0.08	0.24	0.43	0.01	0.23	0.01	0.29	0.22	0.43
4	0.05	0.44	0.03	0.26	0.21	0.01	0.28	0.25	0.26
5	0.18	0.33	0.28	0.16	0.04	0.02	0.34	0.24	0.18
6	0.19	0.06	0.06	0.21	0.47	0.01	0.24	0.17	0.47
7	0.05	0.45	0.02	0.22	0.25	0.01	0.41	0.33	0.45
8	0.14	0.07	0.65	0.13	0.00	0.01	0.37	0.28	0.65
9	0.12	0.07	0.07	0.67	0.07	0.00	0.49	0.40	0.67
10	0.03	0.00	0.63	0.05	0.29	0.00	0.22	0.19	0.29
11	0.04	0.15	0.18	0.29	0.34	0.00	-0.04	0.00	0.04
12	0.51	0.14	0.10	0.15	0.10	0.00	0.36	0.19	0.15
13	0.03	0.08	0.71	0.02	0.15	0.00	0.37	0.26	0.71
14	0.31	0.20	0.18	0.21	0.09	0.00	0.41	0.23	0.21
15	0.04	0.17	0.42	0.31	0.05	0.01	0.32	0.26	0.42
16	0.04	0.21	0.57	0.15	0.04	0.00	0.18	0.13	0.57
17	0.10	0.13	0.27	0.29	0.20	0.01	0.26	0.12	0.29
18	0.00	0.02	0.46	0.50	0.01	0.00	0.08	0.04	0.46
19	0.05	0.13	0.56	0.12	0.14	0.00	0.38	0.33	0.56
20	0.12	0.10	0.06	0.55	0.15	0.02	0.06	0.09	0.15
21	0.03	0.05	0.21	0.61	0.09	0.01	0.28	0.18	0.61
22	0.04	0.38	0.13	0.04	0.39	0.01	0.29	0.25	0.38
23	0.09	0.09	0.12	0.34	0.35	0.01	0.38	0.25	0.34
24	0.54	0.09	0.15	0.16	0.06	0.00	0.28	0.10	0.16
25	0.03	0.65	0.25	0.05	0.02	0.01	0.14	0.05	0.03
26	0.41	0.10	0.08	0.37	0.05	0.00	0.35	0.28	0.37
27	0.08	0.69	0.06	0.02	0.15	0.01	0.50	0.40	0.69
28	0.45	0.05	0.15	0.20	0.14	0.01	0.23	0.10	0.20
29	0.37	0.12	0.10	0.28	0.11	0.01	0.15	0.07	0.12
Average							0.28	0.20	0.35

- 11) Why do the lights in your home come on almost instantaneously when you turn on the switch?
- (A) When the circuit is completed, there is a rapid rearrangement of surface charges in the circuit.
 - (B) Charges store energy. When the circuit is completed, the energy is released.
 - (C) Charges in the wire travel very fast.
 - (D) The circuits in a home are wired in parallel. Thus, a current is already flowing.
 - (E) Charges in the wire are like marbles in a tube. When the circuit is completed, the charges push each other through the wire.

Figure 4.21: Question 11 from DIRECT version 1.1

As with version 1.0, question 13 (see Figure 4.22) again proved itself to be the least difficult. However, there was a decrease in the percentage of students who got this item correct. Overall and for the university groups, question 11 shown in Figure 4.21 was the most difficult. The reason has already been explained in the discussion of the discrimination index. For the high school students, question 25 (see Figure 4.23) proved the most difficult. Sixty-five percent of the students chose option B that bulb A is twice as bright as bulb B. They either arrived at this answer by considering the current or the voltage only. In this case, both are reduced by half. Thus, students were not equating brightness with power which is a combination of current and voltage.

13) Which schematic diagram best represents the realistic circuit shown below?

- (A) Circuit 1
- (B) Circuit 2
- (C) Circuit 3
- (D) Circuit 4
- (E) None of the above

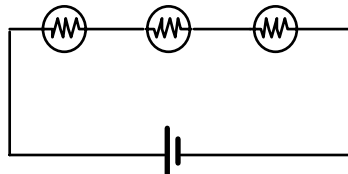
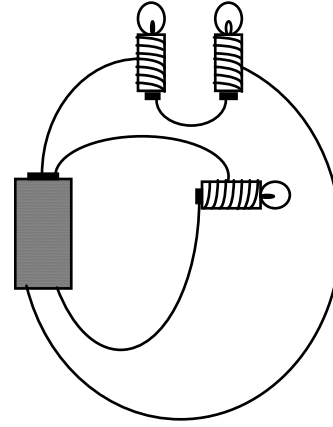

Circuit 1

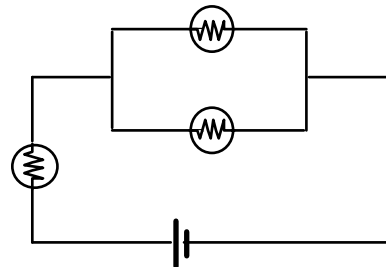

Circuit 2

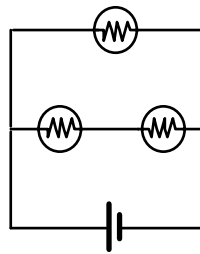

Circuit 3

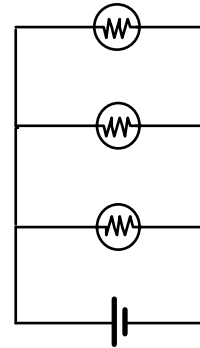

Circuit 4

Figure 4.22: Question 13 from DIRECT version 1.1

25) Compare the brightness of bulb A with bulb B. Bulb A is ____ bright as bulb B.

(A) Four times as
 (B) Twice as
 (C) Equally
 (D) Half as
 (E) One fourth ($1/4$) as

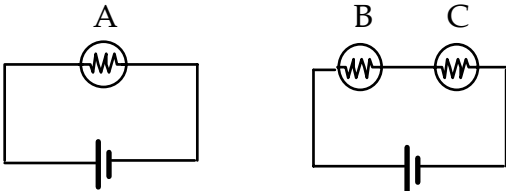

Figure 4.23: Question 25 from DIRECT version 1.1

4.3.2 DIRECT version 1.1 Objectives

Table 4.19 shows the percent correct and the associated question numbers for each of the objectives as well as for the four main categories. Overall, students found objective 5 on resistance the easiest and objective 9 questions dealing with the microscopic aspects of circuits the most difficult. As with version 1.0, students did better on questions dealing with the physical aspects of the circuit and equally well on those questions dealing with current, energy, and voltage. An examination of the distracters of the test reveals that on average 15% of the students cannot identify a short in a circuit and/or determine what affect the short has on the circuit, 9.1% do not know where the contacts are on a light bulb, 4.8% have trouble identifying a complete circuit, and 23% exhibit current/voltage confusion. It should be noted that the values just reported are not above chance.

Table 4.19: Student performance for each objective for DIRECT version 1.1

	Question Numbers	Objective Number	Percent Correct
Physical aspects of DC electric circuits	4, 5, 9, 10, 13, 14, 18, 19, 22, 23, 27	1 - 5	0.52
Energy	2, 3, 12, 21	6 - 7	0.34
Current	1, 8, 11, 17, 20	8 - 9	0.35
Potential difference (Voltage)	6, 7, 15, 16, 24, 25, 28, 29	10 - 11	0.35
Circuit layout	4, 9, 10, 13, 18, 19, 22, 27	1 - 3 and 5	0.56
Short circuit	10, 19, 27	1	0.48
Functional two-endedness and Complete circuit	9, 18	2 and 3	0.59
Short circuit, Functional two-endedness and Complete circuit	27	1, 2, and 3	0.73
Resistance	5, 14, 23	4	0.40
Diagrams	4, 13, 22	5	0.54
Power	2, 12 (7, 16, 25)	6	0.28
Energy	3, 21	7	0.49
Current	1, 8, 17	8	0.52
Micro-macro	11, 20	9	0.09
Ohm's law	7, 16, 25	10	0.38
Potential difference	6, 15, 24, 28, 29	11	0.34
Current and Voltage	26	8 and 11	0.40

4.3.3 DIRECT version 1.1 Groups of questions

The results of an examination of the patterns of answers and option choices for DIRECT version 1.1 reveal a similar pattern to that discussed in section 4.2.3. Specific differences in the results between versions 1.0 and 1.1 will be discussed in section 4.5.

Questions 3, 7, 12, and 16 contain batteries that are in series and/or parallel. Students again found these problems somewhat difficult. The average difficulty on this group of problems is 44% which means that over fifty percent of the students were getting them wrong, especially question 12. Errors were most often associated with what happened with the parallel battery. To further investigate, how students viewed multiple batteries, question 7 was

altered from version 1.0. Figures 4.24 and 4.25 show the two questions. Table 4.20 shows the correlation between questions 3 and 7. The bolded values are statistically significant. Students who selected circuit 3 in question 3 tended to select that two batteries in series provide more voltage in question 7. Students who chose circuit 2 in question 3 tended to chose option D in question 7, that two batteries in parallel provided more voltage. Those student who said that circuits 2 and 3 were equal in question 3 also said that they had the same voltage in question 7.

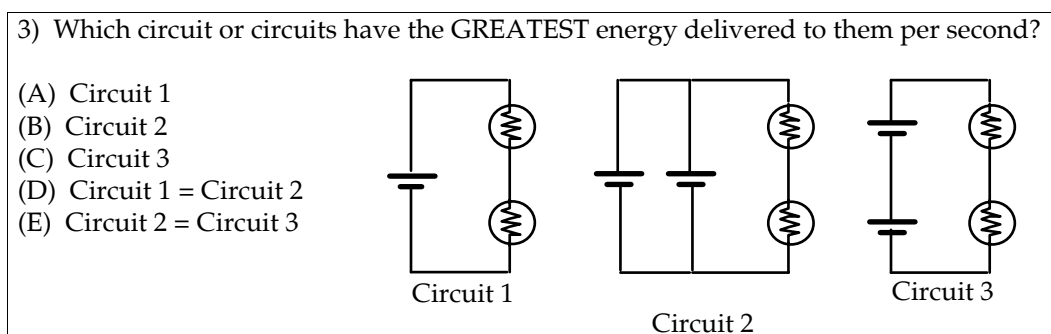

Figure 4.24: Question 3 from DIRECT version 1.1

7) Compare the brightness of the bulb in circuit 1 with that in circuit 2. Which bulb is BRIGHTER?

- (A) Bulb in circuit 1 because two batteries in series provide less voltage
- (B) Bulb in circuit 1 because two batteries in series provide more voltage
- (C) Bulb in circuit 2 because two batteries in parallel provide less voltage
- (D) Bulb in circuit 2 because two batteries in parallel provide more voltage
- (E) Neither, they are the same

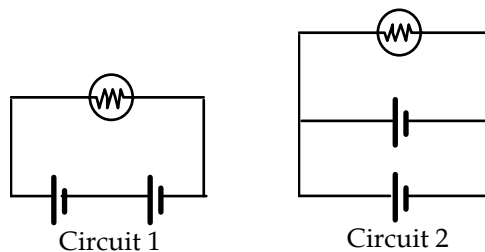

Figure 4.25: Question 7 from DIRECT version 1.1

Table 4.20: Correlation values for questions 3 and 7

	3a	3b	3c	3d	3e
7a	-.01	.01	.01	-.03	-.01
7b	-.06	-.27	.45	.01	-.25
7c	.00	.06	-.03	.09	-.07
7d	.06	.37	-.30	.02	-.08
7e	.00	-.06	-.24	-.05	.41

4.3.4 DIRECT version 1.1 Group comparisons

t -tests were performed on various groups of students who took DIRECT version 1.1. The results of these tests will now be presented. The raw scores were used in these calculations so that a score of 29 is equivalent to 100%. There were significant differences in the means for the university ($M = 13$) and high school groups ($M = 10$), $t(589) = 8.5$, $p < 1.1 \times 10^{-16}$, with university students outperforming high school students. Significant differences were found between males ($M = 13$) and females ($M = 10$), $t(429) = 6.4$, $p < 1.8 \times 10^{-10}$, with males outperforming females. There were no significant differences between calculus-based ($M = 13$) and algebra-based university students ($M = 12$), $t(267) = .77$, $p < .21$. However, there was a small group of students who used the *Physics by Inquiry* materials which uses an inquiry approach to instruction with a great number of hands-on activities. An analysis of variance (ANOVA) was performed. The students' t -test allows one to compare the means of two groups. ANOVA allows one to compare the means of more than two groups. Results showed that there were significant differences found between the students using the *Physics by Inquiry* materials ($M = 15$) and, the calculus-based students ($M = 13$), and the algebra-based students ($M = 12$), $F(2, 438) = 4.13$, $p < .017$. Those students using *Physics by Inquiry* outperformed both groups.

This administration of DIRECT also contained 228 foreign students from Canada and Germany. The German students were equivalent to high school students. There were two groups of Canadian students, one equivalent to university students and the other equivalent to high school students. A t -test comparing the mean scores for students in the United States ($M = 12$) and mean scores for the foreign students ($M = 12$), $t(431) = .52$, $p < .30$, revealed no significant differences. However, analysis of variance revealed that there were significant differences between the three countries with Canadian students ($M = 13$) apparently outperforming the German ($M = 9.6$) and US ($M = 12$) students, $F(2, 689) = 20.6$, $p < 2.0 \times 10^{-9}$. Since there were two groups of Canadian students, additional t -tests and ANOVAs were

performed. Results indicate a significant difference between the Canadian ($M = 13$) and US university students ($M = 12$), $t(226) = -2.8, p < .002$, with Canadian students outperforming the US students. An examination of the performance between the male and female university students in both countries shows that there are significant differences in the scores of males and females (see Table 4.21). Males outperformed the females in each case. An ANOVA comparison of the high school student groups shows that there are significant differences between the three countries: Canada ($M = 12$), Germany ($M = 9.6$), and United States ($M = 10$), $F(2, 248) = 7.7, p < .0006$. Again, comparing the performance of males and females in each country shows significant differences between males and females with males outperforming females (see Table 4.22).

Table 4.21: t -test results for university students in Canada and the United States

Group	Mean and standard deviation for Males	Mean and standard deviation for Females	Degrees of freedom	t	p -value
Canada	14 ± 4.1	12 ± 3.8	24	1.9	.03
United States	13 ± 4.3	11 ± 3.5	204	3.4	.0005

Table 4.22: t -test results for high school students in Canada, Germany and the United States

Group	Mean and standard deviation for Males	Mean and standard deviation for Females	Degrees of freedom	t	p -value
Canada	13 ± 4.6	11 ± 3.7	46	1.9	.03
United States	11 ± 3.1	7.4 ± 1.9	54	6.5	1.4×10^{-8}
Germany	11 ± 3.2	8.8 ± 3.4	79	2.5	.007

4.3.5 DIRECT version 1.1 Pre/post-instruction data

Additional data was collected from North Carolina State University and Seton Catholic High School in Chandler, AZ. Students were given the exam prior to and following instruction on electric circuits. The data from NCSU is complete. However, the data from Seton High School is missing questions 26 and 27 due to an oversight during the reproduction of the exam. Figures 4.26 and 4.27 show the histogram for each test site. Tables 4.23 and 4.24 provide the statistical data associated with each administration.

Paired two-sample t -tests using the raw scores show that there are significant differences in the means between pre- and post-instruction for both test sites (See Table 4.25). In both cases, the post-instruction scores were much better than the pre-instruction scores. This provides additional evidence of content validity. The Pearson correlation for the NCSU data was 0.61 and for the Seton data 0.16. It is unclear exactly why there is such a discrepancy between the two Pearson correlations. However, it could be a combination of the Seton's small range which resulted in lower standard deviations as compared to NCSU. A comparison of the NCSU post-instruction data ($M = 13$) with the data from the 1996 administration ($M = 13$), $t(21) = .64$, $p < .26$, shows no significant difference between the two calculus-based groups. There was a significant difference between the Seton high school post-instruction data ($M = 9.9$) and the high school data from the 1996 administration ($M = 9.2$), $t(229) = 2.0$, $p < .02$. Questions 26 and 27 were removed from the 1996 high school data in order to do the comparison. The difference may be associated with the use of some CASTLE materials by the Seton high school students, which provides insights into the microscopic aspects of circuits as well as provides hands-on experiences.

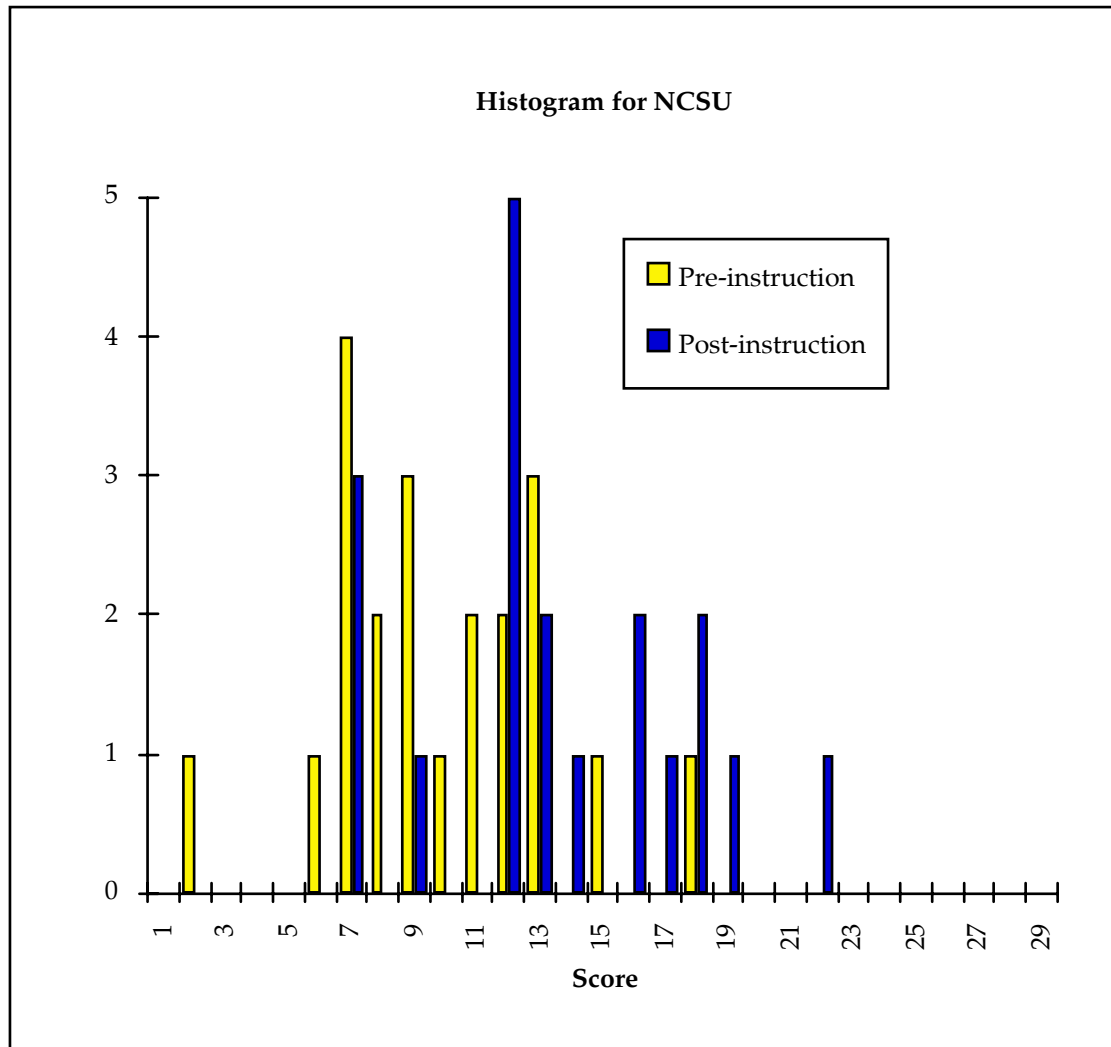

Figure 4.26: Frequency distribution for pre- and post-instructional data using DIRECT version 1.1 at North Carolina State University (NCSU)

Table 4.23: Pre/post-instruction data from NCSU (all 29 questions)

	Pre-instruction	Post-instruction
Mean	34%	46%
Median	31%	45%
Mode	24%	41%
Standard Deviation	12%	15%
Range	55%	52%
Minimum (0)	6.9%	24%
Maximum (100)	62%	76%
N	21	19

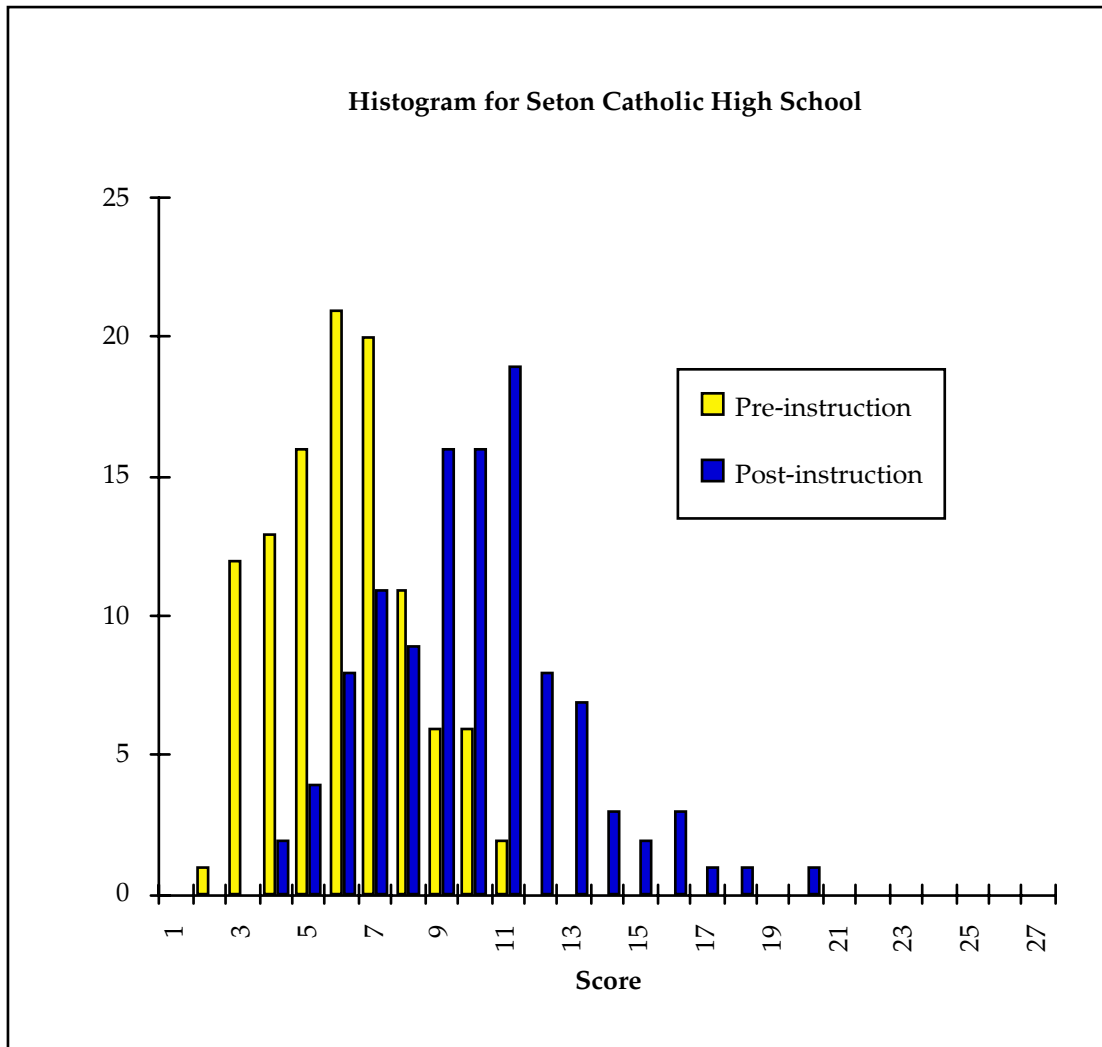

Figure 4.27: Frequency distribution for pre- and post-instructional data using DIRECT version 1.1 at Seton Catholic High School

Table 4.24: Pre/post-instruction data from Seton Catholic High School (missing questions 26 and 27)

	Pre-instruction	Post-instruction
Mean	23%	38%
Median	22%	37%
Mode	22%	41%
Standard Deviation	7.6%	11%
Range	33%	59%
Minimum (0)	7.4%	15%
Maximum (100)	41%	74%
N	108	111

Table 4.25: Paired t -test results for NCSU and Seton Catholic High School

Group	Mean and standard deviation for Pre-instruction	Mean and standard deviation for Post-instruction	Degrees of freedom	<i>t</i>	<i>p</i> -value
NCSU	10 ± 3.3	14 ± 4.2	16	-4.6	.0001
Seton	6.1 ± 2.1	10 ± 3.0	107	-12	7.6 × 10 ⁻²²

4.4 Results from the Factor Analyses of versions 1.0 and 1.1

A factor analysis is another way to gain evidence of validity. This procedure analyzes the interrelationships of data. It allows the data to be simplified (Anastasi, 1988, pp. 154-5). "In a factor analysis, the correlations between all items are analyzed in order to select groups of items that all appear to measure the same idea" (Huffman & Heller, 1995, p. 138) or factor⁴. The factor analyses of versions 1.0 and 1.1 were performed using SAS JMP 3.1.6 Statistics Made Visual computer software which utilizes the Little Jiffy method. The Little Jiffy method recommends that all factors having an eigenvalue of 1 or better should be kept (Nichols, 1985, p. 13-8). Using this method revealed eight factors associated with version 1.0 and 11 factors associated with version 1.1. Tables 4.26 and 4.27 show the factor loading for each question, variance accounted for by each factor, the questions associated with each factor for each version of the test, and the meaning of each factor.

⁴For a description of how to conduct a factor analysis, refer to Huffman, D. & Heller, P. (1995). What Does the Force Concept Inventory Actually Measure?. *The Physics Teacher*, **33**, 138-143.

Table 4.26: Results from the factor analysis of version 1.0

Factor Number	Variance Accounted for by this factor	Questions and Factor Loading	Meaning of Factor	
1	12.42	14 22 27	-0.46 -0.73 -0.64	Examines students' ability to reason appropriately about the physical aspects of the circuit
2	6.29	2 21 25 26	-0.58 -0.70 -0.77 -0.64	Series circuits with a change in the resistance. The change increases the resistance of the circuit. Students cannot use battery as a constant current source or current consumed in answer these questions
3	5.16	3 7 12	-0.74 -0.66 -0.56	Examines students' ability to reason appropriately about batteries in series and parallel
4	4.23	10 11 18 24	.63 .52 .52 .37	Examines students' understanding of current , its properties and under what conditions a current will occur
5	4.16	4 5 9 13 19 23	-0.45 -0.39 -0.59 -0.36 -0.52 -0.46	Examines students' ability to reason appropriately about the physical aspects of the circuit
6	3.89	1 16 19	.31 .75 .31	Unclear. Questions 1 and 19 may be related. However, 19 also appears in Factor 5. May be dealing with how students view charge flow and the path that charges follow through the circuit
7	3.82	6 8 15 17 29	.51 .46 .59 .38 .47	Examines students' ability to differentiate between current and voltage
8	3.70	20 28	-0.78 .31	Unclear. These two are probably separate issues. Question 20 deals with students knowledge of how a current is formed while question 28 deals with students knowledge of an open circuit

Table 4.27: Results from the factor analysis of version 1.1

Factor Number	Variance Accounted for by this factor	Questions and Factor Loading	Meaning of Factor
1	11.77	4 .48 5 .65 8 .46 13 .33 14 .67 17 .59 24 .38	Examines students' ability to reason appropriately about all aspects of the circuit
2	5.51	10 -.45 21 .63 26 .57 29 .55	Examines students' ability to reason appropriately about changes in resistance . Students cannot use battery as a constant current source or current consumed .
3	5.12	3 .77 7 .77 12 .55	Examines students' ability to reason appropriately about batteries in series and parallel
4	4.89	22 .53 27 .66	Examines students' ability to reason appropriately about the physical aspects of the circuit
5	4.38	2 .74 25 .72	Examines students' ability to reason appropriately about changes in resistance through the concept of power and to use ratios correctly
6	4.14	6 .37 28 .77	Examines students' ability to differentiate between current and voltage
7	3.86	1 .46 16 .63 19 .46 23 .43	Examines how students deal with charge flow and the path that charges follow through the circuit as well as the concept of an open circuit
8	3.74	6 -.38 11 .81	Unclear. Question 6 deals with students' understanding of potential difference in a series circuit and question 11 deals with students' understanding of how a current occurs in an appliance.
9	3.73	20 .88	Examines students' knowledge of how a current is formed
10	3.59	9 .40 15 .75	Unclear. Question 9 examines students' understanding of a complete circuit while question 15 examines their understanding of potential difference in a parallel circuit
11	3.53	18 .81	Examines students' knowledge of complete circuits and the affects of shorting wires on the circuit

Although one would prefer to have the factor analysis align directly with the objectives of the exam, the patterns that have emerged are consistent with what one would expect after a careful examination of the questions (refer to sections 4.1.3 and 4.3.3).

4.5 Comparison of DIRECT versions 1.0 and 1.1 and problems with each version

This section will compare the results of the two versions of the test as well as identify problems with each. One global problem with version 1.0 is the inconsistent number of alternatives presented to the students. The number of choices ranged from 3 to 5. This varied the chance of guessing from 33% to 20%, respectively. A difficulty that arose during the development of version 1.1 was trying to quantify those questions which used light bulbs in the circuits so more alternatives could be included. The light bulbs are non-Ohmic, which means they do not obey Ohm's law, so one cannot use the equations for power, $P = IV$, etc. However, this is what was expected on those questions. It is unclear as to whether or not the students appreciated this subtle distinction. To remedy this problem on future versions of the test, one would need to either change the light bulbs to resistors or return to version 1.0 style questions, it increases, decreases or stays the same, with the addition of the reasoning behind those responses.

Some wording changes need to be made to improve the tests, such as changing "power delivered" to "power dissipated by resistor x" and instead of "which bulb is brighter" to "which, if either, bulb is brighter." The length of the alternatives needs to be made more consistent on questions 1, 11, and 20 so that the length of the alternative does not influence student's choice. Students may be associating the length of the alternative with correctness (Mehrens & Lehmann, 1991, p. 137). Questions that supposedly dealt with the concept of energy are interpreted by the students and panels of experts as power questions. If the energy concept is to continue to be tested, new questions will need to be developed that address it

more directly. Some circuits like the ones in question 3 could be simplified to eliminate unnecessary complexity. Also, the contact points on the circuits with “realistic” circuit elements need to be fully in contact in the drawings where appropriate.

Before preceding with a comparison of the results and additional problems with specific questions, a comparison of the mean scores for the two versions will be explored. Recall that the mean score for version 1.0 was $48 \pm .45\%$ and for version 1.1 the mean score was $41 \pm .55\%$. A t -test was performed using the raw scores which indicated that there was a significant difference between the means of version 1.0 ($M = 14$) and version 1.1 ($M = 12$), $t(1508) = 11$, $p < 4.0 \times 10^{-26}$. Students performed better on version 1.0 than on 1.1. The explanation may lie with the more quantitative nature of version 1.1. Students had to determine by how much one bulb was brighter than another. As already mentioned, this quantification is in error since bulbs do not obey Ohm’s law. Students’ choices indicate that they are focusing on changes in the current in answering some of these style questions.

Some questions either did not change or had slight changes in the wording from version 1.0 to version 1.1. The results from these questions did not change either. These questions include 3, 6, 10 (a slight change in the wording of the question), 12, 19 (slight change in wording of options), 21 (a slight change in the wording of the question), 24, 26, and 29. The remaining questions had more subtle changes made with corresponding changes in the results. For a graphical representation of the data, see Appendix G. For numerical data, see Tables 4.1-3 and 4.16-18.

The interview results indicated that students could arrive at the correct answer choice via misconceptions on questions 10 and 15. The simplest solution to this problem would be to add the reasoning behind the answer selection to the alternatives. For example, question 10 (see Figure 4.7) answer choice E may be changed to read “A = C because the current to A and C is the same.” The alternative reasoning would be determined from the interview results, if possible. Otherwise, additional interviews may need to be conducted. Interviews would be

preferable over written justifications since some students may be better able and more willing to express themselves verbally (Best, 1981, pp. 164-5).

Questions 1, 11, and 20 aimed at examining students' understanding of the microscopic aspects of current and how current is formed. Changes were made from version 1.0 to version 1.1 but further improvements are needed. The wording of each question was changed and additional alternatives added. The length of the alternatives may be influencing the students' selections. The alternatives on question 1 are not consistent. Those alternatives which use the wording "charge is conserved" may be drawing students to those answer choices simply as a matter of recall. There are small changes in the distribution of answers from version 1.0 to version 1.1 on question 1. With question 11, the addition of option E resulted in a decrease in the number of students who selected options A and D. The alternatives for question 20 were reworded to clarify if students believed that the electric field in the bulb's filament was formed by the current or by some other means. In general, the results are consistent from version 1.0 to version 1.1 on this question.

Questions 2, 5, 14, 15, 16, and 25 had similar changes made to them from version 1.0 to version 1.1. The alternatives were changed from increase, decrease, or stays the same, to be more quantitative, bulb A is x times brighter than bulb B. Questions 14 and 15 were changed to ask how much of an increase occurred. The difficulty (here the term is being using to indicate that the percentage incorrect increased) increased on questions 2, 5 and 25 and remained approximately the same on questions 14, 15, and 16. The increase in difficulty on questions 2, 5, and 25 may be explained in their use of current as the primary concept in analyzing changes in circuits.

Questions 4, 9, 13, 18, 22, and 27 deal with students' understanding of the physical aspects of the circuits. These questions were modified in one of three ways: the circuit diagrams were presented in a different order, changes were made to the diagrams themselves, or additional alternatives were added. The alterations made to the questions did not result in a

significant change in the responses for questions 4, 9, 13, or 27. Interview data indicated that students did not understand the representation of a light bulb in a socket in question 18. Thus, the diagrams were re-drawn using only the battery, bulb and wires. As a result, the difficulty decreased from version 1.0 to version 1.1. It was suspected that students may have chosen the correct circuit on question 22 but bubbled in the incorrect alternative on the Opscan sheet. The labels of the circuits were changed from letters to circuit 1, etc. There was a slight decrease in difficulty with this modification.

The results from version 1.0 indicated that students did not understand how batteries connected in series or in parallel affected the circuit. Question 7 was changed to examine students' belief about multiple batteries. The results have previously been presented in 4.3.3.

Questions 8 and 17 deal with students' understanding of current. Examining question 8 shows that students choosing options A or B believe that current is consumed. Those choosing option C on version 1.0 may have the correct view that current is conserved but they may also be using the clashing currents model. To test this, option D was added on version 1.1. The results indicate that approximately seven percent of the students may be using this model. However, students may also be confusing the reasoning presented in option D with the way in which conventional current and electron current are defined. Alternative A was changed on question 17 from "5, 1, 3, 2, 4, 6" to "5, 3, 1, 2, 4, 6." This change examines students' belief that current is consumed. The change resulted in only a slight increase from 0.02 on version 1.0 to 0.08 on version 1.1.

Question 23 poses a problem since, depending on the interpretation of the question, there can be two correct alternatives. The intent of the question is for students to answer that the resistance does not change when the switch is opened. However, some students may correctly answer that the resistance decreases. The problem is in the interpretation of the words "Immediately after." A light bulb is a resistor but it is non-Ohmic. The resistance of the light bulb increases non-linearly as the bulb heats up and decreases as the bulb cools. The

researcher associates no time passage with those words so that there has not been a temperature change. Some students and instructor's who have administered the test assume that there is a time lapse and thus a temperature change. This question could be clarified by adding that there is no temperature change but the researcher feels that this would unduly influence the students' thinking toward the correct answer by aiding them in a recall of information from the classroom or text. Another option is to simply change the diagram and question so that the circuit remains open and ask what the resistance is under these conditions. This latter option is the change that will most likely be made to future versions of the test.

The wording of question 23 was not changed from version 1.0 to version 1.1. Only an additional alternative was added which was that the resistance goes to infinity. This addition, however, only resulted in a slight redistribution of the alternatives. The results are basically the same.

The alternative, none of the above, was added to question 28. This change did not significantly affect the distribution of answers. However, a better alternative may be either 4V or 8V. Students may assume that the switch has the same resistance as each of the two bulbs. It's not clear which new alternative would be better. Additional testing on this particular question with one version containing the 4V option and another containing the 8V option would need to be undertaken. Students would be required to explain in writing their reasoning behind their answer choice.

4.6 Summary

In chapter 4, the results of the two version of DIRECT were presented along with the interview data associated with version 1.0. These results form the foundation with which to answer the research questions presented in Chapter 1. The answers to the research questions will be presented in Chapter 5 along with a discussion of what the results mean and their implications for further study.

Chapter 5

Conclusions

This chapter will begin by addressing the answers to the research questions based on the data presented in Chapter 4. Limitations of the instruments and study will follow this discussion. Recommendations for the use of the instrument and results will be considered. Finally, suggestions for future research will be made.

5.1 Research Question 1: Can a multiple-choice exam be used reliably to determine students' ideas about simple circuits?

To answer this question, one first needs to determine if the test is reliable. Reliability coefficients for both versions of DIRECT indicate that the tests are reliable for group measurements. Version 1.1 was also given to a group of students at North Carolina State University prior to and following instruction. The Pearson-Product correlation was found to be .61. This value gives evidence of how stable the test scores are over time. There is approximately a one month delay between pre- and post-instruction assessment.

In analyzing the sources of error variance for DIRECT version 1.1, 30% can be accounted for by content sampling (1 - KR-20 value) and an additional 39% from time sampling (1 - Pearson-Product correlation). Thus, 69% of the variation (content plus time sampling) comes from error variance and 31% from true variance (1 - total measured error variance).¹ Although this result appears to be very damaging, consider the data that make up this analysis. Students, in general, had low scores on version 1.1. Recall that the average was only 41%. The average difficulty of this version was .41 which indicates a moderately difficult test. Assessment experts typically try to achieve an average of 50% to maximize the spread of scores

¹The procedures are outlined in Anastasi, A. (1988). *Psychological Testing* (6th ed.) (pp. 125-7). New York: Macmillan.

(Doran, 1980, Chpt. 5). These statistics are also geared toward tests where the emphasis is on how well students did as opposed to uncovering student difficulties. In this case, low values may provide evidence that the test *is* able to reveal students' misconceptions.

Is the exam a valid measure of student's concepts? Several approaches were used to provide evidence of the test's validity. These included content and construct validity assessments. The content validity was established via two panels of experts. The results indicate that both version have content validity. Additional evidence of the content validity of DIRECT version 1.1 was found in the improved scores from pre-instruction to post-instruction. The exam obviously covered material that was presented within the course. Student interviews using DIRECT version 1.0 indicated that, in general, students were interpreting the questions correctly and that the exam was eliciting their misconceptions. Results from the factor analysis were very similar to those pairs of questions discussed in 4.1.3 and 4.3.3. Thus, the two versions appear to have factorial or construct validity. Evidence of the test's validity comes from the replication of findings of other research studies. For example, from the interview data, none of the students were found to use the clashing currents model. This is consistent with Shipstone's finding that less than 10% of students age 17 use this model.

DIRECT versions 1.0 and 1.1 appear to be both reliable and valid and to pick up student misconceptions. Thus, one can gain information of students' understanding and reasoning about circuit phenomena via multiple-choice testing.

5.2 Research Question 2: What conceptual models are students using to answer the proposed problems?

Data gathered from individual student interviews form the basis for answering this question. Additional evidence can be gleaned from the answer selections made on the two multiple-choice versions of DIRECT. Table 4.14 showed the classification of each of the students' answers across the 10 questions. None of the students were found to use a single

model in answering all ten of the questions. Different questions triggered different models. This finding is similar to those of other researchers (Heller & Finley, 1992; McDermott & Shaffer, 1992; Shipstone, 1984a; Steinberg & Sabella, 1997).

Table 4.14 shows that for any particular question, individual groups of students used different models. Consider question 29, for example, several students reasoned via battery as a constant current source (2), local reasoning (12), and sequential reasoning (17). A couple of students used resistive superposition (15). There are two exceptions, questions 8 and 28. Students either reasoned correctly or reasoned that current was consumed on question 8. For question 28, students reasoned correctly or confused the terms current and voltage. These two questions were simple, series circuits. The questions pertained only to the circuit that was shown. Many of the other questions asked students to compare the behavior of one circuit to another or compare the behavior of a circuit before and after a change was made. These questions require a more complex analysis than do simple, series circuits like those in questions 8 and 28. Thus, providing a greater opportunity for misconceptions to emerge.

There appears to be no discernible pattern to the models students select for particular questions. However, if one examines the relationship between the dominant misconception and the global objective for the question, there is a pattern. Questions 15, 16, 28, and 29 fall under the voltage objective. The dominant misconceptions for these questions are: battery as a constant current source, battery superposition, term confusion I/V , and local reasoning. Most of these misconceptions relate to the function of the battery and what the battery supplies to the circuit. Question 23 deals with resistance. The main misconception used is term confusion between current and resistance. Question 22 deals with interpretation of circuit diagrams and physical aspects of DC resistive circuits. The main misconception here is the number and the location of the contacts for a light bulb. So the misconceptions that students have may appear to differ with each question, but on further examination reveal that students are choosing misconceptions related to aspects of the objective of the question.

Appendix H provides information on the various misconceptions that can be found on the multiple-choice versions of DIRECT. This information can be compared to the data obtained during the interviews by comparing Appendix H with Table 4.12.

5.3 Research Question 3: How are individual differences in gender and in course level affecting the results?

As the results presented in 4.14, 4.23, and 4.34 indicate, there are differences associated with gender in terms of performance, number of misconceptions used, and confidence and with course level with regard to performance and confidence. Generally, males outperformed females and had more confidence in their responses than did females. Females tended to use more misconceptions. Performance differences were found on the two versions of DIRECT with university students outperforming high school students. University students also had more confidence in their answer selections. What reasons might account for these discrepancies?

Lack of scientific experiences may be a main cause for the female students lower performance and increased use of misconceptions. Research indicates that females typically have fewer experiences with science phenomena than do males. Females are often relegated to stenographer as opposed to primary researcher (Good & Brophy, 1994, p. 338; Jones & Wheatley, 1989). "Socialization differences may provide girls with a relatively impoverished knowledge base for activities relevant to [circuit phenomena]" (Lynne Baker-Ward, personal communication, May, 6, 1997). If female students are not having the same scientific experiences as male students, then this may account for the increased use of misconceptions by the females.

During the interviews, females tended to indicate less confidence with their answer selection than did the male students. This result may be the effect of the students' views regarding success. Research indicates that females tend to attribute success with effort while males tend to attribute success with aptitude (Beale, 1994, p. 145).

Time available for covering the material may have been a partial influence in producing the lower scores for the high school students. The high school teachers with whom the researcher has spoken indicated that this topic is often not covered as extensively as they would like. It is left to the end of the school year and is covered in a relatively short amount of time. Thus, not only are some topics given short shrift but students' may not be as attentive. At the university level, circuits are usually covered in the second month of the semester. Thus, there are no time constraints or other distractions. Additionally, some of the university students may have had physics in high school and are, thus, seeing the material for a second time. This familiarity on the part of the university students may have positively influenced their scores.

5.4 Research Question 4: Do the results reveal any unknown misconceptions or provide additional insights into possible explanations for the existing misconceptions?

One aspect of DIRECT that sets it apart from other tests that have been developed is the use of batteries connected in series or parallel. This inclusion allows one to investigate how students interpret voltage and current in circuits containing these elements. Results from version 1.0 indicated that students had difficulty predicting the resulting voltage and current. Interviews indicated that some of the students were using superposition reasoning while others were using either a combination of battery as a constant current source and local reasoning or equations to calculate the equivalent voltage via equivalent capacitance or resistance formulas. Version 1.1 explored further distinctions between two batteries in series and two batteries in parallel through questions 3 and 7 (refer to figures 4.24 and 4.25). Results from these questions indicated the following:

- 1) Students believing that two batteries in parallel provide more energy (27%) also believe that they provide more voltage (21%). (Pearson $r = .37$)
- 2) Students believing that two batteries in series provide more energy (46%) also believe that they provide more voltage (51%). (Pearson $r = .45$)

- 3) Students believing that two batteries in series and two batteries in parallel provide the same energy (17%) also believe that they provide same voltage (22%). (Pearson $r = .41$)

These questions containing multiple batteries were items questioned by both panels of experts. They were concerned that this might diminish the results of the test because multiple batteries are not typically taught. However, the ideas necessary to analyze these circuits are presented in most courses. The ideas are that (a) voltages in parallel remain the same while currents in parallel branches add to equal the total current available and (b) voltages in series add to equal the total input from the battery while current remains the same. These ideas are used in a number of the problems and were acknowledged by the panel of experts as important to include on the exam. Thus, if students truly understand these concepts, they should be able to apply them to novel situations.

Although many of the results that have been obtained through this project are not new, they do provide additional evidence of the existence and persistence of student difficulties with electric circuit phenomena. The following section will summarize some of the other findings from this project.

5.5 Summary of major findings

Many of the results that will be presented in this section replicate the findings of studies discussed in-depth in chapter 2. These findings provide additional evidence of the content validity of the two versions of DIRECT as well as the continued persistence of these misconceptions in the classroom.

Students were able to translate easily from a “realistic” representation of a circuit to the corresponding schematic diagram. Students had difficulty making the reverse translation. However, this result may be more indicative of their difficulty identifying shorts within circuits or of deficiencies in their knowledge regarding the contacts for light bulbs.

Interview results indicated that students use the idea that the battery is a constant current source most often in solving problems. Students were found to use different misconceptions depending on the problem presented. Thus, different questions cued different misconceptions. Although students tend to use different misconceptions for each question presented, they do tend to use misconceptions associated with the global objective of the question.

A comparison of students' definitions of terms used on DIRECT and the student misconceptions indicates that the main source of the difficulty is with term confusion, generally associated with current. Students assign the properties of energy to current, then assign these properties to voltage and resistance. Specifically, both voltage and resistance can only occur in the presence of a current.

Results indicate that students do not have a clear understanding of the underlying mechanisms of electric circuits. This is most likely the result of a weak connection between electrostatics and electrokinetics phenomena since this connection is only now beginning to be addressed in some of the newer textbooks.

Some of the questions require students to analyze simultaneous changes in the variables, like voltage and resistance or current and voltage. Other questions require that students be proficient in their use of ratios (Arons, 1990, pp. 3-6). Results indicate that students can have difficulty with these analyses at times. Results from interviews indicate students' preference for and reliance on formulas. Additionally, students tend to use current as their primary concept in analyzing changes in the circuits.

5.6 Limitations of this study and its associated instruments

This study used a combination of two techniques, multiple-choice testing and individual interviews. It was hoped that the combination would capitalize on the strengths of each method while minimizing their weaknesses. However, problems were still found to exist.

Let us examine the samples that were used. Sample 1 was used to determine the distracters for the multiple-choice version. The university class was taught by someone teaching for the first time. The students in the high school classes were given the test while their regular instructor was away. A few of the tests that were returned showed evidence that the student had not taken the exam seriously. Cartoon drawings and derogatory comments about the test were made. These tests were removed from the sample. Samples 2 and 3 were obtained from a message posted to a listserv which was formed by highly motivated instructors wishing to improve their teaching methods and practicing physics education researchers. Thus, the results from these samples may be higher than the average population. Two of the tests from Sample 3 had to be excluded from the analysis. One test was not completed at all and the other only had the first six questions answered. An additional problem with Sample 3 is the data collected from Germany. The test had to be translated into German so this may confound the results that were obtained. This could explain the poorer performance of the German students compared with the United States and Canada. Students that were selected to participate in the interviews were from the Raleigh, NC area. All of the high school students were in the advanced placement course. Again, their results may be expected to be better than for students in the regular physics course.

The interviews were all conducted by the author. Thus, there is the potential for biasing the data and analysis toward finding particular misconceptions. The latter is partially countered by a second researcher categorizing a sub-sample of the students interviewed. Although I tried to avoid leading the students during the interviews, a few instances were noted (three or four) in transcribing the audio tapes that indicated otherwise. Additionally, it was found that opportunities for deeper probing of particular students reasoning were lost on several occasions. In interviewing the high school students, it was evident that they had difficulty expressing the reasoning behind their answer choices. Thus, some of the information that could have been gained from these particular interviews is lost.

As Redish, Saul, and Steinberg (1997) note, "they [multiple-choice tests] have a tendency to overestimate the student's learning since they can sometimes be answered correctly by means of incorrect reasoning or by 'triggered' responses that fail to represent functional understanding" (p. 47). Results from the interviews indicate that this is true for version 1.0 of DIRECT. Interview results indicate that students changed their answer from their multiple-choice answer an average of 33% of the time while moving toward the correct answer only 42% of the time. In some cases, students chose the correct multiple-choice alternative but had incorrect reasoning. As has been noted in other sections of this dissertation, students can correctly answer questions 10 and 15 but can do so through incorrect reasoning. Additional problems of a more specific nature relating to the two versions of DIRECT will not be discussed since these have previously been discussed in section 4.5.

5.7 Implications and suggestions for further study

Having just discussed the limitations of this study, what are the relevant implications for its results? Albeit that the samples that have been used in this study may appear to limit the strength of the results, consider the results themselves. If students who are taking classes under instructors that are highly motivated and are involved in education research can have these ideas, why cannot students in other classes as well?

How might one use DIRECT? There are two purposes for which DIRECT would be appropriate. The first involves assessing students' reasoning about electric circuit phenomena to determine what misconceptions the group has. The results would allow the classroom instructor to adjust the curriculum as necessary to accommodate the needs of the students. The second use would be as a research tool to determine the effects of curricular material or new teaching methods on students' misconceptions. Evidence for this use can be seen in the ANOVA and t -test results. t -test results using data from version 1.0 indicated that students using the new Chabay and Sherwood text outperformed students using traditional, calculus-

based texts. ANOVA results from data gathered using DIRECT version 1.1 indicated that students using the Physics by Inquiry materials outperformed both the calculus-based and the algebra-based students. t-test results from data collected in 1997 and 1996 using version 1.1 indicate that students using the CASTLE materials outperformed the 1996 sample of high school students.

Further research into why these particular curricular materials seem to result in improvement performance on DIRECT need to be conducted. Aspects that would be important to consider would be the length of time of task, what types of tasks are performed, experience of the instructor using the materials, philosophy of the materials, and the differences and similarities of the materials. These aspects need to be compared between the various curricular packages as well as with traditional methods. At the moment, it is unclear if the apparent improvement is the result of the materials or the increased amount of time spent studying the topic.

The data indicates that there are discrepancies between the performance of males and females in the sample. Efforts to explore the reasons for this gap and that provide ways to close the gap need to be pursued. These differences may in part explain the low numbers of females that take physics. The experiences that females have in taking science courses are obviously different than those that males have. These differences are not just experienced by undergraduates and high school students but by graduate students as well (Windall, 1988). If we wish to have greater numbers of women enrolled in physics and graduating with physics degrees, more work in this area must be undertaken to expose the cause of these differences.

Additional research needs to be undertaken to investigate why students do not use a consistent model of circuit behavior. The explanation of this phenomena may well explain why students have such difficulty with this and other areas of physics.

After the administration of version 1.0 and the accompanying interviews, it became necessary to revise the test. The main incentive for doing this was an attempt to improve the

statistical results. Secondly, there were a few items that needed to be edited to improve their readability. Version 1.0 was very conceptual in nature. There were no numeric calculations to be made, although one could do so by assigning arbitrary values to the variables.

In an attempt to improve the statistical results, more alternatives were added to the test items. This resulted in a group of questions that had a more quantitative nature. However, this approach, upon reflection, was erroneous. In quantifying the questions, the physical nature of light bulbs was neglected. The test items associated the brightness of the bulb directly with power which is incorrect. This problem illustrates the great difficulty one can have in writing quality test questions. One can sometimes construct a very good question which has no physical equivalent. Research into how often this occurs on in-class exams and in textbooks might yield some very interesting results.

The quantification of some items was the main difference between version 1.0 and 1.1. These items resulted in the difference in scores between the two version. Changes to the other items resulted in only minor fluctuates. Version 1.0 is more qualitative and seems to elicit the misconceptions more directly while version 1.1 is more quantitative and seems to elicit the students' mathematical abilities to some extent. If one is more interested in the conceptual understanding of circuits, version 1.0 and newer versions patterned after it would be the better alternative. However, if the students' mathematical abilities are of interest, then version 1.1 would be the choice.

Because of the problems that have been exposed in the development of version 1.1, a new version of the test should be developed and tested. The results should be compared to both version 1.0 and 1.1 for changes in student reasoning. The old versions and the new version should be made available to the physics teaching community so that they may use the test as indicated above.

In closing, I want to stress that DIRECT is not the end-all-be-all of tests. It simply provides another data point for instructors and researchers to use to evaluate the progress of

students' understanding. No one instrument or study can provide the definitive answer. Data regarding students' understanding should be considered like evidence of validity--requiring several measurements through different means to arrive at the final answer.

Bibliography

- (1980). *The Oxford Dictionary of Quotations* (3rd ed.). New York: Book Club Associates.
- (1985-92). *Microsoft Excel* [Macintosh program]. Microsoft (4.0)
- (1986-92). *Canvas* [Macintosh program]. Deneba Systems, Inc. (3.0.6)
- (1989-96). *JMP Statistics Made Visual* [Macintosh program]. Cary, NC: SAS Institute (3.1.6)
- (1994). *PSI-PET Electricity Unit*. AIP-AAPT PSI-PET Project.
- Anastasi, A. (1988). *Psychological Testing* (6th ed.). New York: Macmillan.
- Andre, T., & Ding, P. (1991). Student Misconceptions, Declarative Knowledge, Stimulus Conditions, and Problem Solving in Basic Electricity. *Contemporary Educational Psychology*, **16**(4), 303-13.
- Arnold, M., & Millar, R. (1987). Being constructive: An alternative approach to the teaching of introductory ideas in electricity. *International Journal of Science Education*, **9**(5), 553-63.
- Arons, A. (1977). *The Various Language: An inquiry approach to the Physical Sciences*. New York: Oxford University Press.
- Arons, A. B. (1990). *A guide to introductory physics teaching*. New York: John Wiley & Sons, Inc.
- Ashcraft, M. H. (1989). *Human Memory and Cognition*. USA: HarperCollinsPublishers.
- Ault, C. R., Jr. (1984). Intelligently Wrong: Some Comments on Children's Misconceptions. *Science and Children*, **21**(May), 22-24.
- Baker-Ward, L. (personal communication, May 6, 1997)
- Bauman, R. P., & Adams, S. (1990). Misunderstandings of Electric Current. *The Physics Teacher*, **28**(5), 334.
- Beale, C. R. (1994). *Boys and girls: The development of gender roles*. New York: MacGraw-Hill.
- Beichner, R. J. (1994). Testing student interpretation of kinematics graphs. *American Journal of Physics*, **62**(8), 750-762.
- Benseghir, A., & Closset, J.-L. (1996). The electrostatics-electrokinetics transition: historical and educational difficulties. *International Journal of Science Education*, **18**(2), 179-191.
- Best, J. W. (1981). *Research in Education* (4th ed.). Englewood Cliffs, NJ: Prentice-Hall, Inc.

Brenner, M., Brown, J., & Canter, D. (Ed.). (1985). *The Research Interview: Uses and Approaches*. New York: Academic Press.

Brown, D. (personal communication, March 11, 1997)

Buchweitz, B., & Moreira, M. (1987). Misconceptions in physics: Research findings among Brazilian students. In J. D. Novak (Ed.), *Proceedings of the Second International Seminar on Misconceptions and Educational Strategies in Science and Mathematics, III* (pp. 54-59). Ithaca, NY: Cornell University.

Caillot, M. (1984). Problem Representations and Problem-solving Procedures in Electricity. In R. Duit, W. Jung, & C. von Rhöneck (Eds.), *Aspects of Understanding Electricity, Proceedings of an International Workshop, Ludwigsburg, Germany* (pp. 139-151). Kiel, Germany: Vertrieb Schmidt & Klaunig.

Carlsen, D. D., & Andre, T. (1992). Use of a microcomputer simulation and conceptual change text to overcome student preconceptions about electric circuits. *Journal of Computer-Based Instruction*, *19*(4), 105-9.

Chabay, R., & Sherwood, B. (1995a). *Electric & Magnetic Interactions*. New York: John Wiley & Sons, Inc.

Chabay, R., & Sherwood, B. (1995b). *Instructor's Manual: Electric & Magnetic Interactions*. New York: John Wiley & Sons, Inc.

Closset, J.-L. (1984a). Using Cognitive Conflict to Teach Electricity. In R. Duit, W. Jung, & C. von Rhöneck (Eds.), *Aspects of Understanding Electricity, Proceedings of an International Workshop, Ludwigsburg, Germany* (pp. 267-273). Kiel, Germany: Vertrieb Schmidt & Klaunig.

Closset, J. L. (1984b). Sequential Reasoning in Electricity. In *Research on physics education: proceedings of the first international workshop* (pp. 313-319). La Londe les Maures, France: Editions du Centre National de la Recherche Scientifique.

Cohen, R. (1984). Causal Relations in Electric Circuits: Students' Concepts. In R. Duit, W. Jung, & C. von Rhöneck (Eds.), *Aspects of Understanding Electricity, Proceedings of an International Workshop, Ludwigsburg, Germany* (pp. 107-113). Kiel, Germany: Vertrieb Schmidt & Klaunig.

Cohen, R., Eylon, B., & Ganiel, U. (1983). Potential difference and current in simple electric circuits: A study of student's concepts. *American Journal of Physics*, *51*(5), 407-412.

Cosgrove, M., Osborne, R., & Carr, M. (1984). Children's Intuitive Ideas on Electric Current and the Modification of Those Ideas. In R. Duit, W. Jung, & C. von Rhöneck (Eds.), *Aspects of Understanding Electricity, Proceedings of an International Workshop, Ludwigsburg, Germany* (pp. 247-256). Kiel, Germany: Vertrieb Schmidt & Klaunig.

Cutnell, J. D., & Johnson, K. W. (1995). *Physics* (3rd ed.). New York: John Wiley & Sons, Inc.

Danusso, L., & Dupré, F. (1987). Student representations of simple electric circuits. In J. D. Novak (Ed.), *Proceedings of the Second International Seminar on Misconceptions and Educational Strategies in Science and Mathematics, 3* (pp. 111-115). Ithaca, NY: Cornell University.

- Doran, R. L. (1980). *Basic Measurement and Evaluation of Science Instruction*. Washington, DC: National Science Teachers Association.
- Duit, R. (1984). The Meaning of Current and Voltage in Everyday Language and Its Consequences for Understanding the Physical Concepts of the Electric Circuit. In R. Duit, W. Jung, & C. von Rhöneck (Eds.), *Aspects of Understanding Electricity, Proceedings of an International Workshop, Ludwigsburg, Germany* (pp. 205-214). Kiel, Germany: Vertrieb Schmidt & Klaunig.
- Duit, R. (1984). Students' Representations of the Topological Structure of the Simple Electric Circuit. In R. Duit, W. Jung, & C. von Rhöneck (Eds.), *Aspects of Understanding Electricity, Proceedings of an International Workshop, Ludwigsburg, Germany* (pp. 83-93). Kiel, Germany: Vertrieb Schmidt & Klaunig.
- Dupin, J.-J., & Johsua, S. (1987). Conceptions of French Pupils Concerning Electric Circuits: Structure and Evolution. *Journal of Research in Science Teaching*, **24**(9), 791-806.
- Dupin, J. J., & Johsua, S. (1989). Analogies and "Modeling Analogies" in Teaching: Some Examples in Basic Electricity. *Science Education*, **73**(2), 207-24.
- Dykstra, D. I., Jr., Boyle, C. F., & Monarch, I. A. (1992). Studying Conceptual Change in Learning Physics. *Science Education*, **76**(6), 615-652.
- Evans, J. (1978). Teaching electricity with batteries and bulbs. *The Physics Teacher*, **16**(1), 15-22.
- Eylon, B.-S., & Ganiel, U. (1990). Macro-micro relationships: the missing link between electrostatics and electrodynamics in students' reasoning. *International Journal of Science Education*, **12**(1), 79-94.
- Farnham-Diggory, S. (1992). *Cognitive processes in education* (2nd ed.). New York: HarperCollins.
- Feher, E. (1983). Identification of certain preconceptions that hinder science learning: examples involving electric circuits. In H. Helm & J. D. Novak (Ed.), *Proceedings of the International Seminar on Misconceptions in Science and Mathematics*, (pp. 328-334). Ithaca, NY: Cornell University.
- Fredette, N., & Lochhead, J. (1980). Student conceptions of simple circuits. *The Physics Teacher*, **18**(March), 194-8.
- Fredette, N. H., & Clement, J. J. (1981). Student Misconceptions of an Electric Circuit: What Do They Mean? *Journal of College Science Teaching*, **10**(Mar), 280-85.
- Gauld, C. F. (1988). The cognitive context of pupils' alternative frameworks. *International Journal of Science Education*, **10**(3), 267-74.
- Good, T. L., & Brophy, J. E. (1994). *Looking in Classrooms* (6th ed.). New York: HarperCollins.
- Gott, R. (1984a). The Place of Electricity in the Assessment of Performance in Science. In R. Duit, W. Jung, & C. von Rhöneck (Eds.), *Aspects of Understanding Electricity, Proceedings of an*

- International Workshop, Ludwigsburg, Germany* (pp. 49-61). Kiel, Germany: Vertrieb Schmidt & Klaunig.
- Gott, R. (1984b). Predicting and Explaining the Operation of Simple DC Circuits. In R. Duit, W. Jung, & C. von Rhöneck (Eds.), *Aspects of Understanding Electricity, Proceedings of an International Workshop, Ludwigsburg, Germany* (pp. 63-72). Kiel, Germany: Vertrieb Schmidt & Klaunig.
- Grayson, D. J. (1994). Concept Substitution: An Instructional Strategy for Promoting Conceptual Change. *Research in Science Education*, **24**, 102-111.
- Grob, K., Pollack, V. L., & Rhöneck, C. v. (1991). Computerized analysis of students' ability to process information in the area of basic electricity. In F. G. Reinders Duit Hans Niedderer (Ed.), *Proceedings of the Research in Physics Learning: Theoretical Issues and Empirical Studies*, (pp. 296-309). University of Bremen: The Institute for Science Education at the University of Kiel.
- Gutwill, J., Frederiksen, J., & Ranney, M. (1996). Seeking the causal connection in electricity: shifting among mechanistic perspectives. *International Journal of Science Education*, **18**(2), 143-162.
- Hammer, D. (1996). More than misconceptions: Multiple perspectives on student knowledge and reasoning, and an appropriate role for education research. *American Journal of Physics*, **64**(10), 1316-1325.
- Harmon, M. (1993). Going Beyond the Written Word - what performance assessment can tell us about concept understanding. In *Proceedings of the Third International Seminar on Misconceptions and Educational Strategies in Science and Mathematics*, . Ithaca, NY: Misconceptions Trust.
- Härtel, H. (1984). The Electric Circuit as a System. In R. Duit, W. Jung, & C. von Rhöneck (Eds.), *Aspects of Understanding Electricity, Proceedings of an International Workshop, Ludwigsburg, Germany* (pp. 343-352). Kiel, Germany: Vertrieb Schmidt & Klaunig.
- Heller, P. M., & Finley, F. N. (1992). Variable Uses of Alternative Conceptions: A Case Study in Current Electricity. *Journal of Research in Science Teaching*, **29**(3), 259-75.
- Helm, H., & Jiya, Z. (1993). Students' Understanding of the concept of "current": Language, models, definitions. In *Proceedings of the The Proceedings of the Third International Seminar on Misconceptions and Educational Strategies in Science and Mathematics*, . Ithaca, NY: Misconceptions Trust.
- Hestenes, D., & Wells, M. (1992). A Mechanics Baseline Test. *The Physics Teacher*, **30**(March), 159-66.
- Hestenes, D., Wells, M., & Swackhamer, G. (1992). Force Concept Inventory. *The Physics Teacher*, **30**(March), 141-58.
- Huffman, D., & Heller, P. (1995). What Does the Force Concept Inventory Actually Measure? *The Physics Teacher*, **33**(March), 138-143.

- Johnstone, A. H., & Mughol, A. R. (1978). The concept of electrical resistance. *Physics Education*, **13**, 46-49.
- Johsua, S. (1984). Students' interpretation of simple electrical diagrams. *European Journal of Science Education*, **6**(3), 271-275.
- Johsua, S., & Dupin, J. J. (1984). Schematic diagrams, representations and type of reasoning in basic electricity. In R. Duit, W. Jung, & C. von Rhöneck (Eds.), *Aspects of Understanding Electricity, Proceedings of an International Workshop, Ludwigsburg, Germany* (pp. 129-138). Kiel, Germany: Vertrieb Schmidt & Klaunig.
- Jones, M. G., & Wheatley, J. (1989). Gender influences in classroom displays and student-teacher behaviors. *Science Education*, **73**(5), 535-545.
- Jung, W. (1984). Category Questionnaires - The Technique and Some Results. In R. Duit, W. Jung, & C. von Rhöneck (Eds.), *Aspects of Understanding Electricity, Proceedings of an International Workshop, Ludwigsburg, Germany* (pp. 197-204). Kiel, Germany: Vertrieb Schmidt & Klaunig.
- Kärrqvist, C. (1984). The Development of Concepts by Means of Dialogues Centred on Experiments. In R. Duit, W. Jung, & C. von Rhöneck (Eds.), *Aspects of Understanding Electricity, Proceedings of an International Workshop, Ludwigsburg, Germany* (pp. 215-226). Kiel, Germany: Vertrieb Schmidt & Klaunig.
- Kärrqvist, C. (1987). Pupils are able. In J. Novak (Ed.), *Proceedings of the Second International Seminar on Misconceptions and Educational Strategies in Science and Mathematics, III* (pp. 293-96). Ithaca, NY: Cornell University: Cornell University.
- Kline, P. (1986). *A handbook of test construction: introduction to psychometric design*. New York: Methuen.
- Lea, S. M., Thacker, B. A., Kim, E., & Miller, K. M. (1994). Computer-assisted assessment of student understanding in physics. *Computers in Physics*, **8**(1), 122-127.
- Licht, P. (1991). Teaching electrical energy, voltage and current: an alternative approach. *Physics Education*, **26**(Sep), 272-77.
- Licht, P., & Thijs, G. D. (1990). Method to trace coherence and persistence of preconceptions. *International Journal of Science Education*, **12**(4), 403-416.
- Maichle, U. (1981, September). *Representation of Knowledge in Basic Electricity and Its Use for Problem Solving*. Paper presented at the meeting of the Problems concerning students' representational of physics and chemistry knowledge, Ludwigsburg, Germany.
- McDermott, L. C., & Shaffer, P. S. (1992). Research as a guide for curriculum development: An example from introductory electricity. Part I: Investigation of student understanding. *American Journal of Physics*, **60**(11), 994-1003.
- McDermott, L. C., & van Zee, E. H. (1984). Identifying and Addressing Student Difficulties with Electric Circuits. In R. Duit, W. Jung, & C. von Rhöneck (Eds.), *Aspects of Understanding*

- Electricity, Proceedings of an International Workshop, Ludwigsburg, Germany* (pp. 39-48). Kiel, Germany: Vertrieb Schmidt & Klaunig.
- Mehrens, W. A., & Lehmann, I. J. (1991). *Measurement and evaluation in Education and Psychology* (4th ed.). Philadelphia: Holt, Rinehardt and Winston.
- Métioui, A., Brassard, C., Levasseur, J., & Lavoie, M. (1996). The persistence of students' unfounded beliefs about electrical circuits: the case of Ohm's law. *International Journal of Science Education*, **18**(2), 193-212.
- Millar, R., & Beh, K. L. (1993). Students' understanding of voltage in simple parallel electric circuits. *International Journal of Science Education*, **15**(4), 351-361.
- Millar, R., & King, T. (1993). Students' understanding of voltage in simple series electric circuits. *International Journal of Science Education*, **15**(3), 339-349.
- Monk, M. (1990). A Genetic Epistemological Analysis of Data on Children's Ideas about DC Electrical Circuits. *Research in Science and Technological Education*, **8**(2), 133-43.
- Nichols, R. (1985). *Multiple Analysis Program System User's Manual*. Amherst, NY: MAPS & Co.
- Nitko, A. J. (1983). *Educational tests and measurement: an introduction*. New York: Harcourt Brace Jovanovich.
- Osborne, R. (1981). Children's Ideas about electric current. *New Zealand Science Teacher*, **29**, 12-19.
- Osborne, R. (1983). Towards Modifying Children's Ideas about Electric Current. *Research in Science and Technological Education*, **1**(1), 73-82.
- Picciarelli, V., Di Gennaro, M., Stella, R., & Conte, E. (1991a). A Study of University Students' Understanding of Simple Electric Circuits Part 1: Current in d.c. Circuits. *European Journal of Engineering Education*, **16**(1), 41-56.
- Picciarelli, V., Di Gennaro, M., Stella, R., & Conte, E. (1991b). A Study of University Students' Understanding of Simple Electric Circuits Part 2: Batteries, Ohm's Law, Power Dissipated, Resistors in Parallel. *European Journal of Engineering Education*, **16**(1), 57-71.
- Psillos, D., Koumaras, P., & Tiberghien, A. (1988). Voltage presented as a primary concept in an introductory teaching sequence on DC circuits. *International Journal of Science Education*, **10**(1), 29-43.
- Psillos, D., Koumaras, P., & Valassiades, O. (1987). Pupils' Representations of Electric Current before, during and after Instruction on DC Circuits. *Research in Science and Technological Education*, **5**(2), 185-99.
- Redish, E. F., Saul, J. M., & Steinberg, R. N. (1997). On the effectiveness of active-engagement microcomputer-based laboratories. *American Journal of Physics*, **65**(1), 45-54.

- Russell, T. J. (1980). Children's Understanding of Simple Electrical Circuits. In T. J. Russell & A. P. C. Sia (Eds.), *Pilot Project: Science and Mathematics Concept Learning of Southeast Asian Children - Second Report on Phase Two 1978-1979* (pp. 67-91). Glugor, Penang Malaysia: SEAMEO-RECSAM.
- Sebastià, J. M. (1993). Cognitive mediators and interpretations of electric circuits. In *Proceedings of the Third International Seminar on Misconceptions and Educational Strategies in Science and Mathematics*, . Ithaca, NY: Misconceptions Trust.
- Shaffer, P. S., & McDermott, L. C. (1992). Research as a guide for curriculum development: An example from introductory electricity. Part II: Design of instructional strategies. *American Journal of Physics*, **60**(11), 1003-13.
- Sherwood, B. (personal communication, January 25, 1995)
- Shipstone, D. (1985). Electricity in Simple Circuits. In R. Driver, E. Guesne, & A. Tiberghien (Eds.), *Children's Ideas in Science* Philadelphia, PA: Open University Press.
- Shipstone, D. M. (1984a). A study of children's understanding of electricity in simple DC circuits. *European Journal of Science Education*, **6**(2), 185-198.
- Shipstone, D. M. (1984b). On Children's Use of Conceptual Models in Reasoning about Current Electricity. In R. Duit, W. Jung, & C. von Rhöneck (Eds.), *Aspects of Understanding Electricity, Proceedings of an International Workshop, Ludwigsburg, Germany* (pp. 73-82). Kiel, Germany: Vertrieb Schmidt & Klaunig.
- Shipstone, D. M., von Rhöneck, C., Jung, W., Kärrqvist, C., Dupin, J. J., Johsua, S., & Licht, P. (1988). A study of students' understanding of electricity in five European countries. *International Journal of Science Education*, **10**(3), 303-16.
- Sokoloff, D. R. (1994). *RealTime Physics* Electricity: Active Learning of Electric Circuit Concepts Using Microcomputer-Based Current and Voltage Probes. Paper has been accepted for publication in *La Fisica Nella Scuola*.
- Solomon, J., Black, P., Oldham, V., & Stuart, H. (1985). The pupils' view of electricity. *European Journal of Science Education*, **7**(3), 281-294.
- Steinberg, M. (personal communication, February 3, 1995)
- Steinberg, M. (personal communication, January 28, 1997)
- Steinberg, M. S. (1984). Construction of Causal Models: Experimenting with Capacitor-controlled Transients as a Means of Promoting Conceptual Change. In R. Duit, W. Jung, & C. von Rhöneck (Eds.), *Aspects of Understanding Electricity, Proceedings of an International Workshop, Ludwigsburg, Germany* (pp. 363-373). Kiel, Germany: Vertrieb Schmidt & Klaunig.
- Steinberg, M. S., & Wainwright, C. L. (1993). Using Models to Teach Electricity—The CASTLE Project. *The Physics Teacher*, **31**(Sep), 353-57.
- Steinberg, R. N., & Sabella, M. S. (1997). Performance on Multiple-Choice Diagnostics and Complementary Exam Problems. *The Physics Teacher*, **35**(March), 150-155.

- Stockmayer, S. M., & Treagust, D. F. (1996). Images of electricity: how do novices and experts model electric current? *International Journal of Science Education*, **18**(2), 163-178.
- Tamir, P. (1990). Justifying the selection of answers in multiple choice items. *International Journal of Science Education*, **12**(5), 563-573.
- Thacker, B., Kim, E., Trefz, K., & Lea, S. M. (1994). Comparing problem solving performance of physics students in inquiry-based and traditional introductory physics courses. *American Journal of Physics*, **62**(7), 627-633.
- Tiberghien, A. (1984). Critical review on the research aimed at elucidating the sense that the notions of electric circuits have for students aged 8 to 20 years. In *Research on physics education: proceedings of the first international workshop* La Londe les Maures, France: Editions du Centre National de la Recherche Scientifique.
- Treagust, D. F. (1988). Development and use of diagnostic tests to evaluate students' misconceptions in science. *International Journal of Science Education*, **10**(2), 159-169.
- van Aalst, H. F. (1984). The Differentiation between Connections in Series and in Parallel from Cognitive Mapping; Implications for Teaching. In R. Duit, W. Jung, & C. von Rhöneck (Eds.), *Aspects of Understanding Electricity, Proceedings of an International Workshop, Ludwigsburg, Germany* (pp. 115-128). Kiel, Germany: Vertrieb Schmidt & Klaunig.
- von Rhöneck, C. (1984). The Introduction of Voltage as an Independent Variable - the Importance of Preconceptions, Cognitive Conflict and Operating Rules. In R. Duit, W. Jung, & C. von Rhöneck (Eds.), *Aspects of Understanding Electricity, Proceedings of an International Workshop, Ludwigsburg, Germany* (pp. 275-286). Kiel, Germany: Vertrieb Schmidt & Klaunig.
- von Rhöneck, C., & Grob, K. (1987). Representation and problem-solving in basic electricity, predictors for successful learning. In J. D. Novak (Ed.), *Proceedings of the Second International Seminar on Misconceptions and Educational Strategies in Science and Mathematics*, (pp. 564-77). Ithaca, NY: Cornell University.
- von Rhöneck, C., & Völker, B. (1984). Semantic Structures Describing the Electric Circuit Before and After Instruction. In R. Duit, W. Jung, & C. von Rhöneck (Eds.), *Aspects of Understanding Electricity, Proceedings of an International Workshop, Ludwigsburg, Germany* (pp. 95-106). Kiel, Germany: Vertrieb Schmidt & Klaunig.
- Wandersee, J. H., Mintzes, J. J., & Novak, J. D. (1994). Research on alternative conceptions in science. In D. L. Gabel (Eds.), *Handbook of Research on Science Teaching and Learning* (pp. 177-210). New York: Macmillan Publishing Company.
- White, B. Y., Frederiksen, J. R., & Spoehr, K. T. (To be published). Conceptual Models for Understanding the Behavior of Electrical Circuits. In M. Caillot (Eds.), *Learning Electricity and Electronics with Advanced Educational Technology* New York, NY: Springer Verlag.
- Wiersma, W. (1969). *Research Methods in Education: an introduction*. Philadelphia: J. B. Lippincott.
- Windall, S. E. (1988). AAAS Presidential Lecture: Voices from the pipeline. *Science*, **241**, 1740-1745.

Appendix A
Information obtained from the test sites

Table A.1: Information from the 1995 test sites who used DIRECT version 1.0

Special Code	Institution	Location	Institution type	#S in physics/yr	#S overall/yr	Percentage Female
111001	Northern Kentucky University	Heighland Heights, KY	university	250	12000	30-50%
111003	Dordt College	Sioux Center, IA	college	55	1200	9-27%
111004	Virginia Tech	Blacksburg, VA	college	1500	23000	
111006	Eastern Kentucky University	Richmond, KY	university	425		55%
111007	Miami University - Hamilton Campus	Hamilton, OH	2yr branch of a university		2200	20%
111009	Sandhills Community College	Pinehurst, NC	community college	30	2500	10-25%
111000 A	North Carolina State University	Raleigh, NC	university	5780	26650	
111000 B			university			
111000 C			university			
222001	Rochester Adams HS	Rochester Hills, MI	HS	250	1800	50%
222004	Roosevelt HS	Kent, OH	HS	168	1300	50-55%
222005	Mississippi School for Math and Science	Columbus, MS	HS-2yr residential	250	250	
222007	Catasauqua HS	Catasauqua, PA	HS	30-40	500	50%
222008	Enloe HS	Raleigh, NC	HS			
222003 A	Sycamore HS	Cincinnati, OH	HS	250	400	50%
222003 B			HS			
222003 C			HS			

Table A.1 (Continued)

Special Code	Percentage minority	#yrs teaching	physics background	#S taking DIRECT	time spent on circuits	when unit finished
111001	10-25%	8	PhD	11	1.5 weeks	3/22/95
111003	6%	12	PhD	58	1 week 3 lab periods	alg based mid feb; cal based early dec
111004		25	PhD	455	2 weeks	Mar-95
111006	5-7%	31	BA, MS in physics PhD higher Ed	27	2 weeks including AC	dc 3/1 ac 4/17
111007	0%	18	PhD	6	mixed in with other topics and spread out over 8 wks	4/6/95
111009	5%	15	PhD	11	7 lessons 1.3 hr lab	4/10/95
111000 A			PhD		3 weeks	
111000 B			PhD	27	1 lecture	3rd week in Feb
111000 C			PhD	13	2 weeks	2 weeks prior to 4/12/95
222001	20%	32	MAT in Physics		7 days with one lab	mid April
222004	5%	21	BS in Ed; MS Physics Ed; PhD Educ.	19	4 weeks	Dec. 93&94
222005		25	Chem major Ed.S.	51	14 days	4/20/95
222007		20	BS Ed. MEd	18	3 weeks	6/1/95
222008					3 weeks	end of April
222003 A		20	Physics certification	21	10 days - honors 14 days- reg	3/29 H 4/28 Reg
222003 B		14	Physics certification	104	2-3 weeks	April
222003 C		2	Physics certification	47	2-3 weeks	5-May

Table A.1 (Continued)

Special Code	when DIRECT given	material covered	textbooks used	math background
111001	4/25/95	batteries, current, resistance, current density, series/ circuits effective resistance, Kirchhoff's laws, capacitors	Halliday, Resnick and Walker Fundamentals of Physics 4th ed	cal
111003	cal 4/21 alg 4/24,26	alg - dc simple series, , non-linear resistances, Kirchhoff's laws, capacitance; cal - alg + RL, RLC, AC series RLC circuits	alg. Giancoli Physics 3rd; cal. Halliday Resnick and walker Fundamentals of Physics 4th ed	alg. and cal.
111004	Apr-95	material on circuits from Cutnell and Johnson	Cutnell and Johnson	alg. trig
111006	2-May	C15-21 DC C18 AC C21	Serway and Faughn	alg. trig some with cal
111007	5/4/95	typical batteries and bulbs, exp. lots of discussion of what's happening inside the wires, Ohm's law, Kirchhoff's rules, charging and discharging capacitors, very little with series and circuits	Chabay and Sherwood	cal
111009	4/24/95	capacitance, batteries, current, resistance, resistivity, energy, power, simple circuits, Ohm's law, Kirchhoff's laws	Serway 3rd ed updated Physics for Scientists and Engineers	alg, geometry, cal.
111000 A	after finishing circuits	C5,6,8	Chabay and Sherwood	calculus
111000 B	4/12/95		Cutnell and Johnson 2nd	alg/ trig with some calculus
111000 C	4/12/95	C5,6,7,8,9	Chabay and Sherwood	calculus
222001	16-May	energy, work, ohm's law	Glenco, Principals and Problems by Zitzewitz	alg and cal
222004	Apr-95	electricity as flow of electrons already in conductor, voltage, current, resistance, Ohm's law Joule's law series circuits fuses circuit breakers	Hewitt, 6th ed. Conceptual Physics	alg. pre-cal
222005	5/1/95	ohm's law, simple circuits, cardinal rules for resistance in series and , simple networks, complex networks, Kirchhoff's laws, electric energy and power, cost of electricity	Modern Physics (Holt, Rinehart & Winston) Schaum's College Physics	pre-cal with a few 1st semester cal
222007	6/6/95	adapted labs 5-7 of RealTime Physics for use with multimeters lab 5 - batteries and bulbs lab 6 - current in series/ lab 7 - voltage in series/	Conceptual Physics HS version	alg. trig some cal
222008	5/19/95	potential current resistors capacitors inductors	Halliday & Resnick, Beuche	calc and alg
222003 A	5/3/95	simple circuits series/	Physics: Principles & problems Zitzewitz & Murphy	alg some pre cal
222003 B	5/18/95	series/ Ohm's law, power heat	Physics: Principles & problems Zitzewitz & Murphy	alg. trig. geometry
222003 C	10-May	series/ Ohm's law power electrostatics	Physics: Principles and problems Zitzewitz and Murphy	alg geometry

Table A.2: Information from the 1996 test sites who used DIRECT version 1.1

Special Code	Institution	Type of institution	Location of institution	Overall student population	#S take physics/year
101	Sandhills Community College	Community college	rural	2400	50
102	LaSierra University	4yr private	suburban	1500	100
103	Nebraska Wesleyan University	Private college	suburban	1500	70
104	Eastern Oregon State College	4 yr	rural	1700	75
106	Dordt College	Private 4 yr	rural	1100	80
107	Snow College	State 2yr	rural	2300	450
108	University of Michigan-Dearborn	University	suburban	8000	450
109	Ohio State University at Marion	2 yr regional campus	rural	1100	60
110	UNC Greensboro	University	urban	12000	300
111	Curry College	4 yr private	suburban	1000	10
112	University of Western Ontario	University	city	20000	1500
113	Forsyth Technical Community College	Public two year	urban	3000	210
115	Sandhills Community College	Community College	rural	1800	100
116	US Naval Academy	4 yr College	small city	4000	1000
117	University of Winnipeg Collegiate	Private HS	inner city	550	80
202	Roosevelt HS	Public HS	small city/suburban	1300	160
203	Canisius College	Private Catholic HS	inner city	820	all 8-11th; 30% of 12-13th
210	Gilman School	Private boys, HS	city	400	70

Table A.2 (Continued)

Special Code	Percentage Female	Ethnic Makeup				#yrs. teaching	Physics background
		Percentage Caucasian	Percentage Black	Percentage Asian	Percentage Hispanic		
101	8:01	80	10			15	PhD Physics
102	50					22	Phd
103	38	99				15	BS in physics & math; PhD in astro-geophysics
104	2:01	mostly				14	PhD
106	10:01	96		3		13	PhD
107	1:01	95		5		6	BS MS in Chemical eng.
108	20	80				16	Ms Physics
109	8:1 in engineering; 1:1 else	mostly				26	PhD
110		mostly				30	BA, MS, PhD in Physics
111	2:01	mainly				22	PhD in physics
112						30	Bsc Phd
113	3—1	10 (caucasian):1 (african american)				22	BS and MEd in Science Ed. with Physics concentration
115	4—1	85	10		5	12	BS in physics w/honors, MS in physics
116	6.25—1					1	PhD
117	40					18	BSc Physics MEd
202	1—1	90	5	5		23	MS in Teaching in Physics
203	50					8+	
210	0	70—80	5—10	10—20	0	29	Ph.D. in physics

Table A.2 (Continued)

Special Code	Class 1			
	# S taking DIRECT	Level	Math background	Textbooks
101	14	calc	calc	Serway Physics for Scientists and Engineers
102	43	alg	alg trig	Serway College Physics
103	21	calculus	alg, trig, calc	Hecht: Physics
104	23	alg	alg	Hecht plus some of McDermott's light bulbs and batteries
106	20	calc	calc	Halliday, Resnick, Walker Fundamentals of Physics 4ed
107	17	General 3 qt. algebra based	algebra trig some calc	Serway and Faughn College Physics 4th ed
108	101	cal	cal	Resnick, Halliday and Walker
109	6	calculus based	cal.	his own
110	18	calculus	alg, calc, trig	Serway's Principles of Physics
111	7	algebra based	algebra and trig	his own textbook
112	100	engineering	calculus	University Physics Benson
113	6	algebra based	algebra trig	Giancoli Physics 4 ed
115	12	algebra based	algebra & trig	Principles of Physics Ohanian
116	24	Calculus based	Calculus	Halliday, Resnick, and Walker
117	18	General	Algebra	Martindale, Heath, Eastman Fundamentals of Physics
202	47	General Intro	algebra	Conceptual Physics 6th ed Hewitt
203	3 classes: 27, 32, and 28			
210	2 classes: 18 and 17	9th grade physical science	basic algebra	Prentice-Hall Physical Science

Table A.2 (Continued)

Special Code	Class 2			
	# S taking DIRECT	Level	Math background	Textbooks
101				
102				
103				
104				
106				
107				
108				
109	23	inquiry	missing	McDermott Physics by Inquiry
110				
111				
112				
113				
115				
116	22	Calculus based	Calculus	Halliday, Resnick, and Walker
117	2 classes: 27 and 10	General	Algebra	Martindale, Heath, Eastman Fundamentals of Physics
202				
203				
210	2 classes: 16 and 10	General physics algebra based	algebra basic trig	Taffel: Physics It's Methods and Meanings

Table A.2 (Continued)

Special Code	Topics covered
101	Capacitors, simple circuits, kirchhoff's rules
102	electric potential, electric current, resistivity, resistance, temp var of R, electric energy, power, sources of emf, series and parallel R's simple and complex, Kirchhoff's rules
103	Followed "Workshop Physics II" Activity guide
104	Coulomb's law, electric field, DC circuits
106	DC series, parallel combinations, non-linear resistances, measurement devices, Kirchhoff's laws, power, capacitance, in AC: inductors, RLC series circuits, power
107	Capacitance, combination of capacitors, dielectrics, energy stored, current drift speed, resistance, resistivity, temp dependence, Ohm's law, combinations of resistors, power, household circuits, safety, Kirchhoff's rules, RC circuits
108	CD circuits with resistors and bulbs, series, parallel, series and parallel combinations, DC circuits with capacitance, RC circuits
109	#1: potential, pot. diff, current, resistance, resistivity, capacitance, inductance, Ampere's law, Faraday's law, Law of Biot Savart, RC, RL, RLC circuits #2: voltage, current, resistance
110	DC circuits, capacitance, inductance
111	underlying model, transient circuits, resistors, capacitors, series and parallel circuits, power
112	Ohm's law, Kirchhoff, conductors, batteries, resistors, capacitors, voltmeters, ammeters, Wheatstone bridge
113	Ohm's law, power, series and parallel, resistivity
115	Ohm's law, circuit reduction, series and parallel circuits, capacitors
116	Resistance, capacitance, emfs, current, Ohm's law, circuit rules (loop rule, emf rule)
117	Sources of emf, V, I, R, Ohm's law, resistivity, power, simple series & parallel networks
202	Ohm's law, resistance, electric power, series and parallel circuits
203	
210	current, simple circuits, voltage, pot. diff., resistance, series and parallel circuits, fundamentals of house wiring, power, energy Physics only: series-parallel combinations, internal resistance of source

Table A.2 (Continued)

Special Code	When finished circuits	Time spent on circuits	Date DIRECT given
101	15-Apr	8 contact hrs	15-Apr
102	16-Feb	9 50 min. lectures, 1 3 hr. lab	20-Feb
103	1-Apr	8 2-hr sessions	6-May
104	17-May	5 weeks	4-Jun
106	Dec-95	1 week in class 4 weeks in lab	1-Mar
107	7-Mar	12 days	8-Mar
108	27-Feb	3 weeks	6-Mar
109	#1:2/29 #2:3/6	#1 4 weeks for everything listed in topics #2 9 weeks	12-Mar
110	2-Feb	3 lecture periods and 2 3hr labs	19-Feb
111	10-Apr	3-4 weeks	22-Apr
112	6-Mar	2 weeks	11-Mar
113	22-Apr	12 hours	29-Apr
115	2 weeks ago	2 weeks	25-Apr
116	10 days ago	5-7 classes	12-Mar
117	1-Feb	5 weeks	27-Mar
202	Jan-96	6 days	Mar-96
203	6 weeks ago	2 weeks	2/29/96
210	9th grade 3/25 physics 4/10	1.5 - 2 weeks	9th 4/4 physics 5/1

Appendix B
High school and University Textbooks and Laboratory Manuals

Textbooks

Arons, A. B. (1990). *A Guide to Introductory Physics Teaching*. New York, NY: John Wiley & Sons, Inc.

Ouseph, P. J. (1986). *Technical Physics* (2nd ed.). New York, NY: John Wiley & Sons, Inc.

Kuhn, K. F. & Faughn, J. S. (1980). *Physics in Your World* (2nd ed.) Philadelphia, PA: Saunders Golden Sunburst Series.

Cutnell, J. D. & Johnson, K. W. (1992). *Physics* (2nd ed.). New York, NY: John Wiley & Sons, Inc.

Serway, R. A. and Faughn, J. S. (1985). *College Physics*. New York, NY: Saunders College Publishing

Sears, F. W., Zemansky, M. W. and Young, H. D. (1982). *University Physics* (6th ed.). Reading, Mass: Addison-Wesley Publishing Co.

Tipler, P. A. (1982). *Physics* (2nd ed.). New York, NY: Worth Publisher's Inc.

Griffith, W. T. (1992). *The Physics of Everyday Phenomena: A Conceptual Introduction to Physics*. Dubuque, IA: Wm. C. Brown Publishers

Hewitt, P. G. (1993). *Conceptual Physics* (7th ed. College version). New York, NY: Harper Collins College Publishers

Laboratory manuals

Murphy, J. T. (1982). *Laboratory Physics*. Columbus, OH: Charles E. Merrill Publishing Co.

(1992). *Heath Physics Laboratory Manual* (Teacher's Edition). D.C. Heath and Company

Taffel, A., Baumel, A. & Landecker, L. (1992). *Physics: Its Methods and Meaning Laboratory Manual* (6th ed.). Englewood Cliffs, NY: Prentice Hall

Zitzewitz, P. and Kramer, C. (1990). *Merrill Physics: Principles and Problems Laboratory Manual* (Teacher's Edition). Columbus, OH: Merrill

Robinson, P. (1992). *Conceptual Physics, Laboratory Manual* (Teacher's Edition). New York, NY: Addison-Wesley Publishing Company

Physics 231 Laboratory manual, North Carolina State University

Kuhn, K. F. (1987). *Physics in your lab* (4th ed.). Eastern Kentucky University

Elementary Physics 132 Laboratory manual (4th ed.). Physics Department, Eastern Kentucky University

Teague, C. D. *Physics 202 Laboratory Manual*. Physics Department, Eastern Kentucky University

Textbooks

Hewitt, P. G. (1987). *Conceptual Physics* (Teacher's edition, HS version). Reading, Mass: Addison-Wesley Publishing Company, Inc.

Haber-Schaim, Dodge, & Walter (1986). *PSSC Physics* (6th ed.). Lexington, Mass: D.C. Heath & Company

Cutnell, J. D. & Johnson, K. W. (1995). *Physics* (3rd ed.). New York, NY: John Wiley & Sons, Inc.

Laboratory manuals

Johnston, K. L. & Egler, R. A. (1992). *Exploring Experimental Physics* (3rd ed.) Apex, NC: Contemporary Publishing Company

Owen, H. L. & Patty, R. R. (1983). *General Physics Laboratory Manual* (4th ed.). Raleigh, NC: Contemporary Publishing Company

Robinson, Paul (1993). *Conceptual Physics, Laboratory Manual*. New York, NY: Harper Collins College Publishers

Appendix C
Open-ended version of DIRECT

Diagnosing Resistive Direct Current Electric Circuits Concepts

Name _____ Class/Period _____

School Noblesville Senior High School Gender _____ Age _____

Directions: All light bulbs, resistors, and batteries should be considered identical unless you are told otherwise. In addition, the battery is to be assumed ideal, that is to say, the internal resistance of the battery is negligible. Please thoroughly explain your answers to all questions.

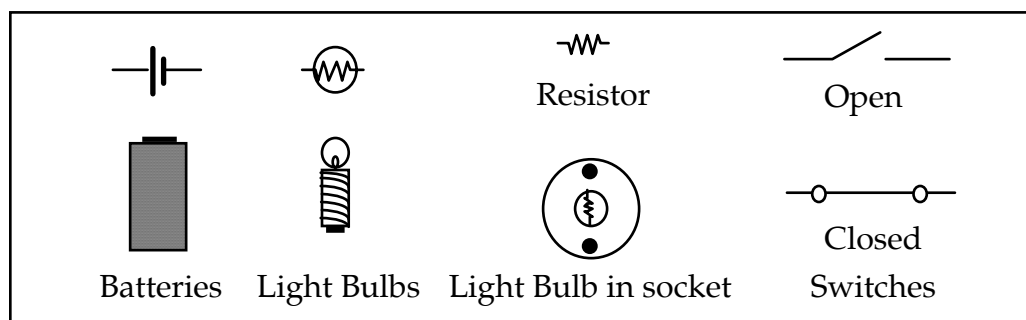

- 1) Are charges used up in a light bulb, being converted to light? Explain your reasoning.

- 2) How does the power delivered to resistor A change when resistor B is added as shown in circuits 1 and 2 respectively?

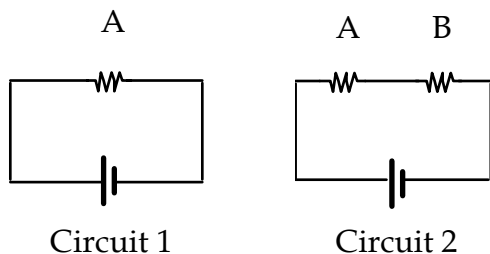

3) Rank the energy delivered each second to the light bulbs shown in the circuits below from lowest to highest.

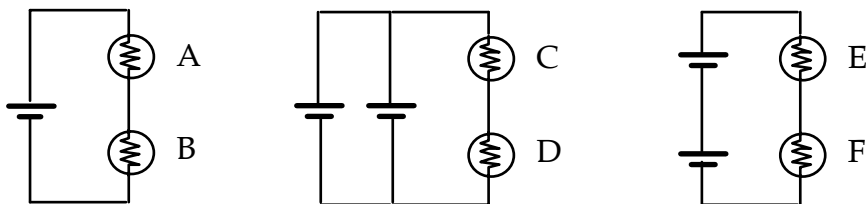

4) Which circuit(s) below represent(s) a circuit consisting of two light bulbs in parallel with a battery?

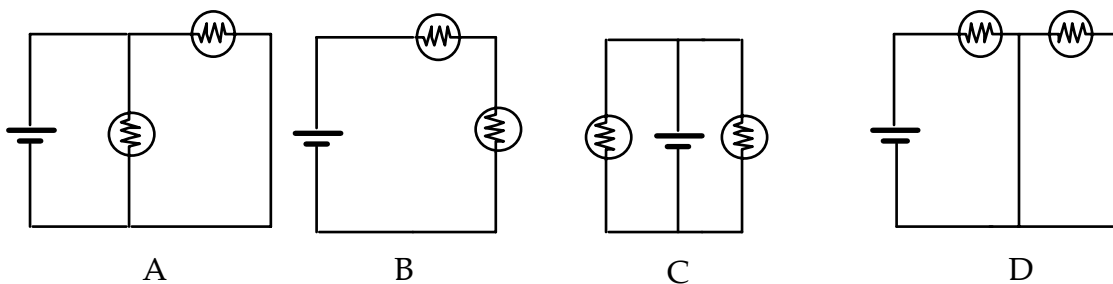

5) Compare the resistance of branch 1 with that of branch 2. Which has the least resistance?

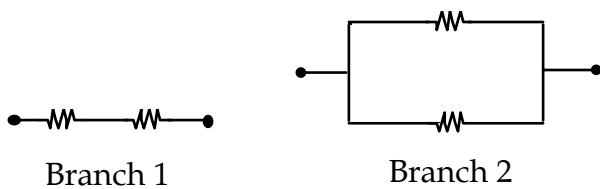

6) Rank the potential difference between points 1 and 2, points 3 and 4, and points 4 and 5 in the circuit shown below from highest to lowest.

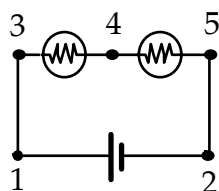

7) Compare the brightness of the bulb in circuit 1 with that in circuit 2. Which bulb is brighter?

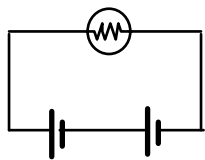

Circuit 1

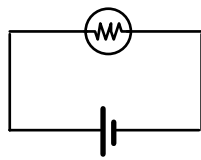

Circuit 2

8) Compare the current at point 1 with the current at point 2. Which point has the larger current?

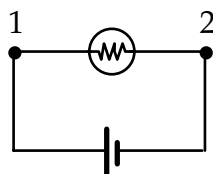

9) Which circuit(s) will light the bulb?

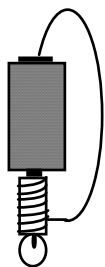

A

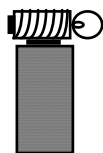

B

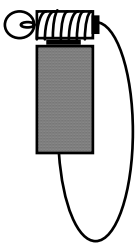

C

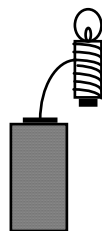

D

- 10) Compare the brightness of bulbs A and B in circuit 1 with the brightness of bulb C in circuit 2. Which bulb is the brightest?

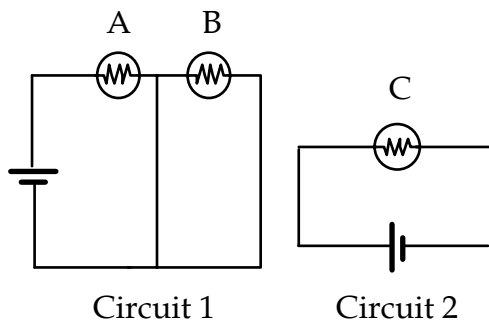

- 11) Why do the lights in your home come on almost instantaneously?

- 12) Rank the power delivered to the top resistor in each of the circuits shown below from lowest to highest.

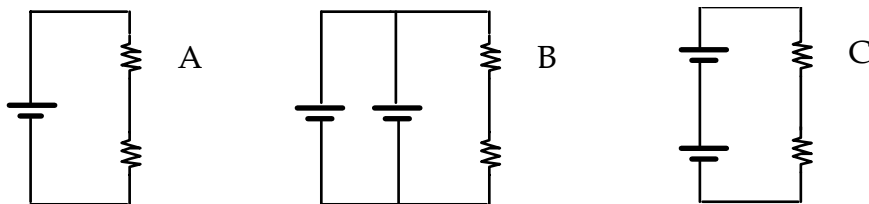

13) Which schematic diagram(s) represent(s) the realistic circuit shown below?

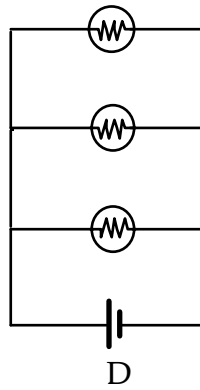
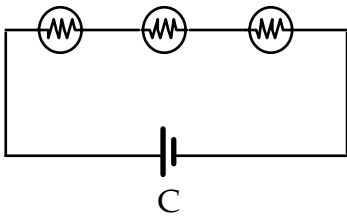
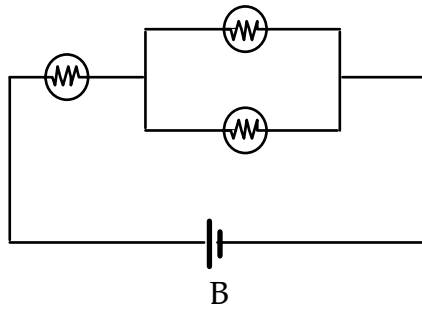
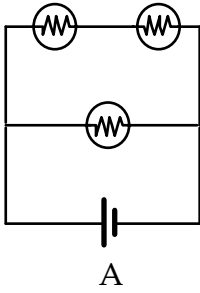
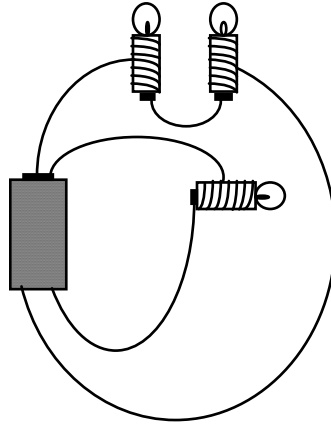

- 14) How does the resistance between the endpoints change when the switch is closed?

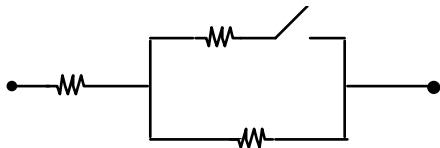

- 15) What happens to the potential difference between points 1 and 2 if bulb A is removed?

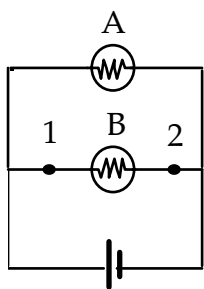

- 16) Compare the brightness of bulb A in circuit 1 with bulb A in circuit 2. Which bulb is dimmer?

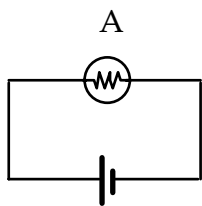

Circuit 1

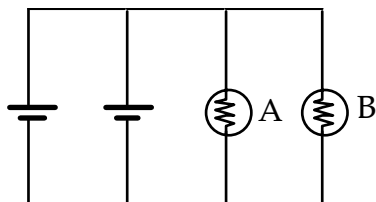

Circuit 2

- 17) Rank the currents at points 1, 2, 3, 4, 5, and 6 from highest to lowest.

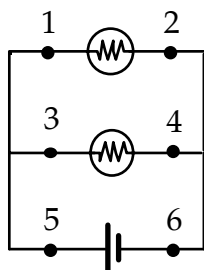

18) Which circuit(s) will light the bulb?

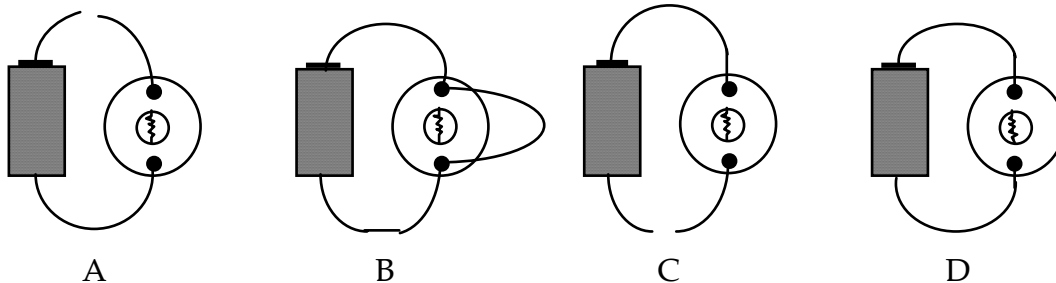

19) What happens to the brightness of bulbs A and B when a wire is connected between points 1 and 2?

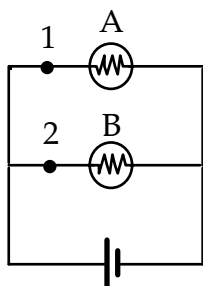

20) Is the electric field zero or non-zero inside the tungsten bulb filament? Explain your reasoning.

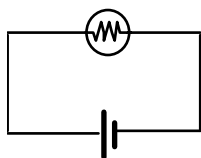

21) Which of the five circuit elements are gaining energy and which are losing energy?

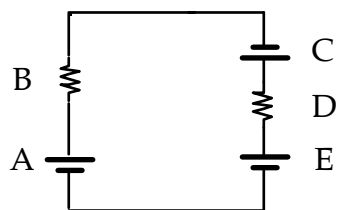

22) Compare the energy delivered per second to the light bulb in circuit 1 with the energy delivered per second to the light bulbs in circuit 2. Which bulb has the least energy delivered to it?

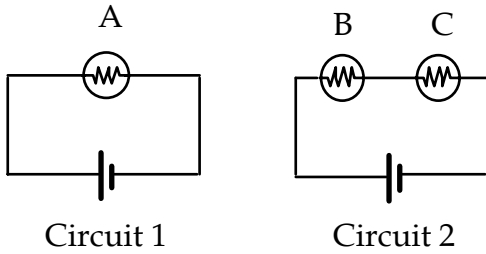

23) Which realistic circuit(s) best represent(s) the schematic diagram shown below?

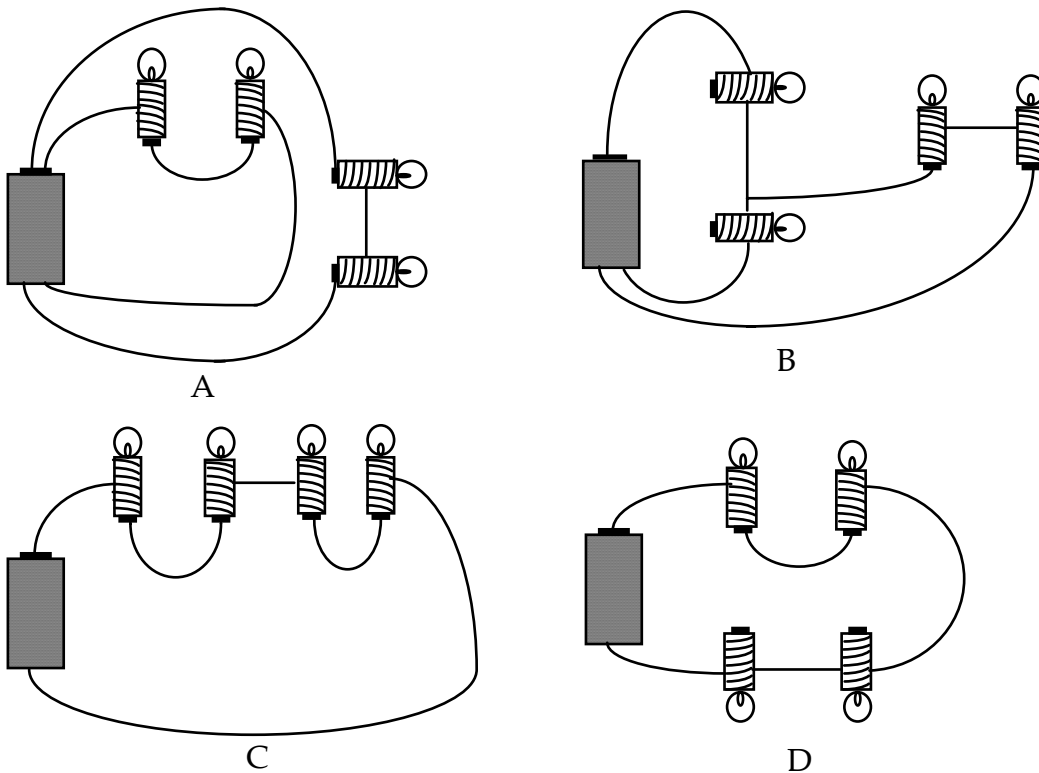
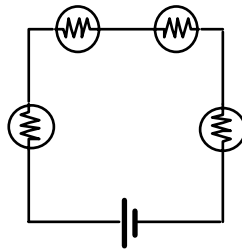

- 24) When the switch is opened, what happens to the resistance of the bulb?

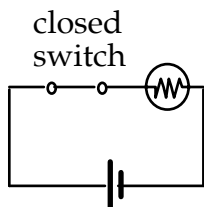

- 25) If you double the current through the battery, is the potential difference across the battery doubled? Explain your reasoning.

- 26) Compare the brightness of bulb A in circuit 1 with bulb A in circuit 2. Which bulb is brighter?

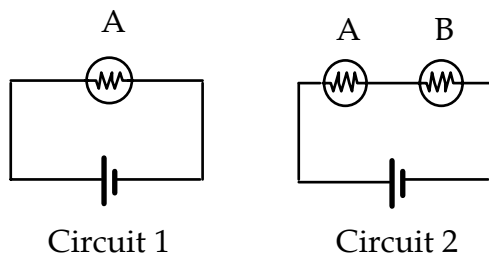

- 27) If you increase the resistance C, what happens to the brightness of bulbs A and B?

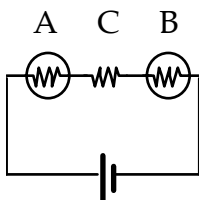

28) Will all the bulbs be the same brightness? Explain why or why not.

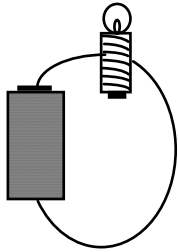

A

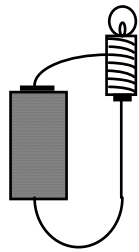

B

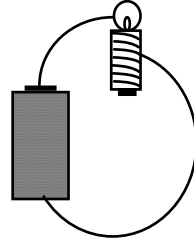

C

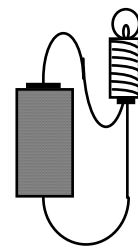

D

29) What is the potential difference between points A and B?

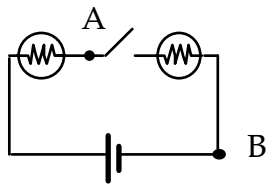

30) What happens to the brightness of bulbs A and B when the switch is closed?

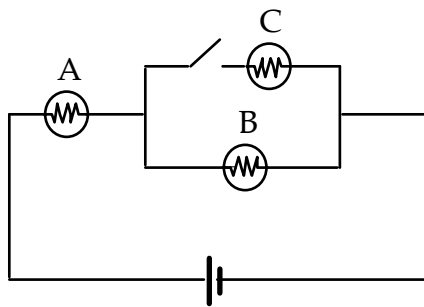

Appendix D
DIRECT version 1.0

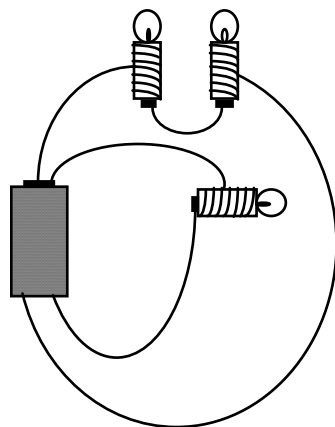

Determining and Interpreting Resistive Electric Circuits Concepts Test

Version 1.0

Instructions

Wait until you are told to begin, then turn to the next page and begin working. Answer each question as accurately as you can. There is only one correct answer for each item. Feel free to use a calculator and scratch paper if you wish.

Use a #2 pencil to record your answers on the computer sheet, but please **do not write in the test booklet**.

You will have approximately one hour to complete the test. If you finish early, check your work before handing in both the answer sheet and the test booklet.

Additional comments about the test

All light bulbs, resistors, and batteries should be considered identical unless you are told otherwise. The battery is to be assumed ideal, that is to say, the internal resistance of the battery is negligible. In addition, assume the wires have negligible resistance. Below is a key to the symbols used on this test. Study them carefully before you begin the test.

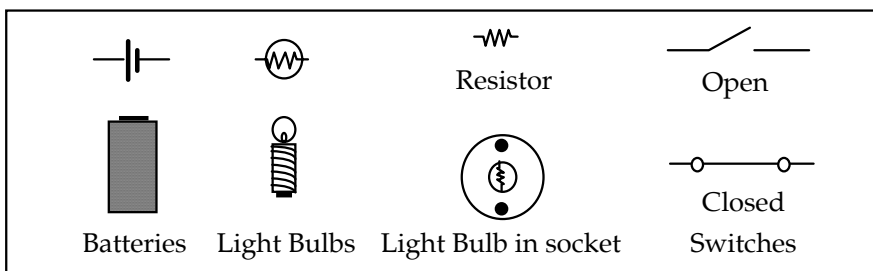

- 1) Are charges used up in a light bulb, being converted to light?
- (A) Yes, charges moving through the filament produce "friction" which heats up the filament and produces light.
- (B) Yes, charges are emitted.
- (C) No, charge is conserved. It is simply converted to another form such as heat and light.
- (D) No, charge is conserved. Charges moving through the filament produce "friction" which heats up the filament and produces light.
- 2) How does the power delivered to resistor A change when resistor B is added as shown in circuits 1 and 2 respectively?

- (A) Increases
 (B) Decreases
 (C) Stays the same

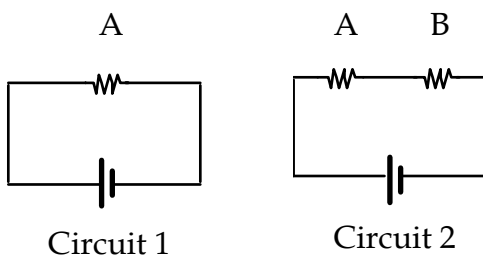

- 3) Consider the circuits shown below. Which circuit or circuits have the greatest energy delivered to it per second?

- (A) Circuit 1
 (B) Circuit 2
 (C) Circuit 3
 (D) Circuit 1 = Circuit 2
 (E) Circuit 2 = Circuit 3

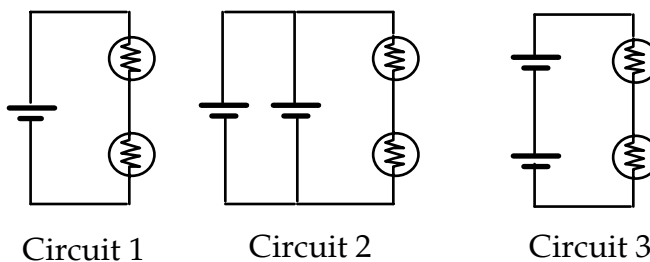

4) Consider the following circuits.

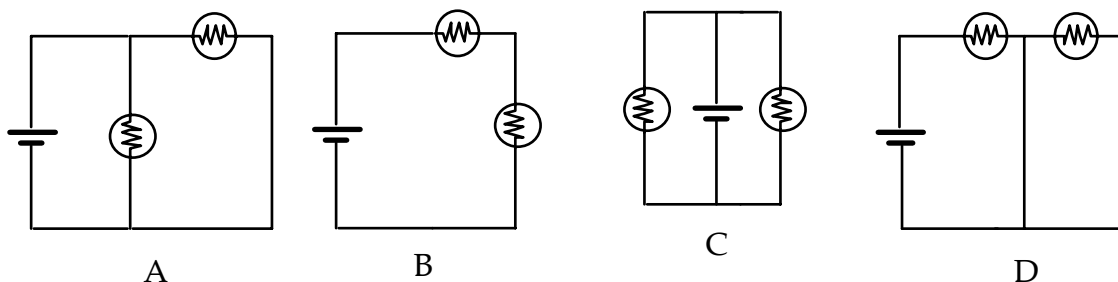

Which circuit(s) above represent(s) a circuit consisting of two light bulbs in parallel with a battery?

- (A) A
 (B) B
 (C) C
 (D) A and C
 (E) A, C, and D
- 5) Compare the resistance of branch 1 with that of branch 2. A branch is a section of a circuit. Which has the least resistance?

- (A) Branch 1
 (B) Branch 2
 (C) Neither, they are the same

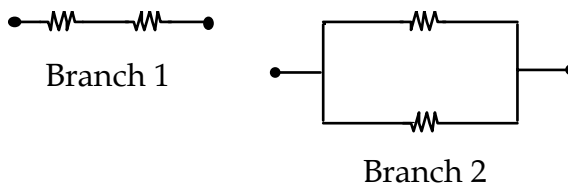

6) Rank the potential difference between points 1 and 2, points 3 and 4, and points 4 and 5 in the circuit shown below from highest to lowest.

- (A) 1 and 2; 3 and 4; 4 and 5
 (B) 1 and 2; 4 and 5; 3 and 4
 (C) 3 and 4; 4 and 5; 1 and 2
 (D) 3 and 4 = 4 and 5; 1 and 2
 (E) 1 and 2; 3 and 4 = 4 and 5

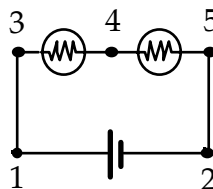

7) Compare the brightness of the bulb in circuit 1 with that in circuit 2. Which bulb is brighter?

- (A) Bulb in circuit 1
 (B) Bulb in circuit 2
 (C) Neither, they are the same

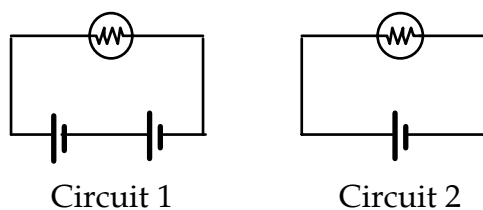

8) Compare the current at point 1 with the current at point 2. Which point has the larger current?

- (A) Point 1
- (B) Point 2
- (C) Neither, they are the same

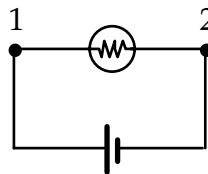

9) Which circuit(s) will light the bulb?

- (A) A
- (B) C
- (C) D
- (D) A and C
- (E) B and D

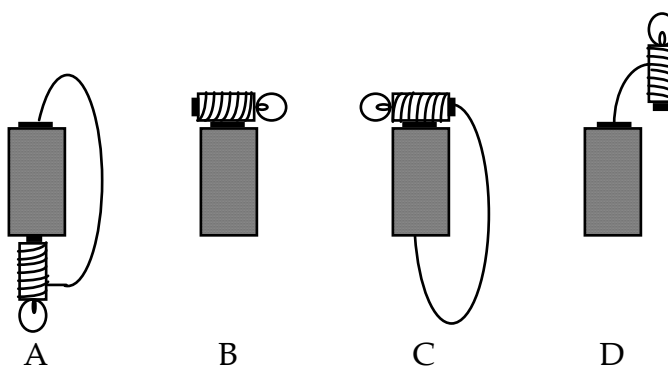

10) Compare the brightness of bulbs A and B in circuit 1 with the brightness of bulb C in circuit 2. Which bulb or bulbs are the brightest?

- (A) A
- (B) B
- (C) C
- (D) A = B
- (E) A = C

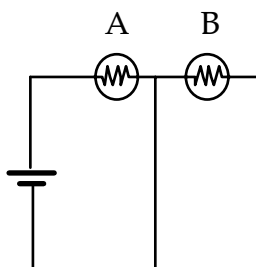

Circuit 1

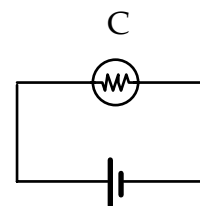

Circuit 2

11) Why do the lights in your home come on almost instantaneously?

- (A) Charges are already in the wire. When the circuit is completed, there is a rapid rearrangement of surface charges in the circuit.
- (B) Charges store energy. When the circuit is completed, the energy is released.
- (C) Charges in the wire travel very fast.
- (D) The circuits in a home are wired in parallel. Thus, a current is already flowing.

12) Consider the power delivered to each of the resistors shown in the circuits below. Which circuit or circuits have the least power delivered to it?

- (A) Circuit 1
- (B) Circuit 2
- (C) Circuit 3
- (D) Circuit 1 = Circuit 2
- (E) Circuit 1 = Circuit 3

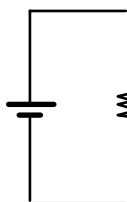

Circuit 1

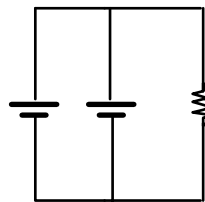

Circuit 2

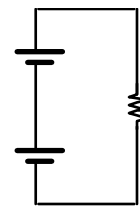

Circuit 3

13) Which schematic diagram best represents the realistic circuit shown below?

- (A) A
- (B) B
- (C) C
- (D) D
- (E) None of the above

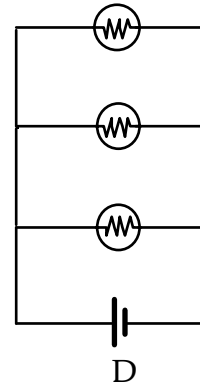
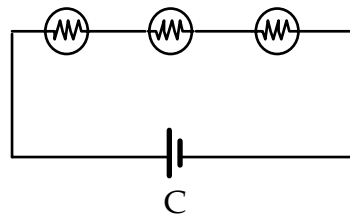
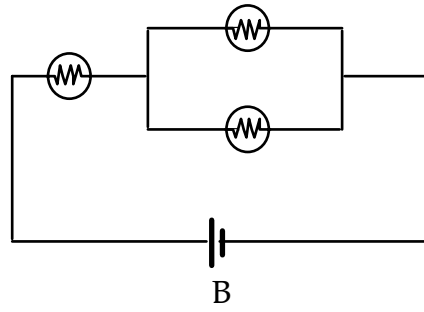
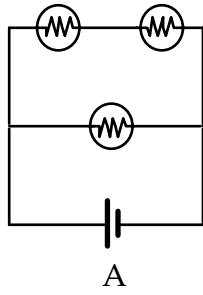
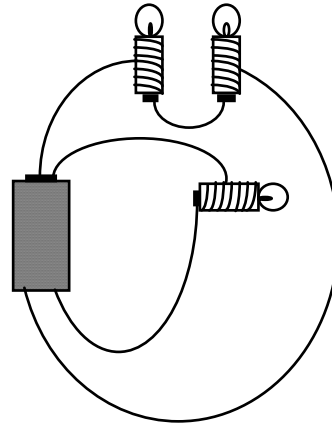

14) How does the resistance between the endpoints change when the switch is closed?

- (A) Increases
- (B) Decreases
- (C) Stays the same

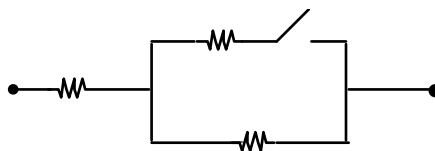

15) What happens to the potential difference between points 1 and 2 if bulb A is removed?

- (A) Increases
- (B) Decreases
- (C) Stays the same

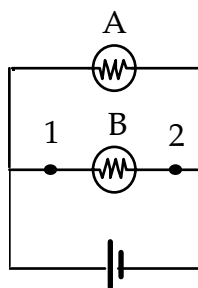

16) Compare the brightness of bulb A in circuit 1 with bulb A in circuit 2. Which bulb is dimmer?

- (A) Bulb A in circuit 1
- (B) Bulb A in circuit 2
- (C) Neither, they are the same

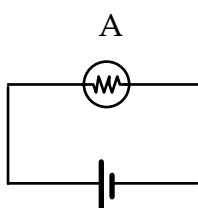

Circuit 1

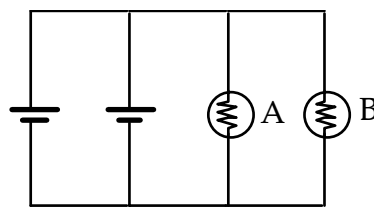

Circuit 2

17) Rank the currents at points 1, 2, 3, 4, 5, and 6 from highest to lowest.

- (A) 5, 1, 3, 2, 4, 6
- (B) 5, 3, 1, 4, 2, 6
- (C) 5=6, 3=4, 1=2
- (D) 5=6, 1=2=3=4
- (E) 1=2=3=4=5=6

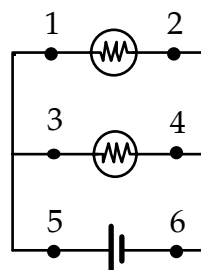

18) Which circuit(s) will light the bulb?

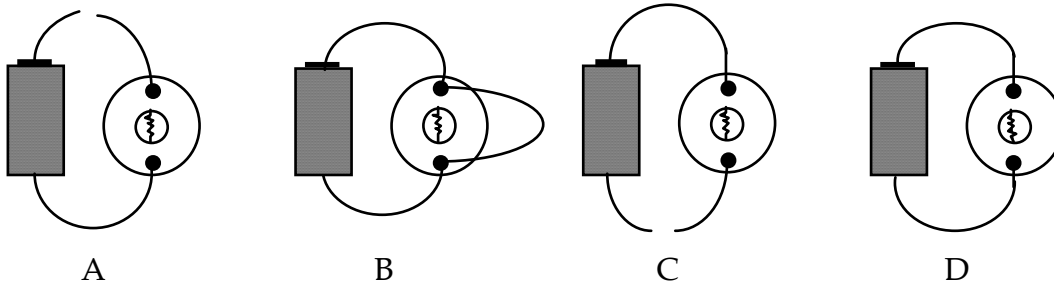

- (A) A
- (B) B
- (C) D
- (D) B and D
- (E) A and C

19) What happens to the brightness of bulbs A and B when a wire is connected between points 1 and 2?

- (A) Increases
- (B) Decreases
- (C) Stays the same
- (D) A becomes brighter than B
- (E) Neither bulb will light

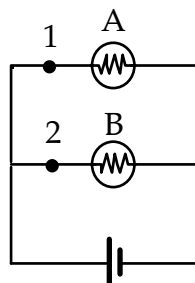

20) Is the electric field zero or non-zero inside the tungsten bulb filament?

- (A) Zero because the filament is a conductor.
- (B) Zero because there is a current flowing.
- (C) Non-zero because the circuit is complete and a current is flowing.
- (D) Non-zero because there are charges on the surface of the filament.

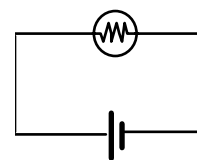

21) Compare the energy delivered per second to the light bulb in circuit 1 with the energy delivered per second to the light bulbs in circuit 2. Which bulb or bulbs have the least energy delivered to it per second?

- (A) A
- (B) B
- (C) C
- (D) B = C
- (E) A = B = C

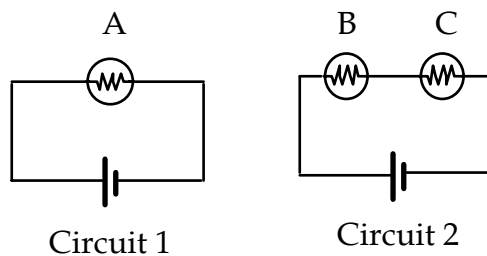

22) Which realistic circuit(s) represent(s) the schematic diagram shown below?

- (A) B
- (B) C
- (C) D
- (D) A and B
- (E) C and D

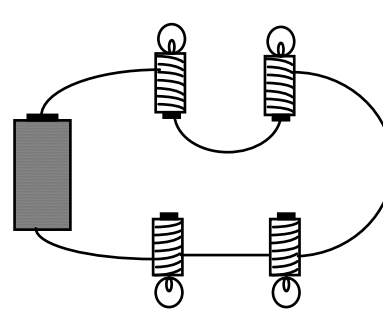
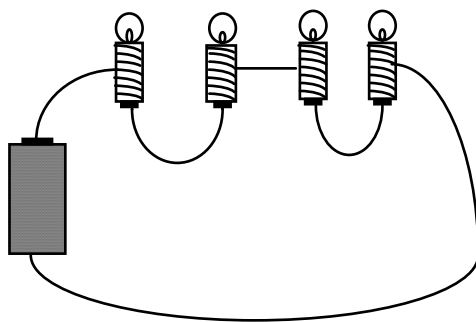
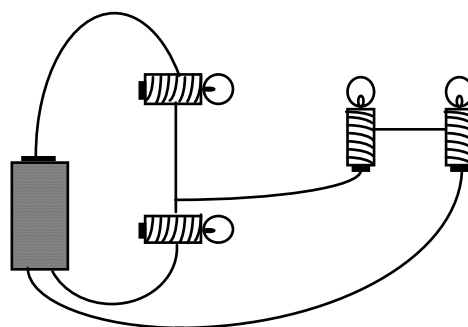
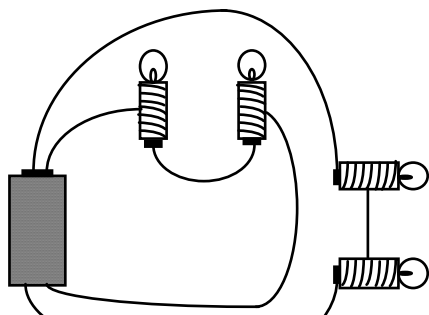
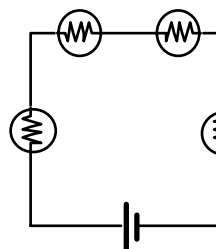

23) Immediately after the switch is opened, what happens to the resistance of the bulb?

- (A) The resistance increases.
- (B) The resistance decreases.
- (C) The resistance stays the same.
- (D) The resistance goes to zero.

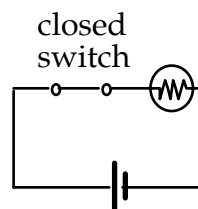

24) If you double the current through a battery, is the potential difference across a battery doubled?

- (A) Yes, because Ohm's law says $V = IR$.
- (B) Yes, because as you increase the resistance, you increase the potential difference.
- (C) No, because as you double the current, you reduce the potential difference by half.
- (D) No, because the potential difference is a property of the battery.
- (E) No, because the potential difference is a property of everything in the circuit.

25) Compare the brightness of bulb A in circuit 1 with bulb A in circuit 2. Which bulb is brighter?

- (A) Bulb A in circuit 1
- (B) Bulb A in circuit 2
- (C) Neither, they are the same

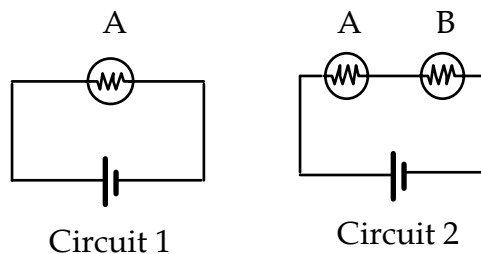

26) If you increase the resistance C, what happens to the brightness of bulbs A and B?

- (A) A stays the same, B dims
- (B) A dims, B stays the same
- (C) A and B increase
- (D) A and B decrease
- (E) A and B remain the same

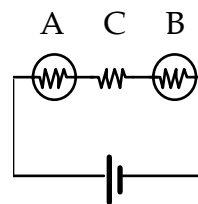

27) Will all the bulbs be the same brightness?

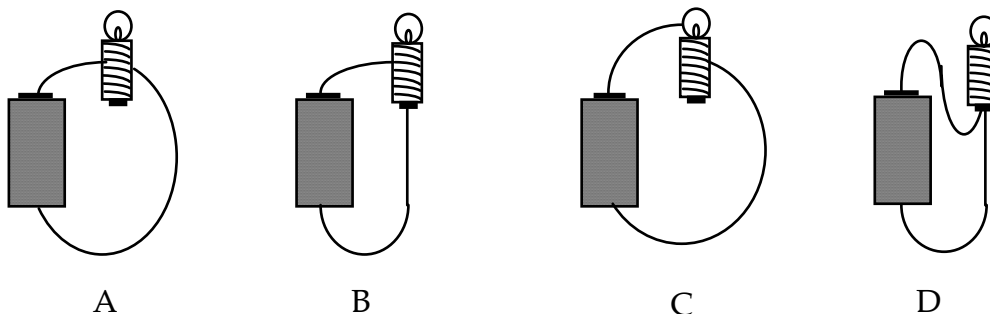

- (A) Yes, because they all have the same type of circuit wiring.
 (B) No, because only B will light. The connections to A, C, and D are not correct.
 (C) No, because only D will light. D is the only complete circuit.
 (D) No, C will not light but A, B, and D will.

28) What is the potential difference between points A and B?

- (A) 0 V
 (B) 3 V
 (C) 6 V
 (D) 12 V

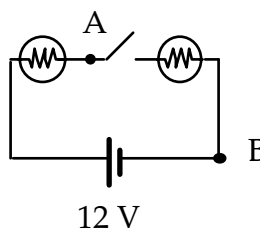

29) What happens to the brightness of bulbs A and B when the switch is closed?

- (A) A stays the same, B dims
 (B) A brighter, B dims
 (C) A and B increase
 (D) A and B decrease
 (E) A and B remain the same

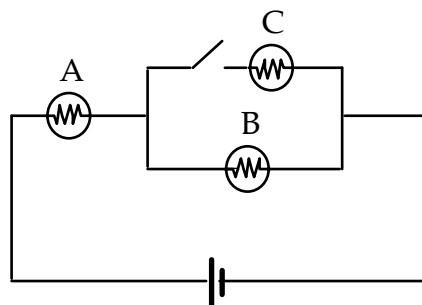

Appendix E
DIRECT version 1.1

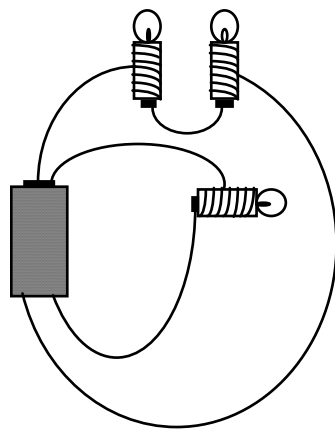

Determining and Interpreting Resistive Electric Circuits Concepts Test

Version 1.1

Instructions

Wait until you are told to begin, then turn to the next page and begin working. Answer each question as accurately as you can. There is only one correct answer for each item. Feel free to use a calculator and scratch paper if you wish.

Use a #2 pencil to **record your answers** on the Opscan sheet, but please **do not write in the test booklet**.

You will have approximately 30 minutes to complete the test. If you finish early, check your work before handing in both the answer sheet and the test booklet.

Additional comments about the test

All light bulbs, resistors, and batteries are identical unless you are told otherwise. The battery is ideal, that is to say, the internal resistance of the battery is negligible. In addition, the wires have negligible resistance. Below is a key to the symbols used on this test. Study them carefully before you begin the test.

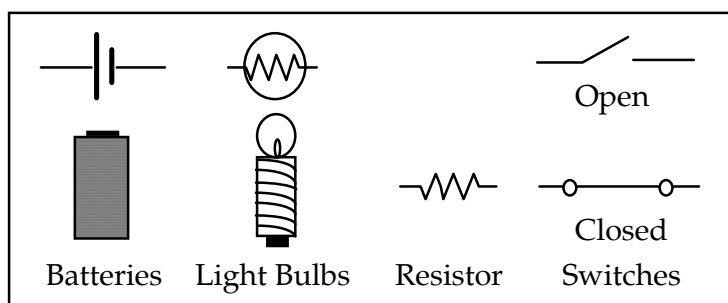

- 1) Are charges used up in the production of light in a light bulb?
- (A) Yes, charge is used up. Charges moving through the filament produce "friction" which heats up the filament and produces light.
- (B) Yes, charge is used up. Charges are emitted as photons and are lost.
- (C) Yes, charge is used up. Charges are absorbed by the filament and are lost.
- (D) No, charge is conserved. Charges are simply converted to another form such as heat and light.
- (E) No, charge is conserved. Charges moving through the filament produce "friction" which heats up the filament and produces light.
- 2) How does the power delivered to resistor A change when resistor B is added to the circuit? The power delivered to resistor A _____.

- (A) Quadruples (4 times)
 (B) Doubles
 (C) Stays the same
 (D) Reduces by half
 (E) Reduces by one quarter (1/4)

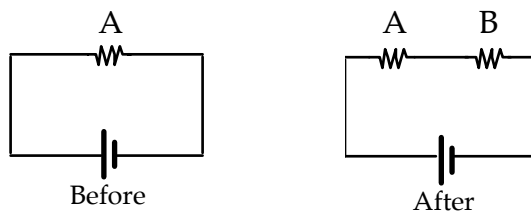

- 3) Which circuit or circuits have the GREATEST energy delivered to them per second?

- (A) Circuit 1
 (B) Circuit 2
 (C) Circuit 3
 (D) Circuit 1 = Circuit 2
 (E) Circuit 2 = Circuit 3

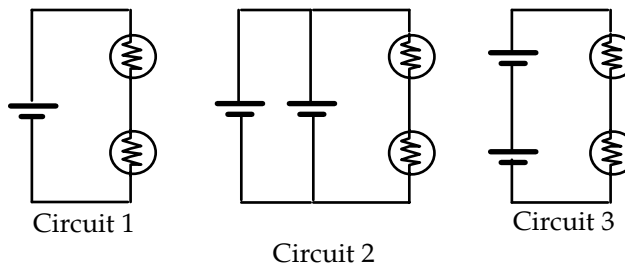

- 4) Which circuit or circuits below represent a circuit consisting of two light bulbs in parallel with a battery?

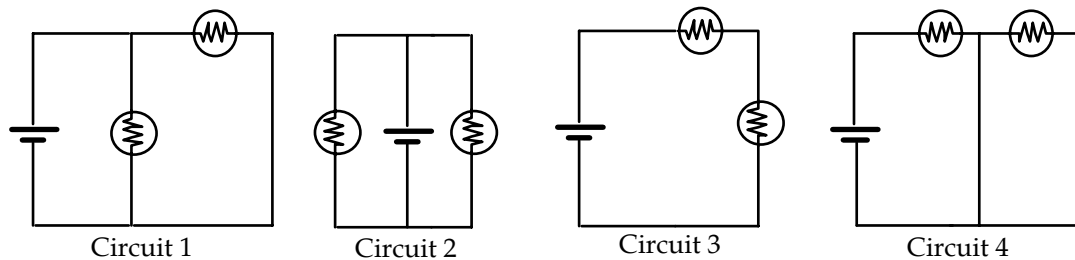

- (A) Circuit 1
 (B) Circuit 2
 (C) Circuit 3
 (D) Circuits 1 and 2
 (E) Circuits 1, 2, and 4
- 5) Compare the resistance of branch 1 with that of branch 2. A branch is a section of a circuit. The resistance of branch 1 is _____ branch 2.

- (A) Four times
 (B) Double
 (C) The same as
 (D) Half
 (E) One quarter ($1/4$)

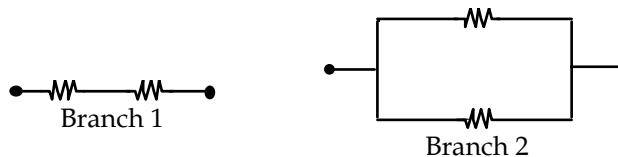

- 6) Rank the potential difference between points 1 and 2, points 3 and 4, and points 4 and 5 in the circuit shown below from HIGHEST to LOWEST.

- (A) 1 and 2; 3 and 4; 4 and 5
 (B) 1 and 2; 4 and 5; 3 and 4
 (C) 3 and 4; 4 and 5; 1 and 2
 (D) 3 and 4 = 4 and 5; 1 and 2
 (E) 1 and 2; 3 and 4 = 4 and 5

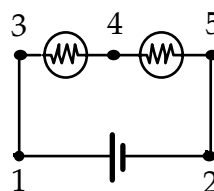

- 7) Compare the brightness of the bulb in circuit 1 with that in circuit 2. Which bulb is BRIGHTER?

- (A) Bulb in circuit 1 because two batteries in series provide less voltage
- (B) Bulb in circuit 1 because two batteries in series provide more voltage
- (C) Bulb in circuit 2 because two batteries in parallel provide less voltage
- (D) Bulb in circuit 2 because two batteries in parallel provide more voltage
- (E) Neither, they are the same

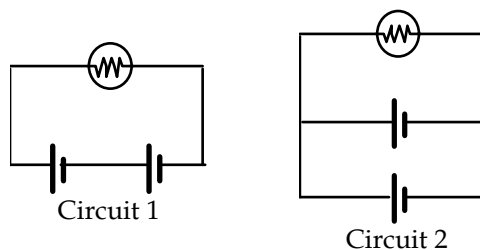

- 8) Compare the current at point 1 with the current at point 2. Which point has the LARGER current?

- (A) Point 1
- (B) Point 2
- (C) Neither, they are the same. Current travels in one direction around the circuit.
- (D) Neither, they are the same. Currents travel in two directions around the circuit.

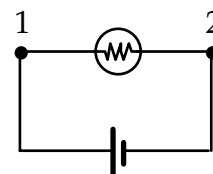

- 9) Which circuit or circuits will light the bulb?

- (A) Circuit 1
- (B) Circuit 2
- (C) Circuit 3
- (D) Circuits 1 and 3
- (E) Circuits 1, 3, and 4

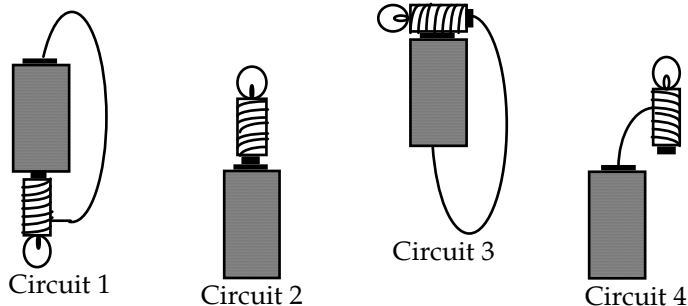

10) Compare the brightness of bulbs A, B, and C in these circuits. Which bulb or bulbs are the BRIGHTEST?

- (A) A
- (B) B
- (C) C
- (D) A = B
- (E) A = C

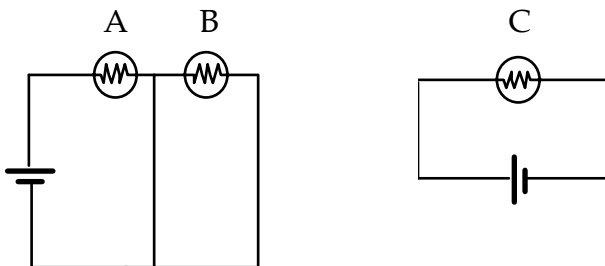

11) Why do the lights in your home come on almost instantaneously when you turn on the switch?

- (A) When the circuit is completed, there is a rapid rearrangement of surface charges in the circuit.
- (B) Charges store energy. When the circuit is completed, the energy is released.
- (C) Charges in the wire travel very fast.
- (D) The circuits in a home are wired in parallel. Thus, a current is already flowing.
- (E) Charges in the wire are like marbles in a tube. When the circuit is completed, the charges push each other through the wire.

12) Consider the power delivered to each of the resistors shown in the circuits below. Which circuit or circuits have the LEAST power delivered to them?

- (A) Circuit 1
- (B) Circuit 2
- (C) Circuit 3
- (D) Circuit 1 = Circuit 2
- (E) Circuit 1 = Circuit 3

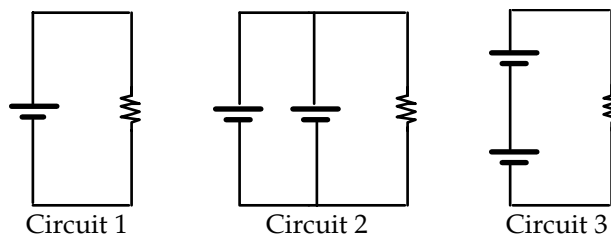

13) Which schematic diagram best represents the realistic circuit shown below?

- (A) Circuit 1
- (B) Circuit 2
- (C) Circuit 3
- (D) Circuit 4
- (E) None of the above

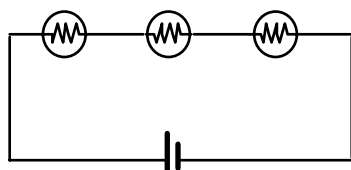
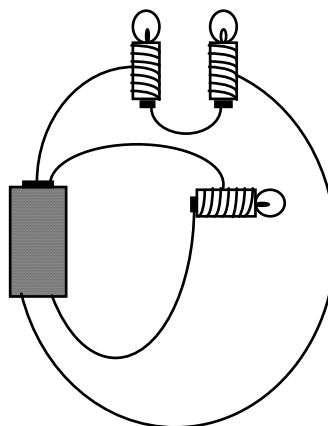

Circuit 1

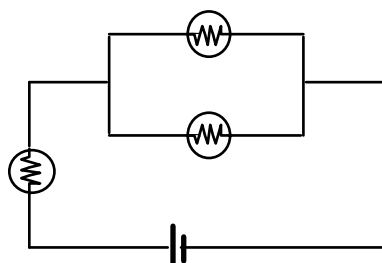

Circuit 2

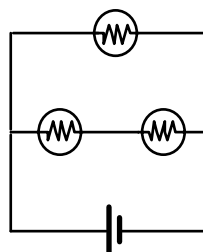

Circuit 3

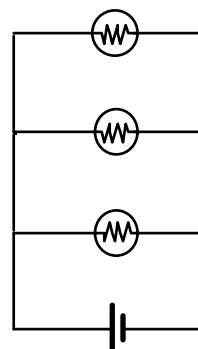

Circuit 4

14) How does the resistance between the endpoints change when the switch is closed?

- (A) Increases by R
- (B) Increases by $R/2$
- (C) Stays the same
- (D) Decreases by $R/2$
- (E) Decreases by R

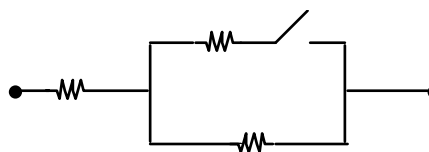

15) What happens to the potential difference between points 1 and 2 when the switch is closed?

- (A) Quadruples (4 times)
- (B) Doubles
- (C) Stays the same
- (D) Reduces by half
- (E) Reduces by one quarter ($1/4$)

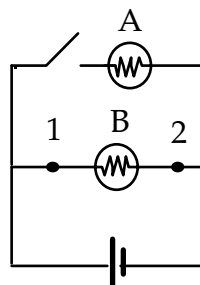

16) Compare the brightness of bulb A with bulb B. Bulb A is _____ bright as Bulb B.

- (A) Four times as
- (B) Twice as
- (C) Equally
- (D) Half as
- (E) One fourth ($1/4$) as

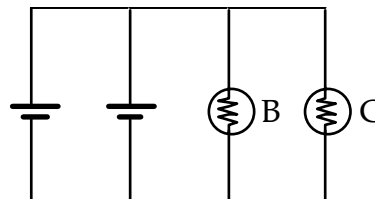
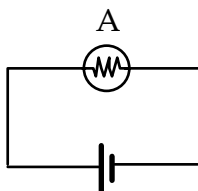

17) Rank the currents at points 1, 2, 3, 4, 5, and 6 from HIGHEST to LOWEST.

- (A) 5, 3, 1, 2, 4, 6
- (B) 5, 3, 1, 4, 2, 6
- (C) $5=6$, $3=4$, $1=2$
- (D) $5=6$, $1=2=3=4$
- (E) $1=2=3=4=5=6$

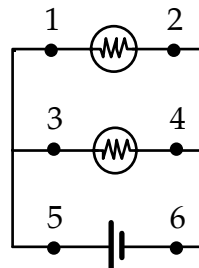

18) Which circuit(s) will light the bulb?

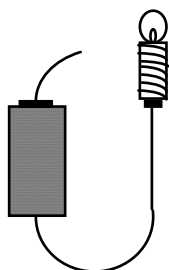

Circuit 1

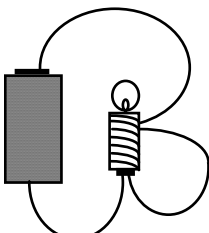

Circuit 2

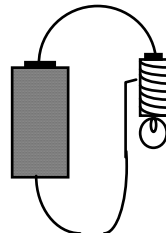

Circuit 3

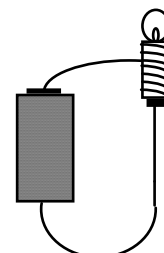

Circuit 4

- (A) Circuit 1
- (B) Circuit 2
- (C) Circuit 4
- (D) Circuits 2 and 4
- (E) Circuits 1 and 3

19) What happens to the brightness of bulbs A and B when a wire is connected between points 1 and 2?

- (A) Both increase
- (B) Both decrease
- (C) They stay the same
- (D) A becomes brighter than B
- (E) Neither bulb will light

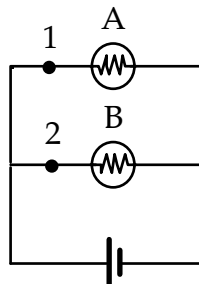

20) Is the electric field zero or non-zero inside the bulb filament?

- (A) Zero because the filament is a conductor.
- (B) Zero because a current is flowing.
- (C) Zero because there are charges on the surface of the filament.
- (D) Non-zero because a current is flowing which produces the field.
- (E) Non-zero because there are charges on the surface of the filament which produce the field.

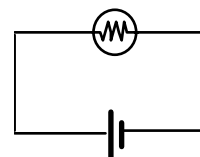

21) Compare the energy delivered per second to each light bulb shown below. Which bulb or bulbs have the LEAST energy delivered to them per second?

- (A) A
- (B) B
- (C) C
- (D) B = C
- (E) A = B = C

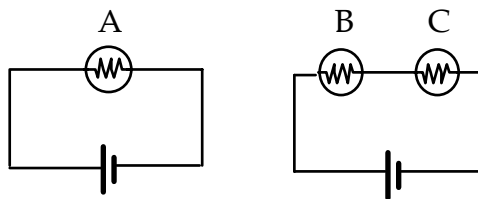

22) Which realistic circuit or circuits represent the schematic diagram shown below?

- (A) Circuit 2
- (B) Circuit 3
- (C) Circuit 4
- (D) Circuits 1 and 2
- (E) Circuits 3 and 4

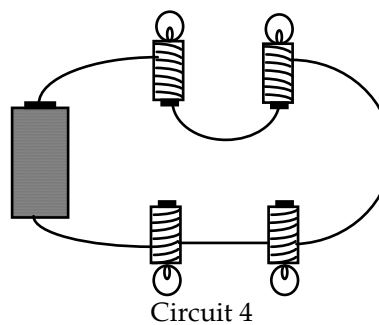
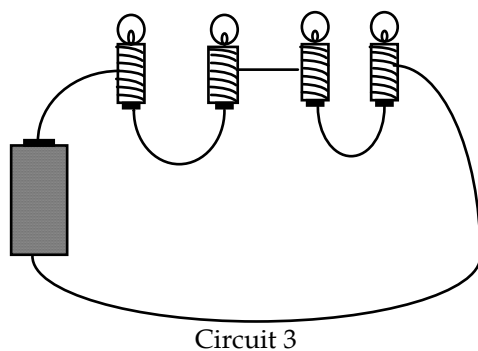
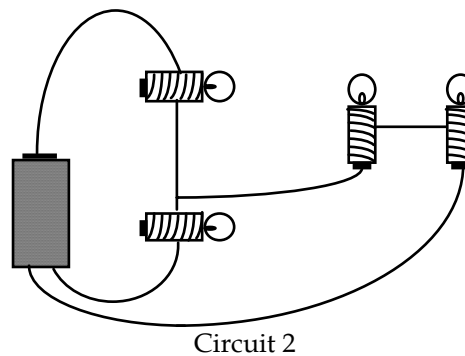
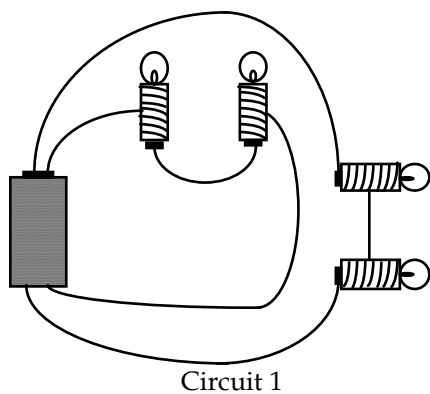
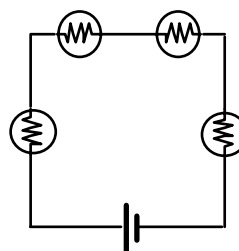

23) Immediately after the switch is opened, what happens to the resistance of the bulb?

- (A) The resistance goes to infinity.
- (B) The resistance increases.
- (C) The resistance decreases.
- (D) The resistance stays the same.
- (E) The resistance goes to zero.

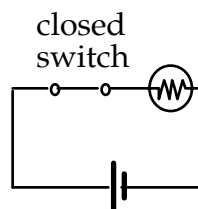

24) If you double the current through a battery, is the potential difference across a battery doubled?

- (A) Yes, because Ohm's law says $V = IR$.
- (B) Yes, because as you increase the resistance, you increase the potential difference.
- (C) No, because as you double the current, you reduce the potential difference by half.
- (D) No, because the potential difference is a property of the battery.
- (E) No, because the potential difference is a property of everything in the circuit.

25) Compare the brightness of bulb A with bulb B. Bulb A is _____ bright as bulb B.

- (A) Four times as
- (B) Twice as
- (C) Equally
- (D) Half as
- (E) One fourth ($1/4$) as

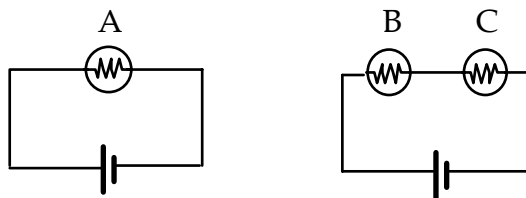

26) If you increase the resistance C, what happens to the brightness of bulbs A and B?

- (A) A stays the same, B dims
- (B) A dims, B stays the same
- (C) A and B increase
- (D) A and B decrease
- (E) A and B remain the same

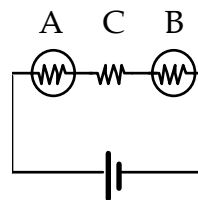

27) Will all the bulbs be the same brightness?

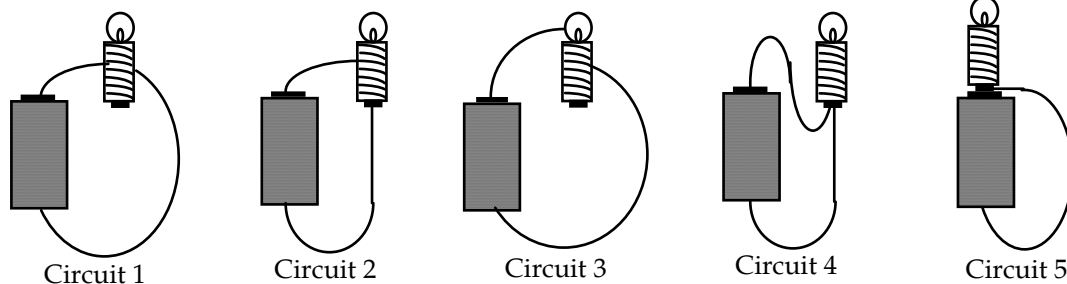

- (A) Yes, because they all have the same type of circuit wiring.
 (B) No, because only Circuit 2 will light.
 (C) No, because only Circuits 4 and 5 will light.
 (D) No, because only Circuits 1 and 4 will light.
 (E) No, Circuit 3 will not light but Circuits 1, 2, 4, and 5 will.

28) What is the potential difference between points A and B?

- (A) 0 V
 (B) 3 V
 (C) 6 V
 (D) 12 V
 (E) None of the above

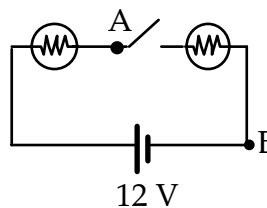

29) What happens to the brightness of bulbs A and B when the switch is closed?

- (A) A stays the same, B dims
 (B) A brighter, B dims
 (C) A and B increase
 (D) A and B decrease
 (E) A and B remain the same

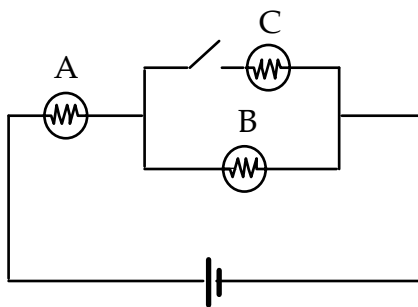

Appendix F
Instructions for the 1996 Independent Panel of Experts

Hello,

I am trying to assess the content validity of the DIRECT. I am asking several faculty members and graduate students to participate in this process. Below is a description of what would be involved. You should not feel obligated to participate.

For those of you who may be unaware of my work, DIRECT stands for Determining and Interpreting Resistive Electric Circuits Concepts Test. DIRECT is a 29 item multiple choice exam covering resistive direct current electric circuits. It has been designed for use as a post-instruction instrument and is appropriate for students in both high school and college/university physics. DIRECT will be useful for both diagnostic and research purposes.

I was wondering if you would have about 4 hours some time before the end of March to do the following:

- 1) Take the DIRECT. This should take you no more than 30 minutes.
- 2) Match objectives to individual test items. This will be the time consuming part of the process.

Enclosed is a list of 11 objectives. You will be asked to assign each test item one or two primary objectives followed by any secondary objectives you feel are appropriate. By primary, I mean, the main objective that the test item is trying to assess. Secondary objectives are ones that students may need to take into account in answering the question but are not the main thrust of the question.

For example,

How does the power delivered to resistor A change when bulb B is removed?

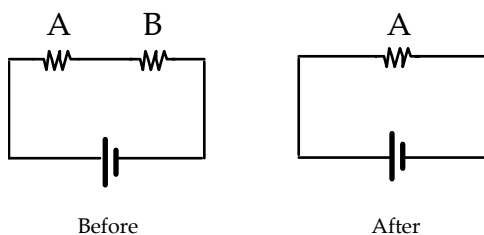

The primary objective would be power. Secondary objectives may be resistance and current. There may be others you can think of too.

- 3) Comment on the test items. This is *optional* but any comments would be appreciated.

I have enclosed a copy of the DIRECT, an Opscan sheet for you to record your answers to the test, the categorized objectives, and a sheet for you to record the matching of objectives to test items and space to comment on the test items. If you do not think you will have time, please return the materials to my mailbox in ____ as soon as possible.

If you have any questions, please do not hesitate to ask. I can be reached by e-mail at ____ or by phone at ____.

Thank you in advance for your time.

Paula V. Engelhardt
Graduate Research Assistant
NCSU

Appendix G
Graphical representation of the results
from DIRECT versions 1.0 and 1.1

Note that the letter C above the bar indicates the correct answer selection.

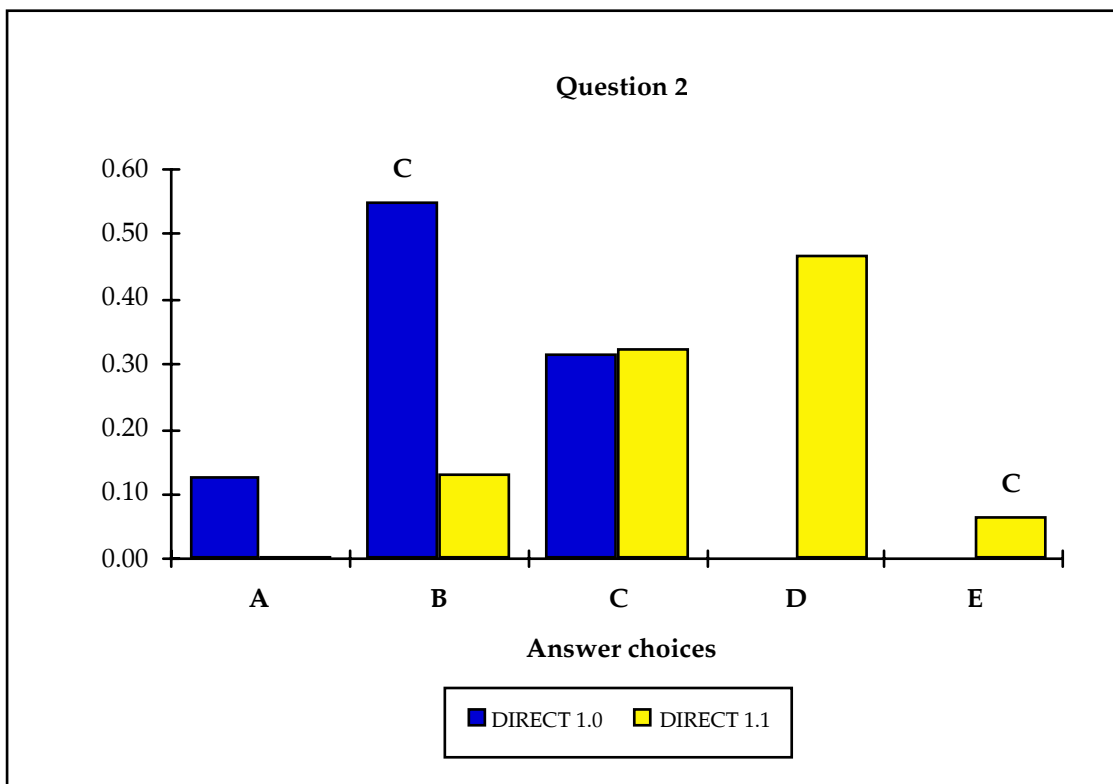
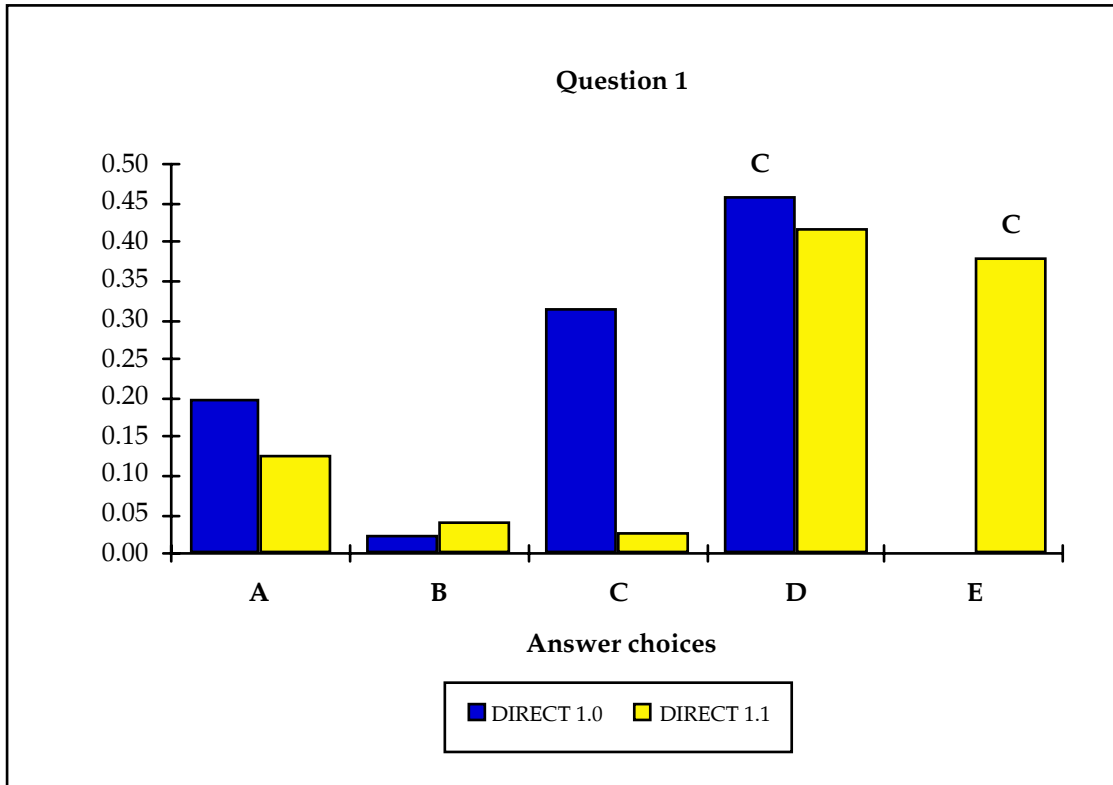

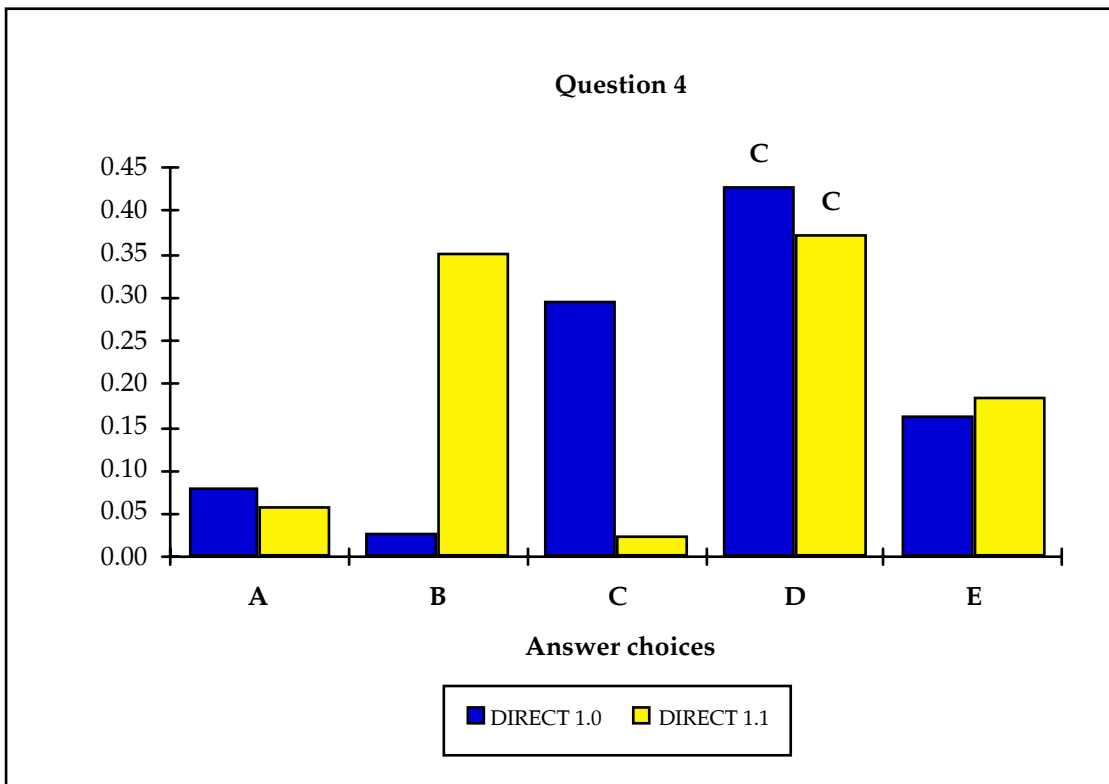
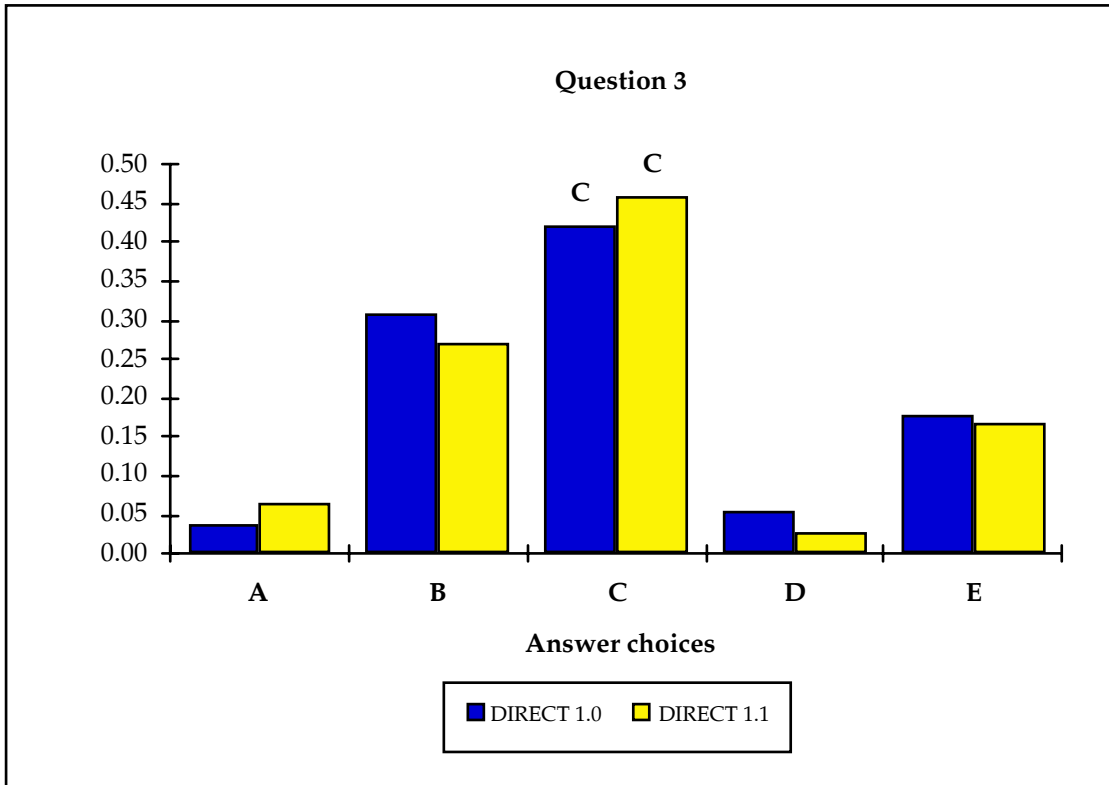

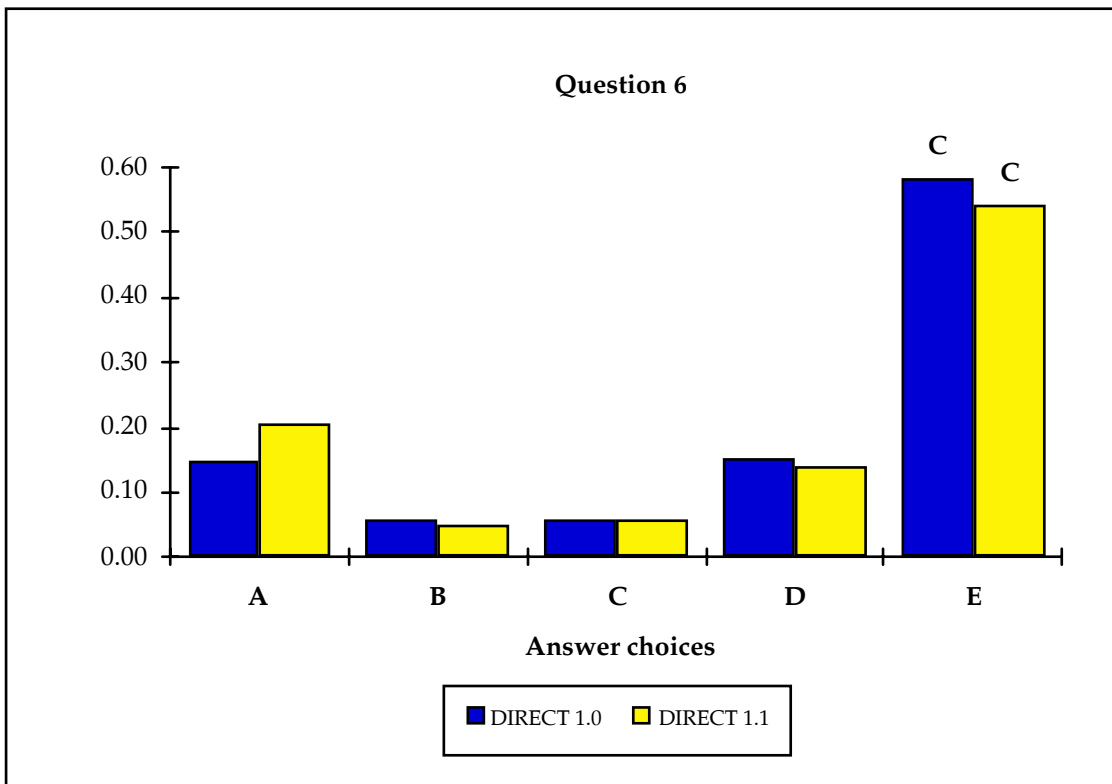
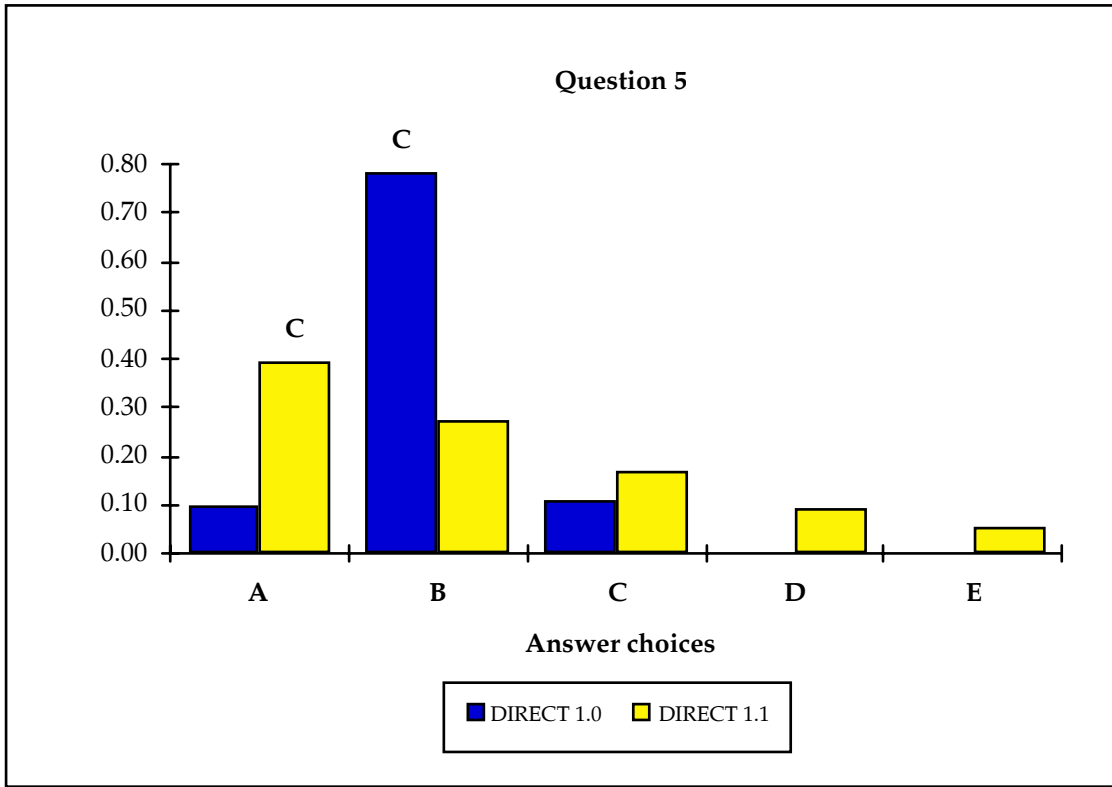

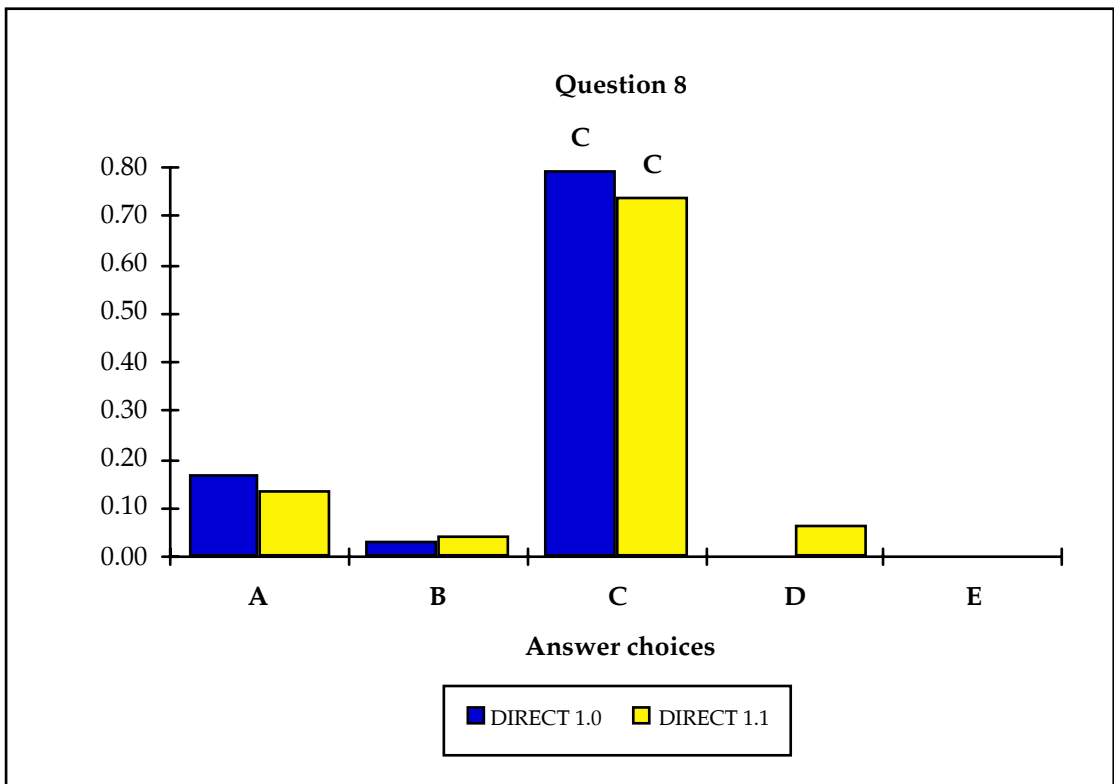
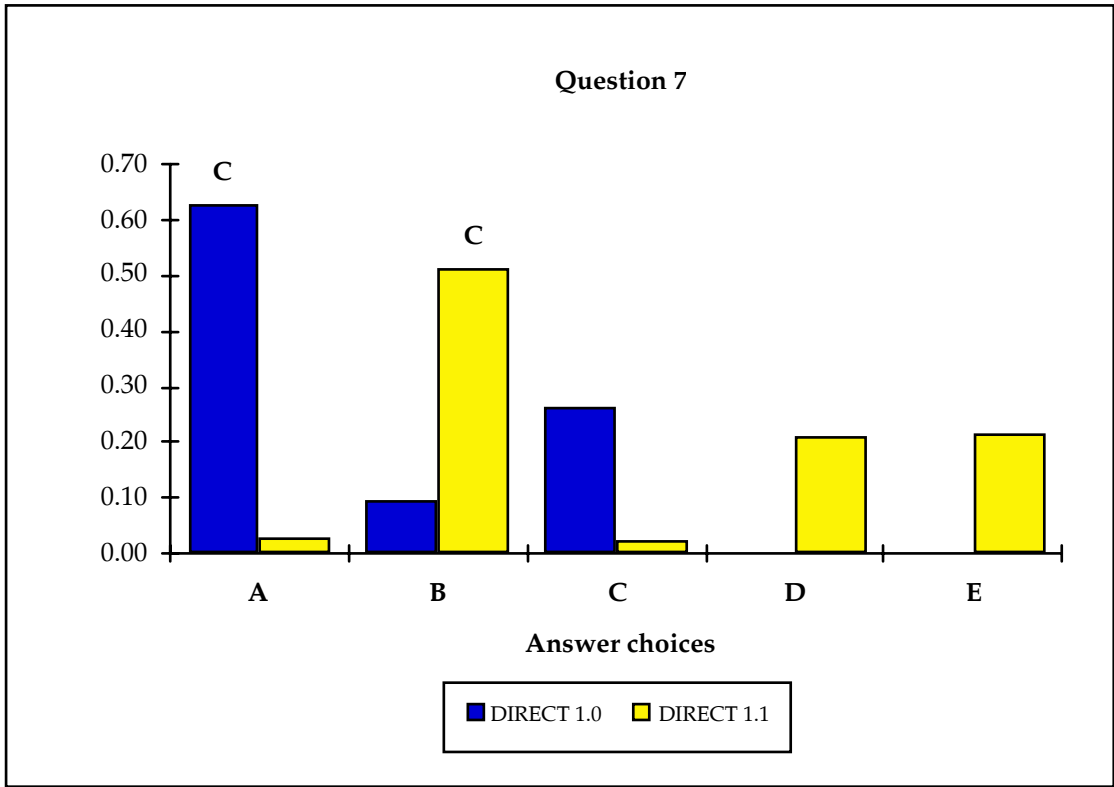

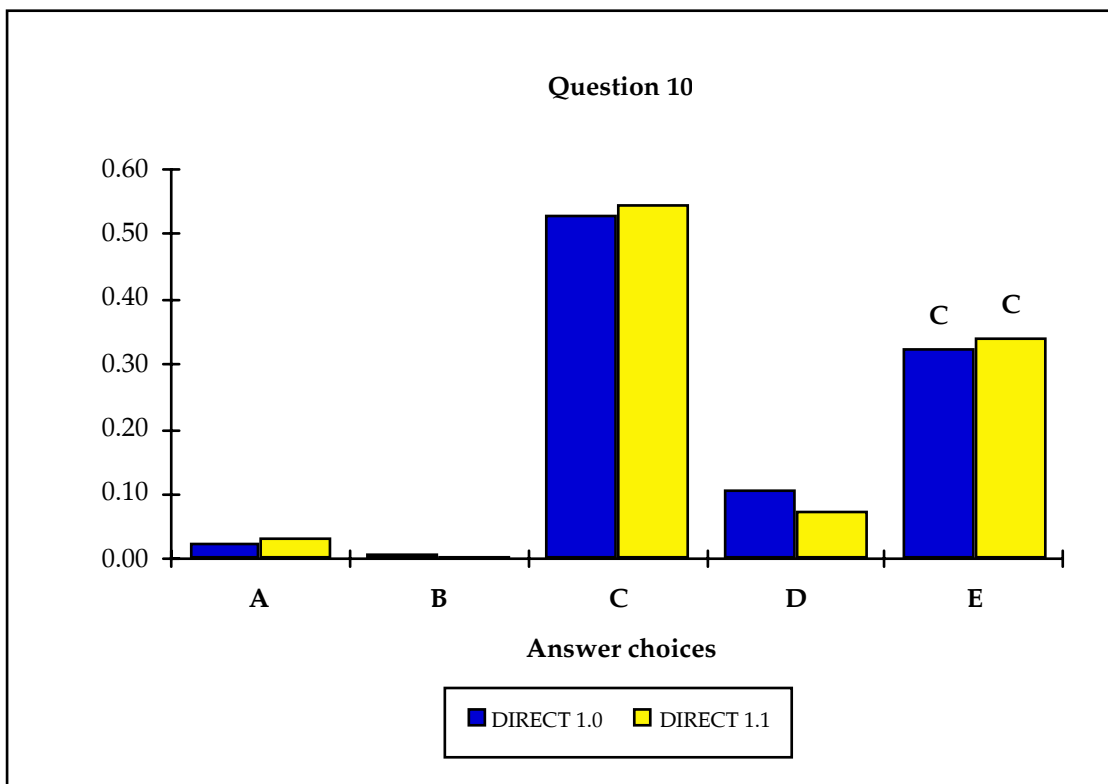
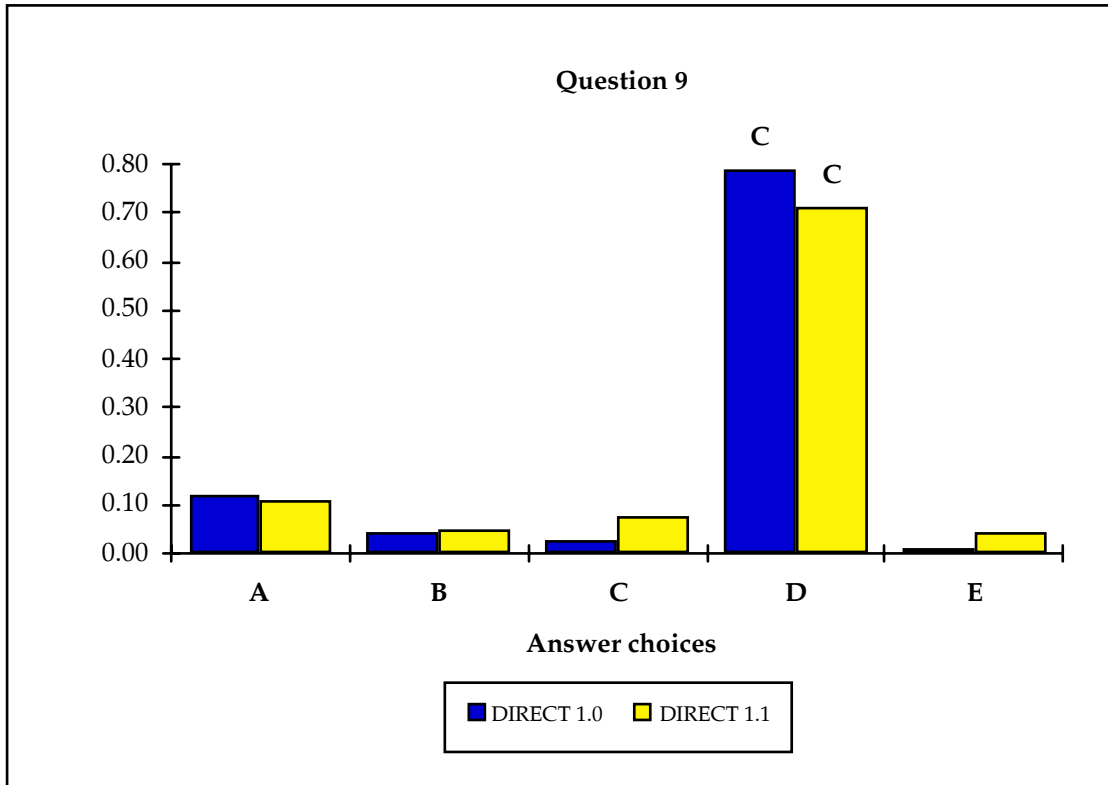

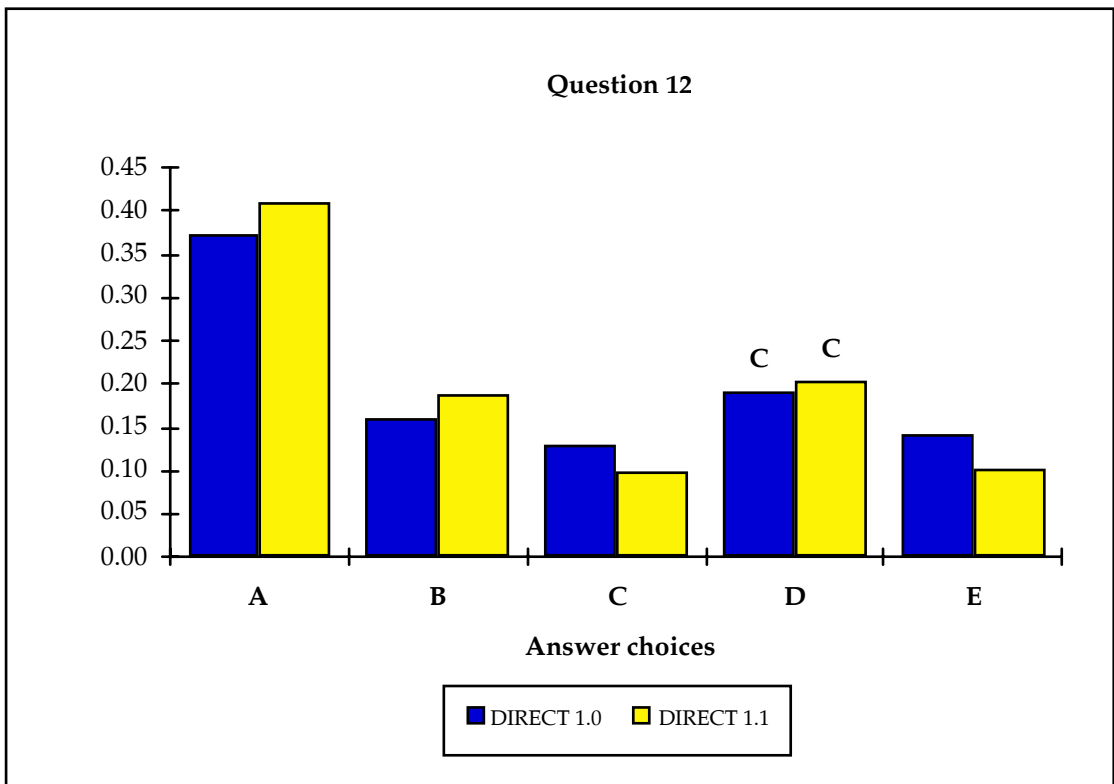
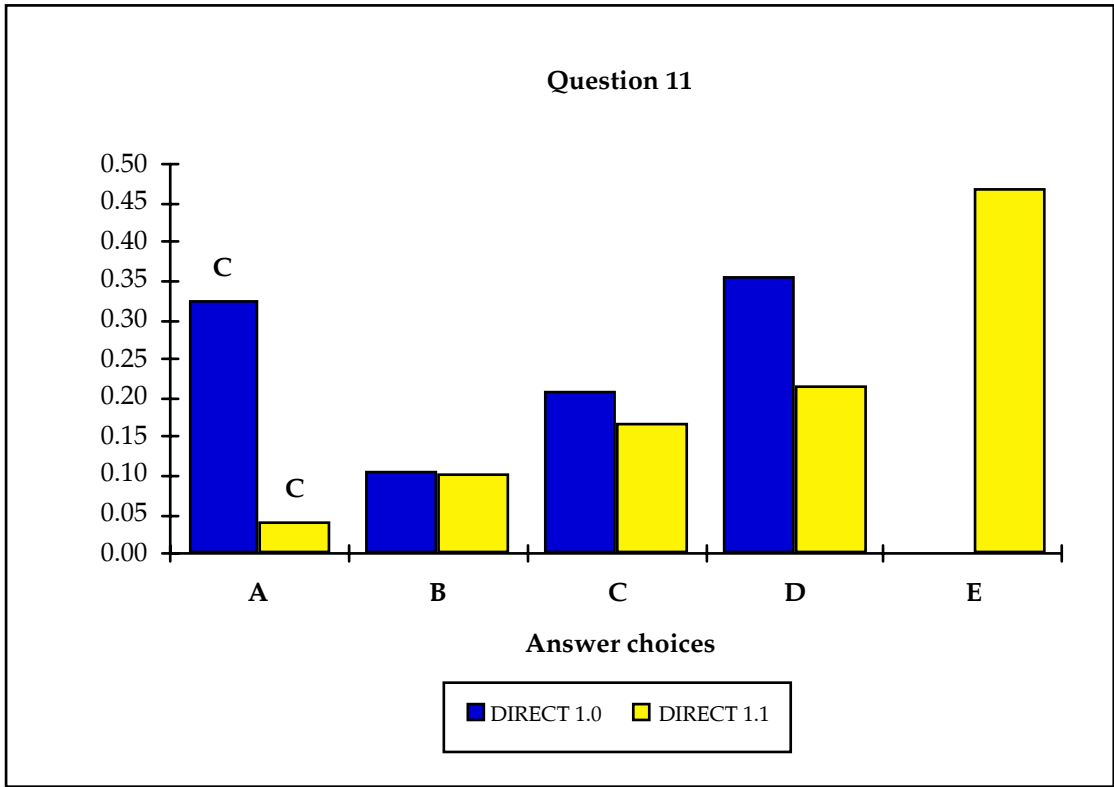

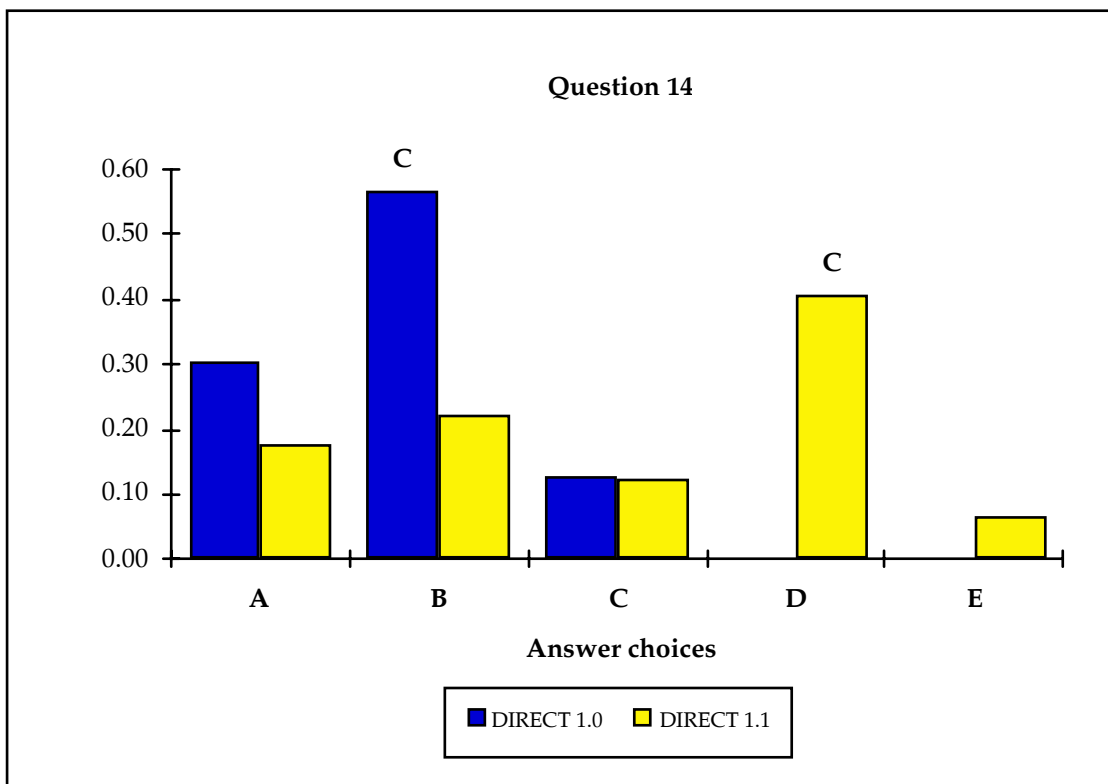
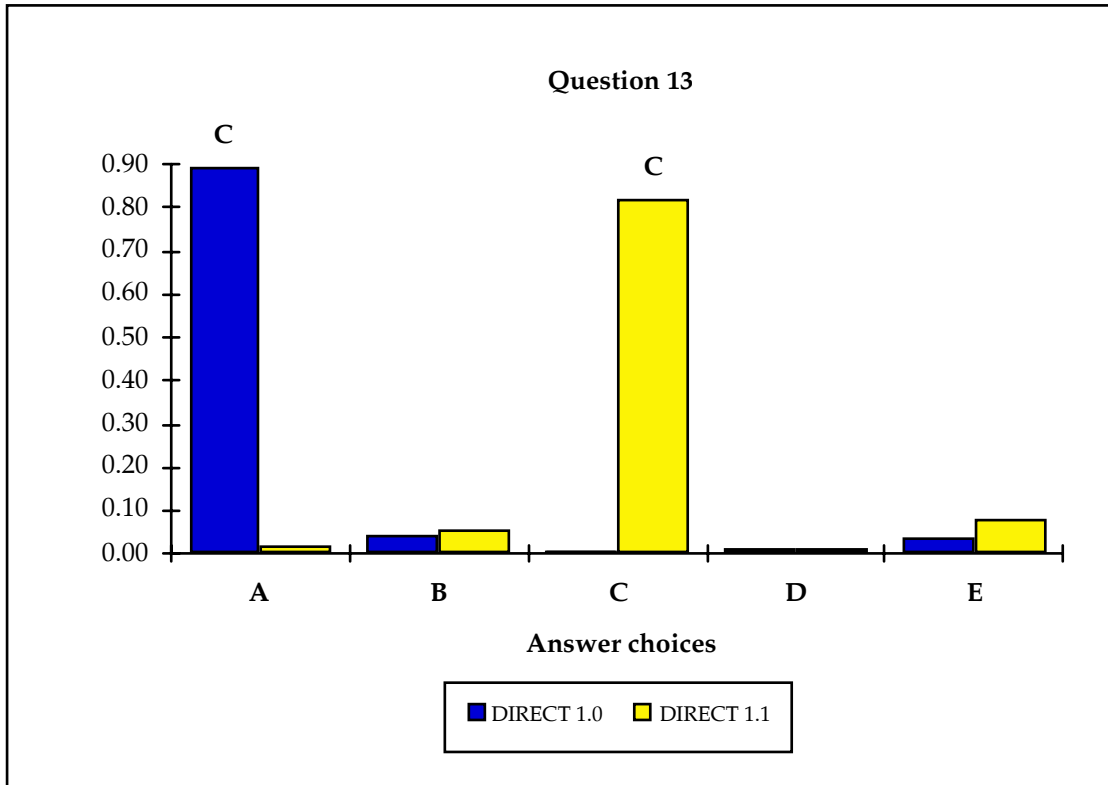

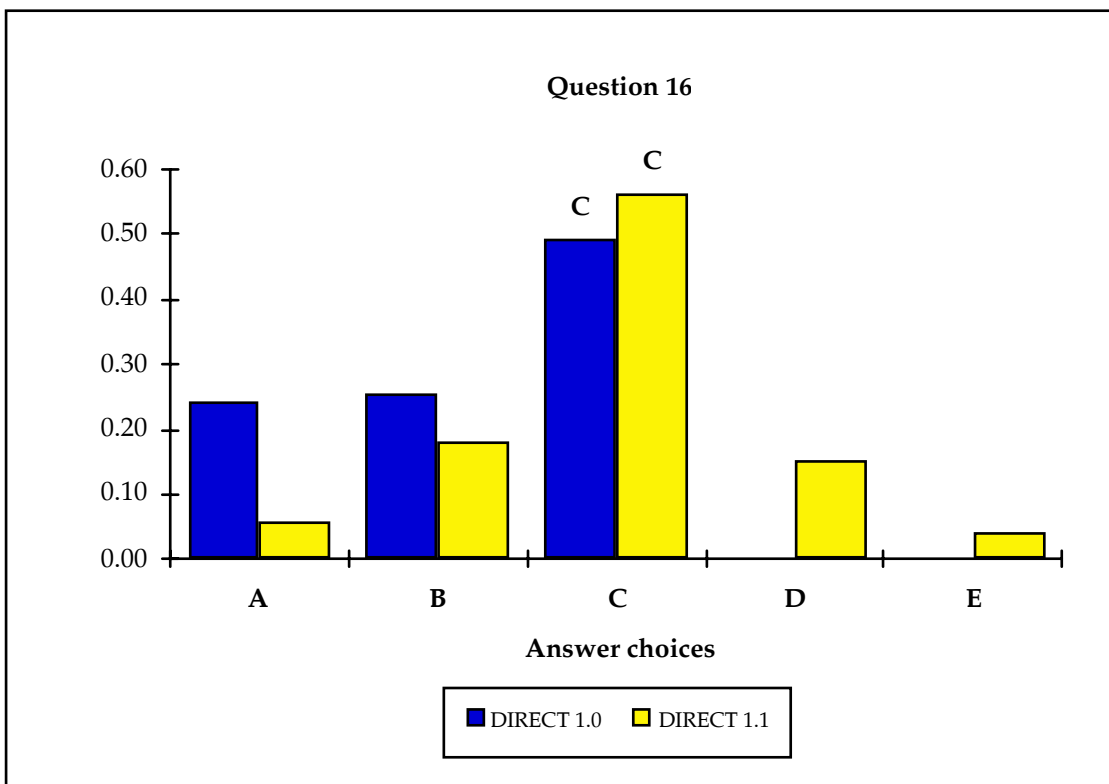
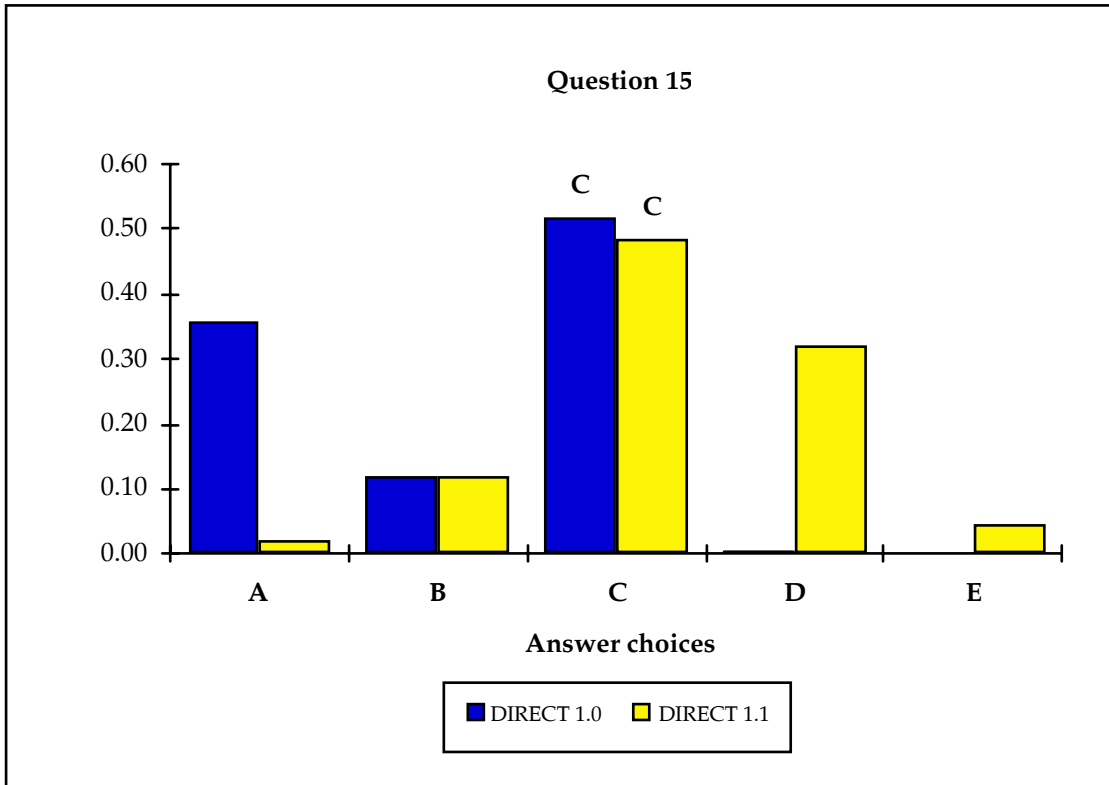

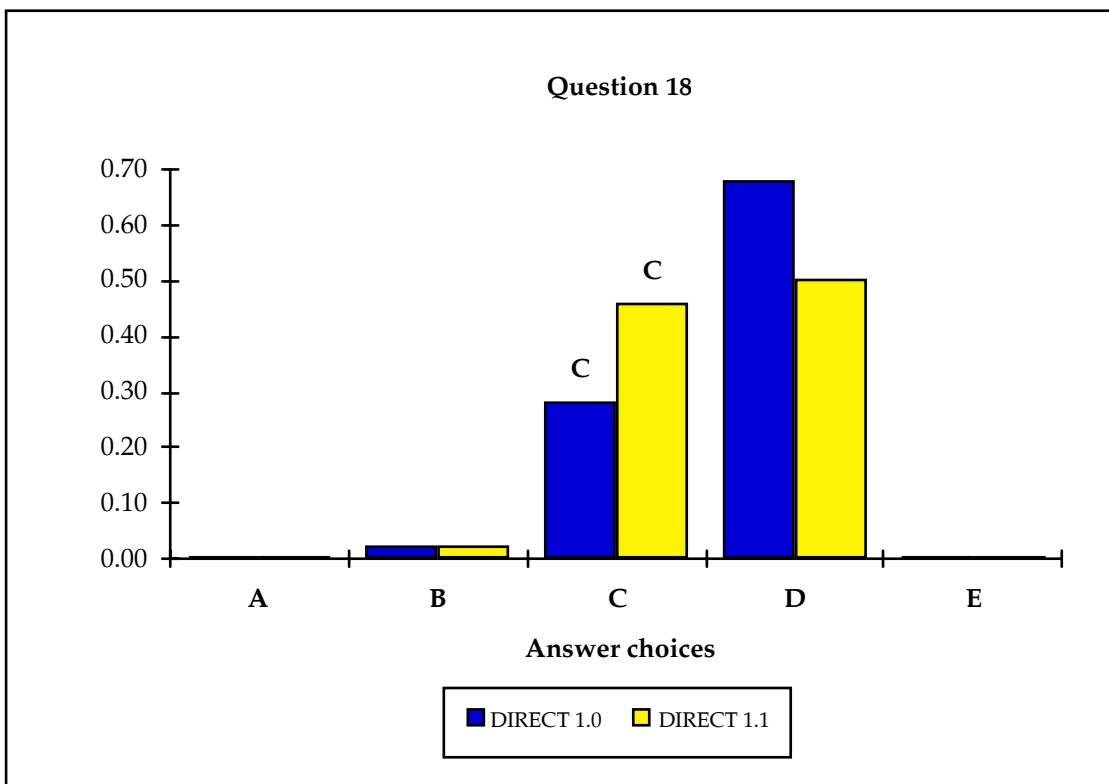
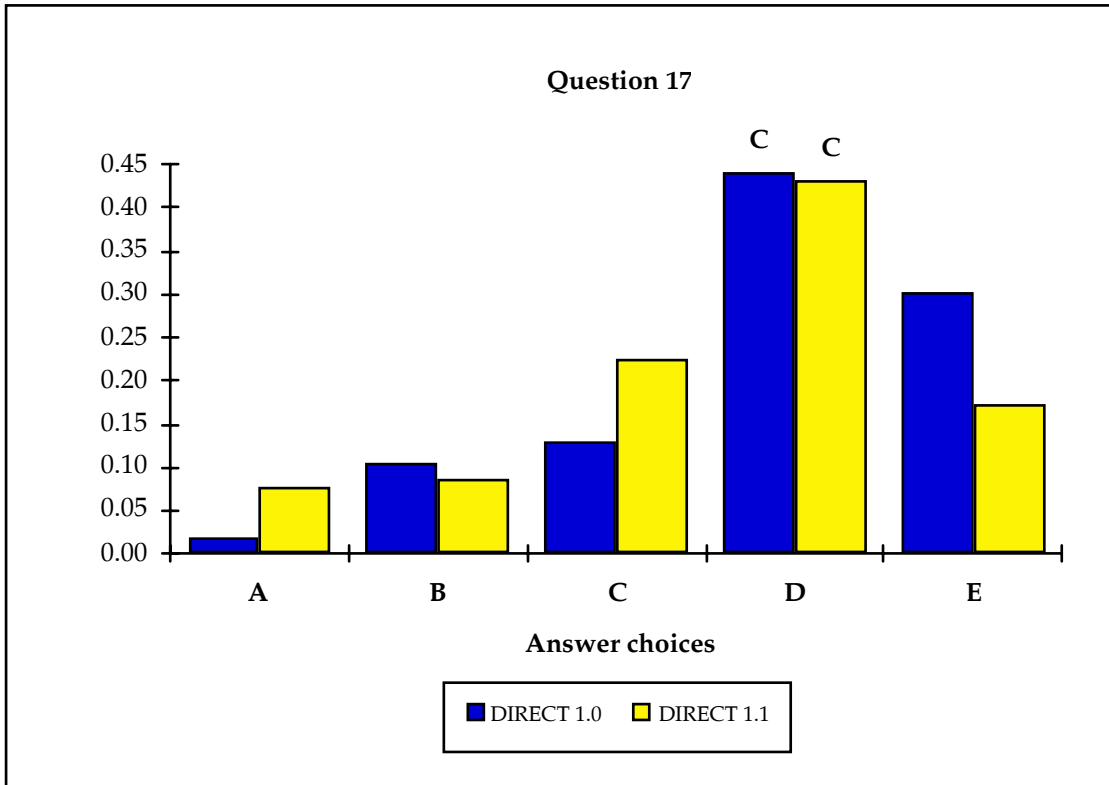

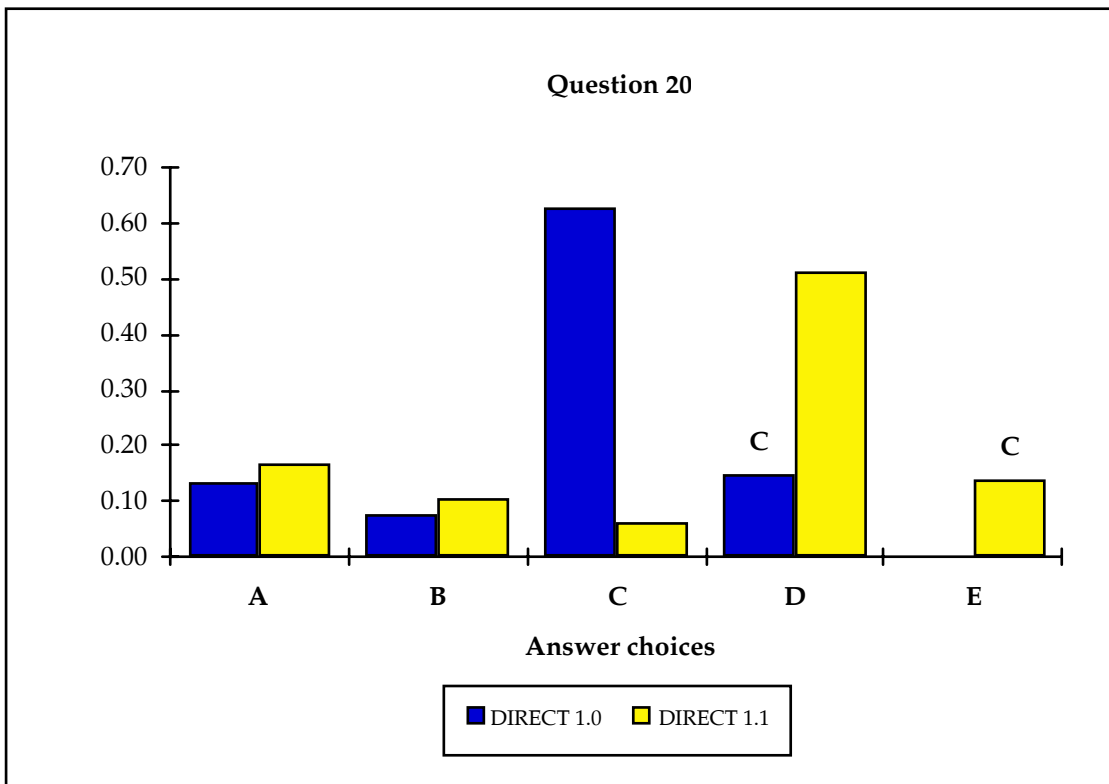
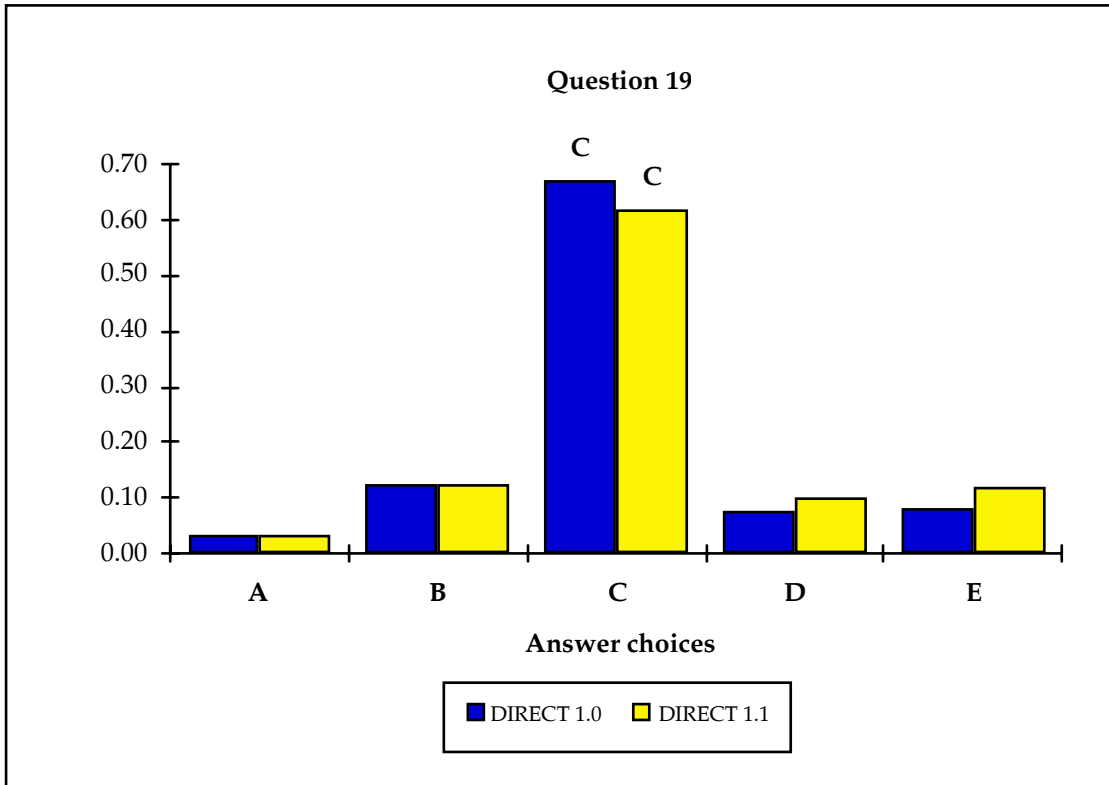

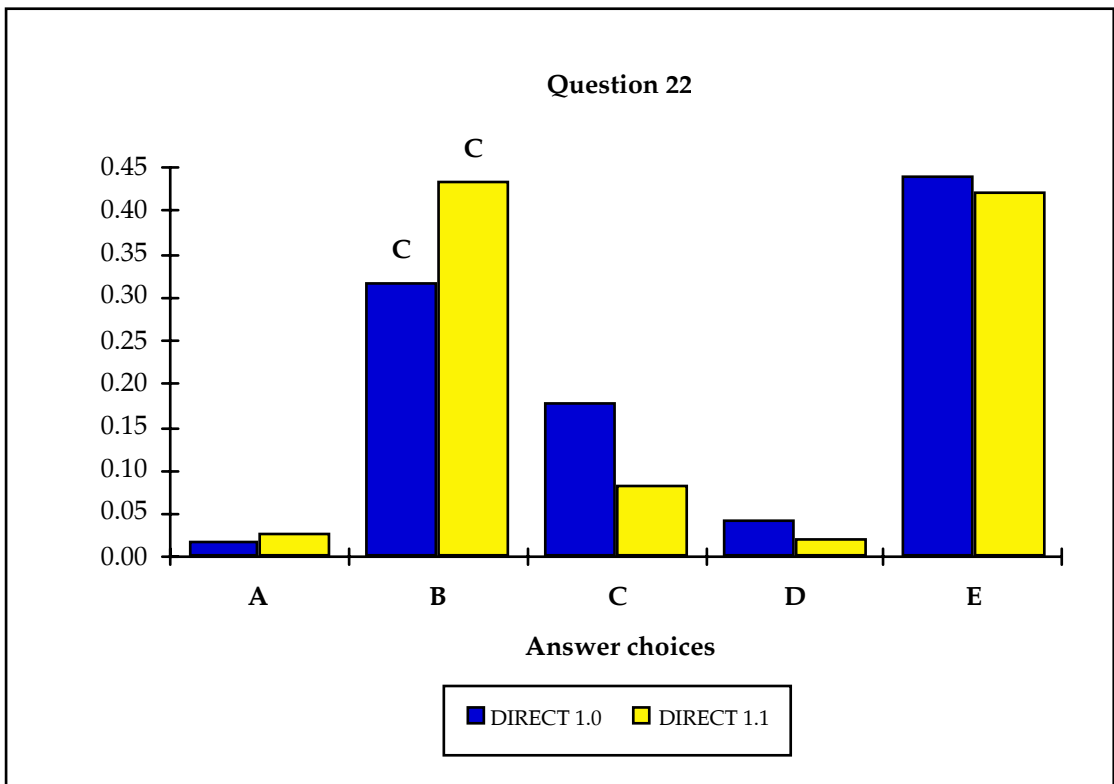
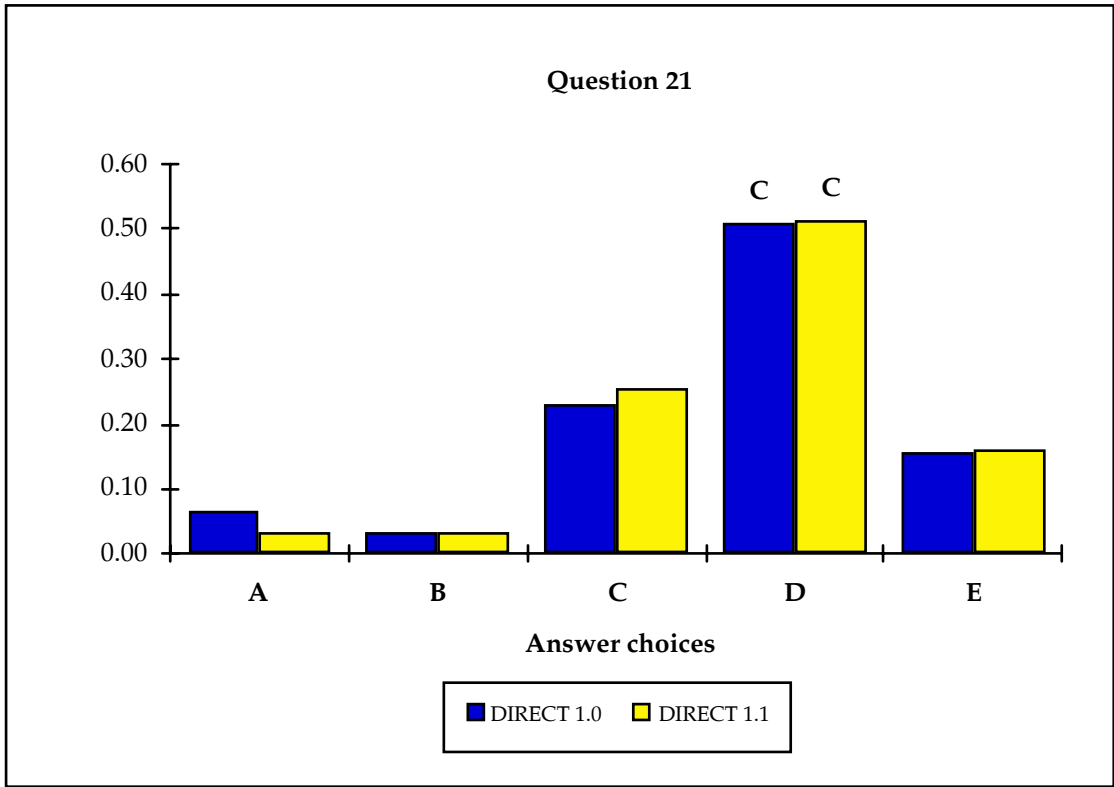

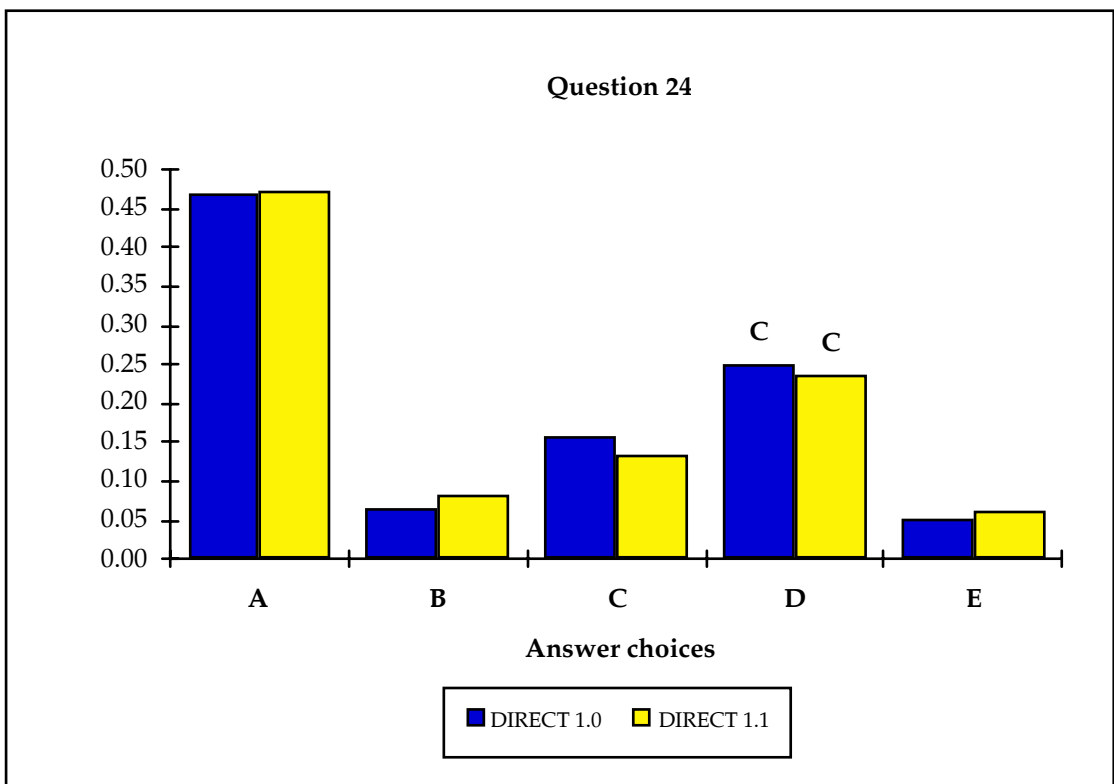
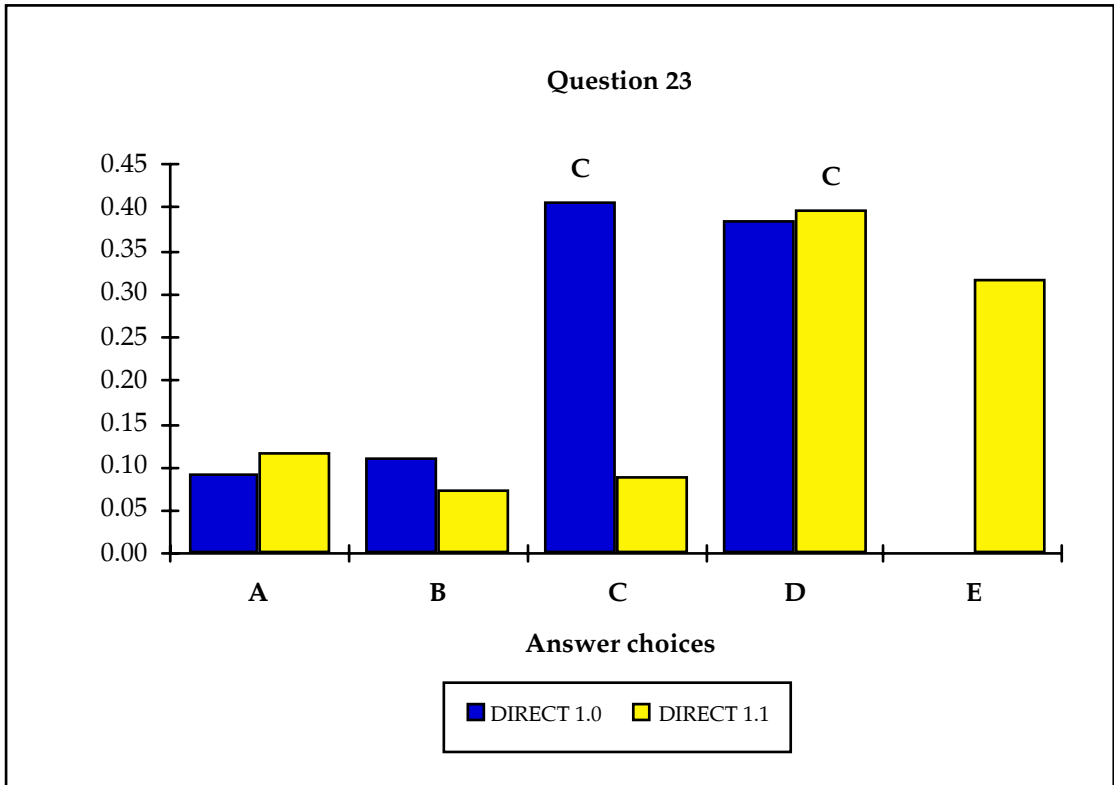

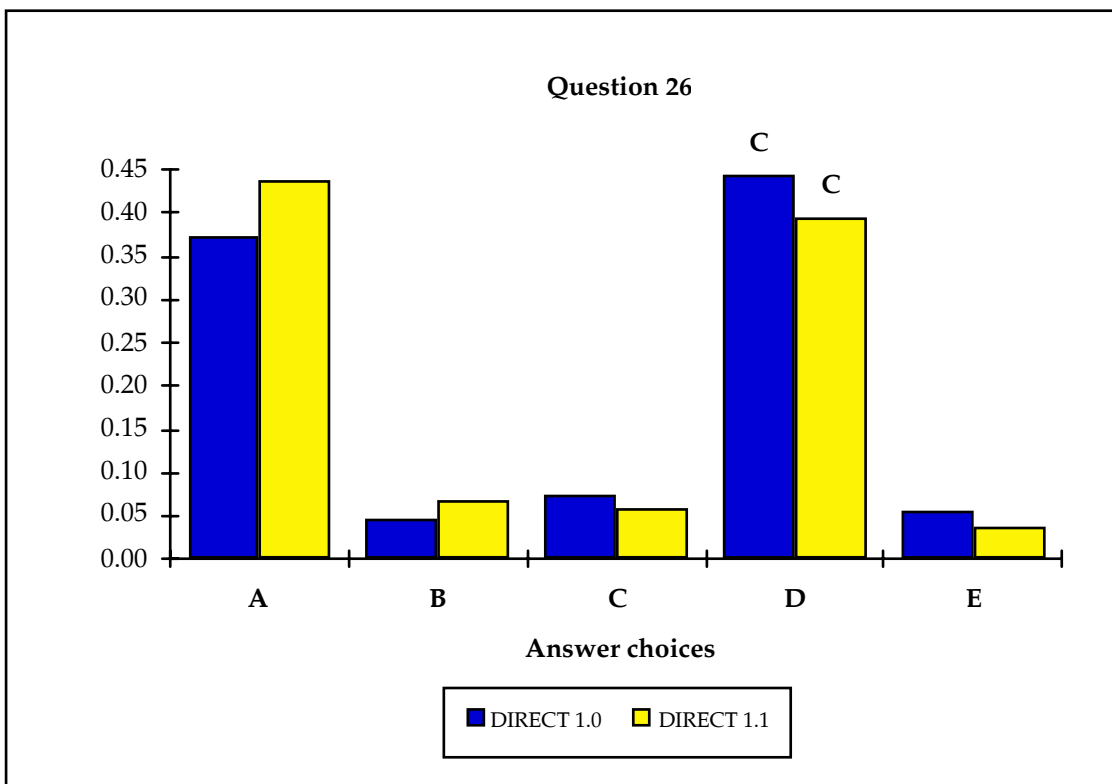
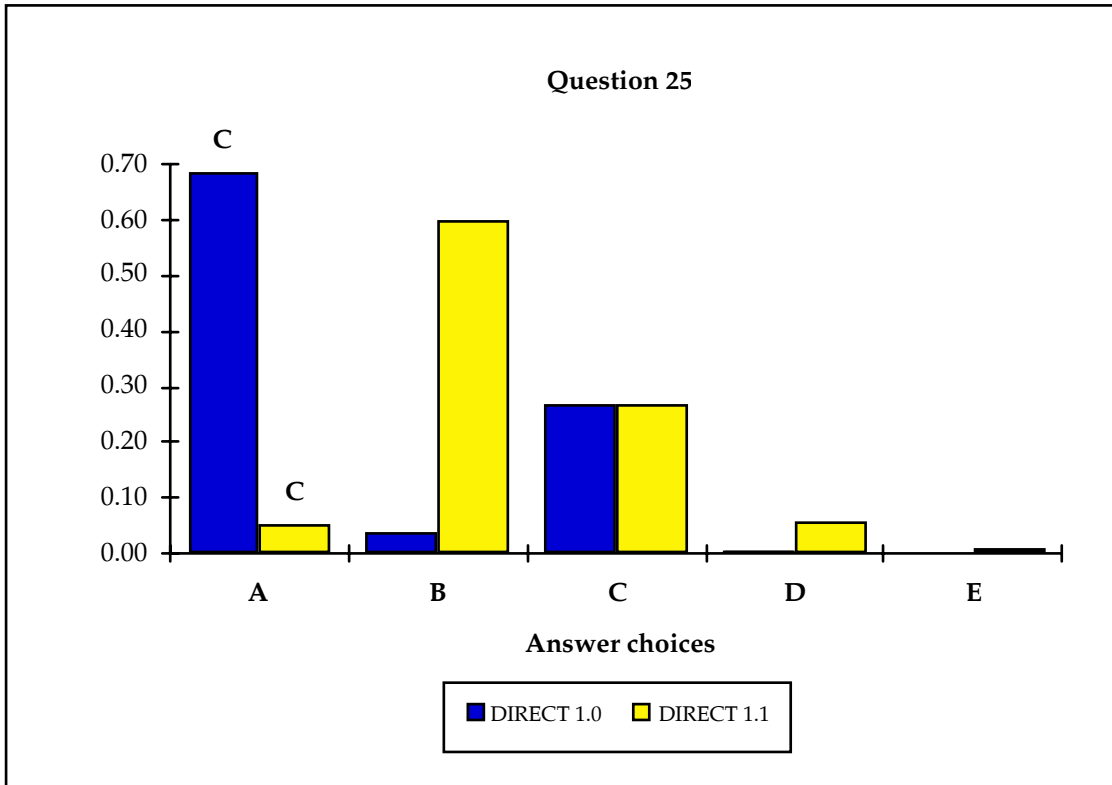

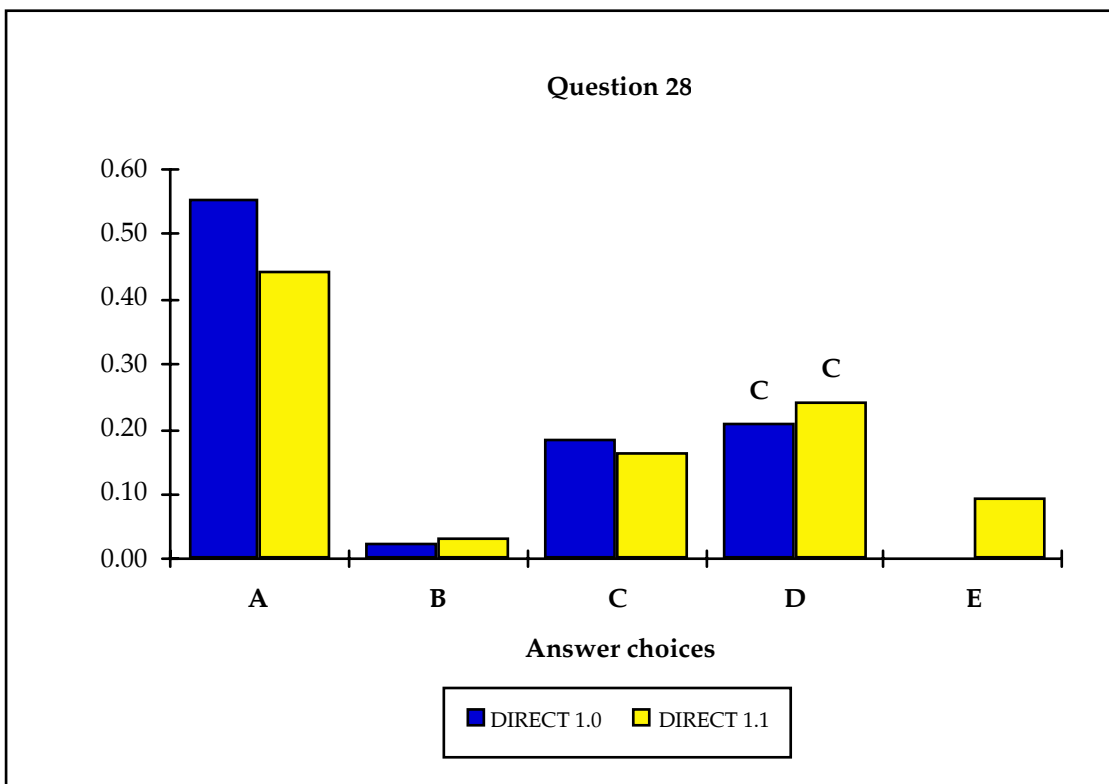
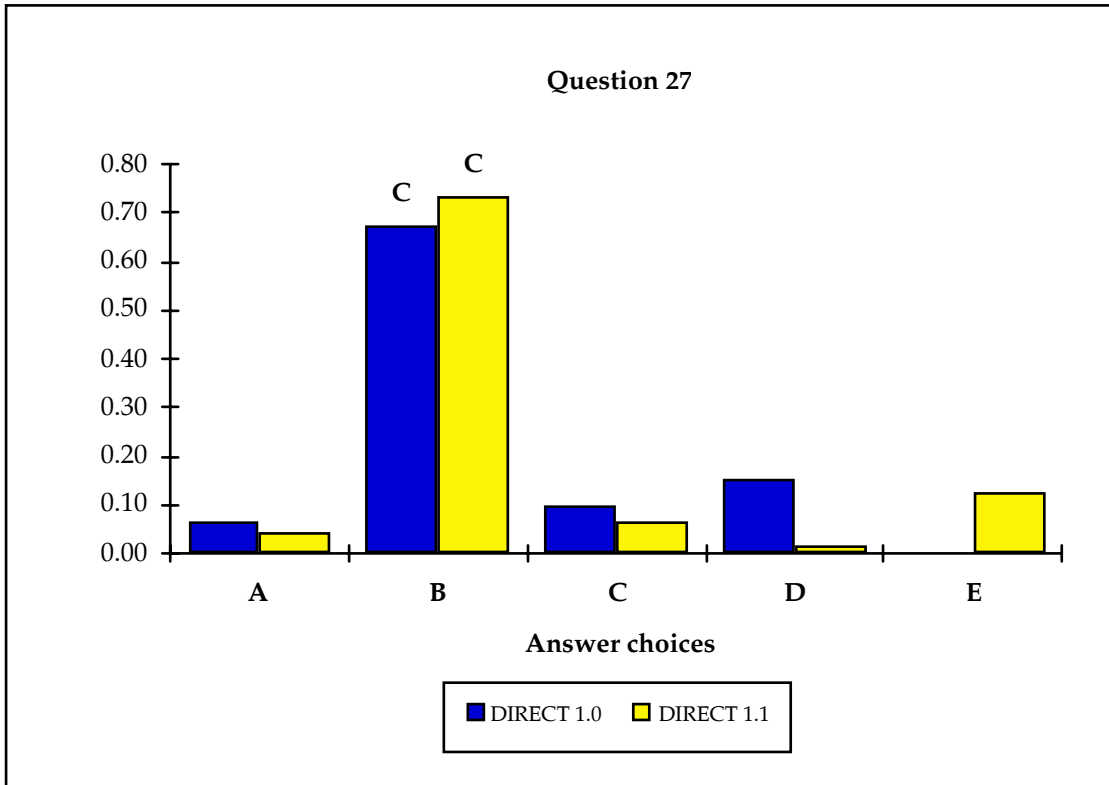

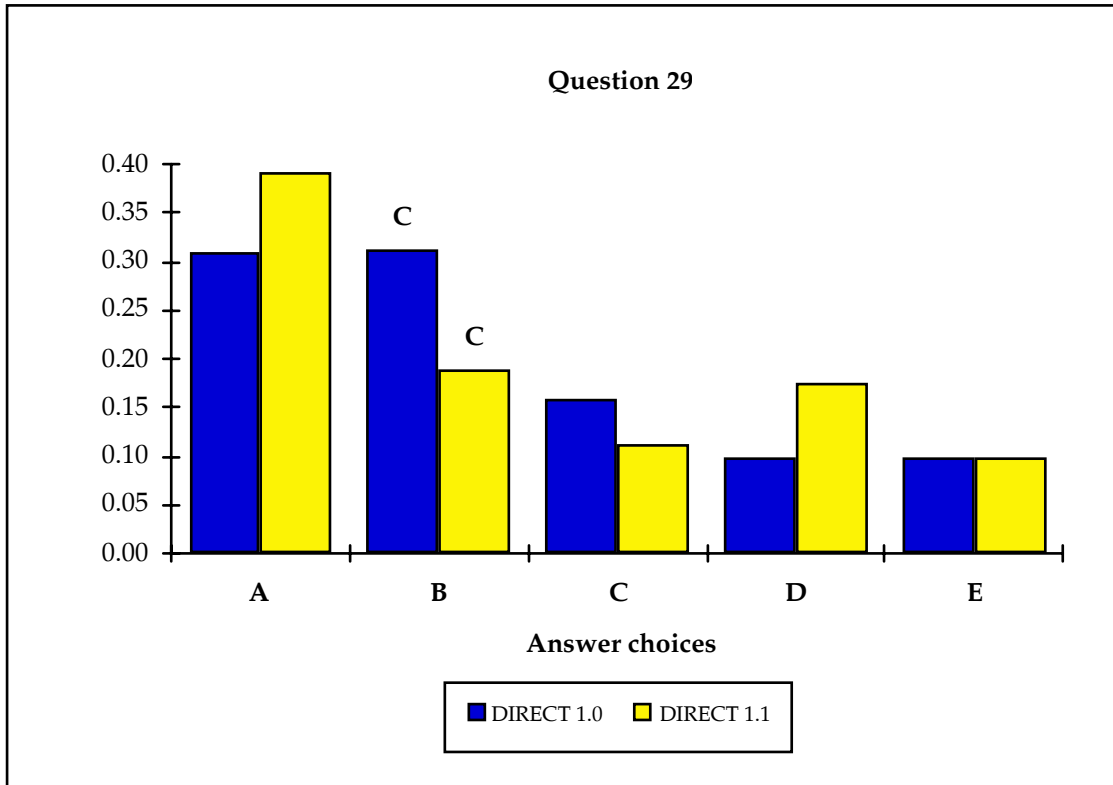

Appendix H

Misconceptions found on versions 1.0 and 1.1

See Table 4.12 for a description of each misconception

Misconception	Question on DIRECT 1.0	Average Use	Question on DIRECT 1.1	Average Use
Battery superposition	3e 12a	27	3e 7e 12a	27
Battery as a constant current source	2c 3b 7c 10c 15a 21e 25c 26a 26b 26e 29a	27	2b 2d 3b 10c 15a 16a 16e 21e 25b 25d 26a 26b 26e 29a	24
Complete circuit	9c 9e 18a 18e 27a 27c 27d 29c	6.5	9c 9e 22a 22c 22d 22e 27a 27c 27d	4.8
Contacts	9c 9e 22a 22c 22d 22e 27a 27c 27d	11	9c 9e 22a 22c 22d 22e 27a 27c 27d	9.1
Current consumed	6a 6b 8a 8b 10c 17c 21b 21c 26a 26b	18	6a 6b 8a 8b 8d 10c 17a 17c 21b 21c 26a 26b	18

Direct route	9c 9e 27a	3.3	9c 9e 27a	5.7
E=0 inside	20a	14	20a	17
I causes E	20c	63	20d	51
Local	3b 10e 29a	32	3b 10e 29a	33
R_{eq}	10d 15a	24	2b 10d 15a 25b 25d	18
Resistive superposition	5c 14a 28d 29d	18	5c 14a 29d	17
Rule application error	2a 5a 23a	25	2a 2c 5b 5d 5e 23a 23b	14
Sequential	2c 26a 26b 29a	26	26a 26b 29a	30
Term confusion I/Energy	1c	32	1d	42
Term confusion I/R	23d	39	23e	32
Term confusion I/V	6a 6b 15a 17e 24a 28a	32	6a 6b 15a 17e 24a 28a	23
Topology	4e 10c	35	4e 10c	37
$V=C_{eq}$	12c 16a 16b	21	12c 16d 16e	9.7
$V=R_{eq}$	12b 16b	21	12b 16a 16b	14

Short	4e 10a 10b 10c 10d 18b 18d 22a 22c 22d 27a 27c 27d	18	10a 10b 10c 10d 18b 18d 22a 22c 22d 22e 27c 27d 27e	15
Other	6d	15	6d	14